



CITY OF
OTTUMWA

TENATIVE AGENDA
OTTUMWA CITY COUNCIL

REGULAR MEETING NO. 17
Council Chambers, City Hall

June 20, 2023
5:30 O'Clock P.M.

PLEDGE OF ALLEGIANCE

A. ROLL CALL: Council Member Roe, Galloway, McAntire, Hull, Pope and Mayor Johnson.

B. CONSENT AGENDA:

1. Minutes from Regular Meeting No. 13 on May 16, 2023, Special Meeting No. 14 on June 2, 2023 as presented.
2. Acknowledgement of March and April financial report and payment of bills as submitted by the Finance Department.
3. Recommend appointment of James Carlson to Cemetery Board of Trustees, term to expire 7/1/28 due to a vacancy; re-appointment of Joyce Kramer to Board of Library Trustees, term to expire 7/1/29; re-appointment of John Hunolt to Cemetery Board of Trustees, term to expire 7/1/30; re-appointments of Amy Norris Hernandez, Gaylon Davis, and Nathan Wilson to Human Rights Commission, terms to expire, 7/1/26.
4. Resolution No. 96-2023, approving the updated Salary Schedule.
5. Resolution No. 97-2023, approving the Wapello County/City of Ottumwa Law Enforcement Center Maintenance Budget for Fiscal Year ending June 30, 2024.
6. Resolution No. 98-2023, authorizing destruction of certain records according to the Code of Iowa, 2017, as amended.
7. Cigarette Permit Applications for: Elliott Oil Company – Albia Road BP (1340 Albia Rd.), North Court BP (1301 N. Court St.), Pennsylvania & Jefferson BP (1147 N. Jefferson), Richmond & Ferry BP (720 Richmond Ave.), West Second BP (1049 W. Second), Casey's General Stores - #7 (1001 E. Main), #1678 (346 Richmond Ave.), #2208 (1603 W. Second), #1886 (504 W. Mary St.), Fareway Stores #648 (1325 Albia Rd.), Smokin Hot, LLC (2604 N. Court, Suite A), Walgreens #1301 (327 W. 4th St.), Dollar General #7179 (721 N. Quincy Ave.), Dollar General #2898 (921 E. Main St.), Dollar General #24713 (1235 Hutchinson Ave.), Hy-Vee #2 Fast & Fresh (2547 N. Court), Hy-Vee #2 Food Store (2453 N. Court), Hy-Vee Drugstore (1140 N. Jefferson St.), Hy-Vee #1 Food Store (1025 N. Quincy), Hy-Vee #1 Fast & Fresh (1027 N. Quincy), Walmart #1285 (1940 Venture Dr.), Smokin' Joe's Tobacco & Liquor Outlet #5 (1115 Albia Rd.), Fine Liquor & Tobacco (821 B Albia Rd.), Iowa Liquor & Tobacco (1021 E. Main St.), Murphy USA #6945 (1939 Venture Drive), Ross Tobacco Shop, LLC (129 E. Second); Yesway #1012 (2508 N. Court St.), Yesway #1013 (534 Church St.), Yesway #1014 (502 W. Second St.), Yesway #1030 (1317 E. Mary St.); MAD Ave. Quik Shop (405 S. Madison Ave.).
8. Beer and/or liquor applications for: Cobblestone Hotel & Suites and Wissota Chophouse, 108 Church Street; Jade Palace, 1404 Sherwood; Mike's Pizza & Steakhouse, 2517 Northgate St.; Yesway Store #10012, 2508 N. Court; Yesway Store #10013, 534 Church St.; Yesway Store #10030, 1317 East Mary St.; Yesway Store #10014, 502 W. Second St.; Hy-Vee Ottumwa Area Greater Ottumwa Partners in Progress, temporary outdoor service area at Jimmy Jones Shelter 7/1-7/2/2023; Uncle Buck's Bar & Grill, 518 Church St., temporary outdoor service area on 7/14/2023; Main Street Ottumwa, Dive in Move at the Beach two special 5 day events 6/29-7/3/23 and 7/27-7/31/23 at 101 Church St.; Appanoose Rapids, permanent premise transfer from 332 E.

Main to 328 E. Main, Suite 101; Appanoose Rapids, 328 E. Main, Suite 101; all applications pending final inspections.

C. APPROVAL OF AGENDA

D. ADMINISTRATORS REPORT TO COUNCIL AND CITIZENS:

All items on this agenda are subject to discussion and/or action.

E. IDENTIFICATION OF CITIZENS DESIRING TO COMMENT ON AGENDA ITEMS:

(When called upon by the Mayor, step to the microphone; state their name, address and agenda item to be addressed. The Mayor will invite you to address the Council when that topic is being discussed. Remarks will be limited to **three minutes or less**. The City Clerk shall keep the time and notify the Mayor when the allotted time limit has been reached. Comments are to be directly germane to the agenda item being discussed; if not directly germane as determined by the Mayor will be ruled out of order.)

F. PUBLIC HEARING:

1. This is the time, place and date set for a public hearing on the proposal to convey certain real property known as 1531 Mable Street, Ottumwa, Wapello County, Iowa, to Alissa Welch.
 - A. Open the public hearing.
 - B. Close the public hearing.
 - C. Resolution No. 90-2023, approving and authorizing the conveyance of certain real property known as 1531 Mable Street, Ottumwa, Iowa, to Alissa Welch for the sum of \$300.

RECOMMENDATION: Pass and adopt Resolution No. 90-2023.

G. ORDINANCES:

1. Ordinance No. 3212-2023, establishing solid waste fees for noncommercial establishments by repealing and replacing Section 31 ½ - 35 of the Municipal Code of the City of Ottumwa.

RECOMMENDATION: A. Pass the second consideration of Ordinance No. 3212-2023.
 B. Waive the third consideration, Pass and adopt Ordinance No. 3212-2023.

2. Ordinance No. 3213-2023, amending the Code of Ordinances by changing the zoning classification of property known as 526 E. Second from R-4 to C-2 in the City of Ottumwa, Wapello County, Iowa.

RECOMMENDATION: Pass the third consideration and adopt Ordinance No. 3213-2023.

3. Ordinance No. 3214-2023, amending the Code of Ordinances by changing the zoning classification of property known as 1508 Albia Road from C-1 to C-2 in the City of Ottumwa, Wapello County, Iowa.

RECOMMENDATION: Pass the third consideration and adopt Ordinance No. 3214-2023.

H. DEPARTMENTAL, BOARD, OR COMMISSION RECOMMENDATIONS/REPORTS:

1. Authorize Community Development Director to Sign Order form for Placer.AI Location Services Data Program and agree to License Agreement.

RECOMMENDATION: Authorize Community Development Director to sign order form for Placer.AI Location Services Data Program and agree to License Agreement, one-year subscription \$20,000, City's portion \$10,000 after John Deere Foundation & Greater Ottumwa Partners in Progress contributed \$10,000.

2. Purchase of Parking Lot Light Poles for the Troeger Parking Lot Project.

RECOMMENDATION: Approve the purchase of light poles and light fixtures for the Troeger Parking Lot and Bridge View Parking Lot expansion project totaling \$16,901.28.

I. RESOLUTIONS:

1. Resolution No. 92-2023, approve the Collective Bargaining Agreement with Ottumwa Police Union Teamster's Local #238, commencing on 7/1/23 – 6/30/28.

RECOMMENDATION: Pass and adopt Resolution No. 92-2023.

2. Resolution No. 93-2023, approving updates to Personnel Policy.

RECOMMENDATION: Pass and adopt Resolution No. 93-2023.

3. Resolution No. 94-2023, awarding the contract for demolition of the condemned property at 1054 & 1056 Tuttle to Environmental Edge, of Ottumwa, Iowa, in the amount of \$7,200.

RECOMMENDATION: Pass and adopt Resolution No. 94-2023.

4. Resolution No. 95-2023, awarding the contract for asbestos abatement and demolition of the condemned property at 301 N. Graves to Dan Laursen of Ottumwa, Iowa, for \$6,800 for Asbestos removal and \$18,000 for demolition total \$24,800.

RECOMMENDATION: Pass and adopt Resolution No. 95-2023.

5. Resolution No. 99-2023, approving the Final Plat of Christner's First Subdivision in the City of Ottumwa, Wapello County, Iowa.

RECOMMENDATION: Pass and adopt Resolution No. 99-2023.

6. Resolution No. 100-2023, accepting the work as final and complete and approving the final pay request for the Ottumwa Campground Shower House and Office Building Project.

RECOMMENDATION: Pass and adopt Resolution No. 100-2023.

7. Resolution No. 101-2023, approving a three-year School Resource Officer Agreement between the City of Ottumwa and the Ottumwa Community School District.

RECOMMENDATION: Pass and adopt Resolution No. 101-2023.

8. Resolution No. 102-2023, approve Change Order No. 2 for the Blake's Branch Sewer Separation Phase 8, Division 1, East of Iowa Avenue Project.

RECOMMENDATION: Pass and adopt Resolution No. 102-2023.

9. Resolution No. 103-2023, approve Iowa Department of Transportation STBG/SWAP Application for the North Court Reconstruction Project and authorize the Mayor to sign.

RECOMMENDATION: Pass and adopt Resolution No. 103-2023.

10. Resolution No. 104-2023, awarding a Five-Year Agreement to Bergan KDV, Ltd. for audit services for the City of Ottumwa (FY 23-27).

RECOMMENDATION: Pass and adopt Resolution No. 104-2023.

J. PUBLIC FORUM:

The Mayor will request comments from the public on topics of city business or operations other than those listed on this agenda. Comments shall not be personalized and limited to three minutes or less. Comments not directly applicable to operations, inappropriate, or an improper utilization of meeting time, as determined by the Mayor, will be ruled out of order. When called upon by the Mayor, step to the microphone; give your name, address and topic on which to address the Council. The Council is not likely to take any action on your comments due to requirements of the Open Meetings Law. Pertinent questions, comments or suggestions may be referred to the appropriate department, city administrator or legal counsel for response, if relevant.

K. MAYOR/CITY COUNCIL REPORT AND/OR COMMUNICATIONS

ADJOURN

***** It is the goal of the City of Ottumwa that all City Council public meetings are accessible to people with disabilities. If you need assistance in participating in City Council meetings due to a disability as defined under the ADA, please call the City Clerk's Office at (641) 683-0621 at least one (1) business day prior to the scheduled meeting to request an accommodation. *****



(CITY OF)
O T T U M W A

FAX COVER SHEET

City of Ottumwa

DATE: 6/16/2023 TIME: 10:41 AM NO. OF PAGES 5
(Including Cover Sheet)

TO: News Media CO: _____

FAX NO: _____

FROM: Christina Reinhard

FAX NO: 641-683-0613 PHONE NO: 641-683-0620

MEMO: Tentative Agenda for the Regular City Council Meeting #17 to be held on 6/20/2023 at 5:30 P.M., immediately following the Board of Health Meeting.

*** FAX MULTI TX REPORT ***

JOB NO. 3260
DEPT. ID 4717
PGS. 5
TX INCOMPLETE -----
TRANSACTION OK 916416847834
916606271885
916416823269
ERROR 916416828482

Ottumwa Courier
KTVO
Ottumwa Waterworks
Tom FM



CITY OF
OTTUMWA

FAX COVER SHEET

City of Ottumwa

DATE: 6/16/2023 TIME: 10:41 AM NO. OF PAGES 5
(Including Cover Sheet)

TO: News Media CO: _____

FAX NO: _____

FROM: Christina Reinhard

FAX NO: 641-683-0613 PHONE NO: 641-683-0620

MEMO: Tentative Agenda for the Regular City Council Meeting #17 to be held on 6/20/2023 at 5:30 P.M., immediately following the Board of Health Meeting.

*** TX REPORT ***

| | | |
|----------------|--------------|--------------------|
| JOB NO. | 3260 | |
| DEPT. ID | 4717 | |
| ST. TIME | 06/16 10:43 | |
| SHEETS | 5 | |
| FILE NAME | | |
| TX INCOMPLETE | ----- | |
| TRANSACTION OK | 916416847834 | Ottumwa Courier |
| | 916606271885 | KTVO |
| | 916416823269 | Ottumwa Waterworks |
| ERROR | 916416828482 | Tom FM |



CITY OF
OTTUMWA

FAX COVER SHEET

City of Ottumwa

DATE: 6/16/2023 TIME: 10:41 AM NO. OF PAGES 5
(Including Cover Sheet)

TO: News Media CO: _____

FAX NO: _____

FROM: Christina Reinhard

FAX NO: 641-683-0613 PHONE NO: 641-683-0620

MEMO: Tentative Agenda for the Regular City Council Meeting #17 to be held on 6/20/2023 at 5:30 P.M., immediately following the Board of Health Meeting.

OTTUMWA CITY COUNCIL MINUTES

REGULAR MEETING NO. 13
Council Chambers, City Hall

May 16, 2023
5:30 O'Clock P.M.

The meeting was called to order at 5:30 P.M.

Present were Council Member Galloway, McAntire, Hull, Pope, Roe and Mayor Johnson.

Roe moved, seconded by Galloway to approve consent agenda items: Mins. from Regular Mtg. No. 11 on May 2, 2023 and Special Mtg. No. 12 on May 9, 2023 as presented; Historic Preservation Month Proclamation; Foster Care Month Proclamation; Res. No. 67-2023, approving contract, bonds and cert. of ins. for Green St. Sewer Improv. Project – Group A; Res. No. 80-2023, approving contract, bonds and cert. of ins. for Ottumwa Campground Parking Lot & RV Dump Station Project; Res. No. 84-2023, approving lease agt. with Ottumwa Saddle Club; Res. No. 89-2023, fixing date for public hearing on disposition of City owned property at 1531 Mable St.; Res. No. 91-2023, approving three-yr. lease agt. with Ottumwa Comm. School Dist. for use of the Beach Ottumwa facilities; Beer and/or liquor applications for: Applebee's, 1303 Vaughn Dr.; all applications pending final inspections. All ayes.

McAntire moved, seconded by Roe to approve agenda as presented. All ayes.

City Admin. Rath provided an update on Gallagher Wage Study; goal is completion of study by end of May; city council mtgs. are open to the public and we encourage all to attend, but do want to remind everyone that council operates under a set of rules to keep mtgs. running smoothly and an efficient use of everyone's time.

Mayor Johnson inquired if anyone from the audience wished to address an item on the agenda. Josh Kirby requested to speak about Item G-2.

This was the time, place and date set for public hearing to adopt Amendment No. 3 to *Our Ottumwa 2040* Comprehensive Plan and providing Plan Updates. Comm. Dev. Dir. Simonson reported this amendment extends Zoning Districts which are partially compatible with neighborhood mixed-use and public/semi-public/institutional land use categories in the Zoning Compatibility Matrix of the Future Land Use Plan. No objections rec'd. Galloway moved, seconded by McAntire to close public hearing. All ayes.

Hull moved, seconded by Roe that Res. No. 87-2023, adopting Amendment No. 3 to *Our Ottumwa 2040* Comprehensive Plan and providing Plan Updates, be passed and adopted. All ayes.

This was the time, place and date set for a public hearing on proposed Ord. No. 3212-2023, est. solid waste fees for noncommercial establishments by repealing and replacing Section 31 ½ - 35 of the Muni Code of the City of Ottumwa. Simonson reported current rate structure exp. July 1, 2023; new fees include an increase of \$2.82 per month (or 14.7%). This increase accounts for the increase in landfill tipping fee, contract increase for Bridge City Sanitation, fuel surcharge paid to Bridge City Sanitation and admin. costs. This increase will show on citizens water bills. No objections rec'd. Pope moved, seconded by Galloway to close public hearing. All ayes.

McAntire moved, seconded by Pope to pass first consideration of Ord. No. 3212-2023, est. solid waste fees for noncommercial establishments by repealing and replacing Section 31 ½ - 35 of the Muni. Code of the City of Ottumwa. All ayes.

Roe moved, seconded by Galloway to pass second consideration of Ord. No. 3213-2023, amending Muni. Code of City of Ottumwa by changing zoning classification of property 526 E. Second from R-4 to C-2 in the City of Ottumwa, Wapello County, IA. All ayes.

Pope moved, seconded by Hull to pass second consideration of Ord. No. 3214-2023, amending Muni. Code of City of Ottumwa by changing zoning classification of property 1508 Albia Rd. from C-1 to C-2 in the City of Ottumwa, Wapello County, IA. Mr. Kirby was also available for any questions. Motion carried 4-1. Ayes: Galloway, McAntire, Hull, Pope. Nays: Roe.

Hull moved, seconded by McAntire to approve submission of grant application to Bureau of Justice Assistance to participate in 2023 Bulletproof Vest Partnership Program, and auth. Mayor or Chief of Police to sign any related docs. Lt. Hucks was available for any questions. All ayes.

Roe moved, seconded by McAntire to auth. Finance Dir. to proceed with issuing Request for Proposals (RFP) regarding general audit services for City of Ottumwa. Finance Dir. Nisar reported our current provider, Anderson Larkin, gave notice to the City on March 31 that they would no longer be able to provide said services. They provided a few firms to reach out to, but none are local, but still in IA. RFP would solicit services for the next five yrs (FY27/28). Roe asked about a timeline as we are coming up on FY23 End in the next month and Nisar feels we can do this fairly quickly. All ayes.

Hull moved, seconded by Roe that Res. No. 69-2023, approving CO No. 1 through No. 4 and accepting work as final and complete for replacement of the City's Phone System through Marco Technologies, LLC, be passed and adopted. Rath reported original contract amt. was \$122,933.64 and budgeted out of Capital Projects Fund. With all CO factored, new contract sum \$130,741.73. All ayes.

Pope moved, seconded by McAntire that Res. No. 81-2023, approving CO No. 3 and accepting work as final and complete and approving final pay request for Milner St. Reconstruction Project, be passed and adopted. PW Dir. Seals reported CO No. 3 decreases contract by \$117,342.47 for qty. adj.; new contract sum \$2,396,206.35. All ayes.

McAntire moved, seconded by Galloway that Res. No. 82-2023, approving Amendment to Design Contract between City and Willett Hofmann & Assoc. for City Hall Improv. Project, be passed and adopted. Seals reported bids rec'd for original scope were rejected due to cost over engineer's est. Discussed updating scope to reflect a few changes and rebid. Major scope changes proposed are to remove full remodel of restrooms on 2nd and 3rd floors; reduce the number of heating and cooling zones from twelve to eight; use force account for lighting improvement in basement, second and third floors; reduce construction phasing for first floor construction by relocating employees; selecting material alternatives. Original base contract \$275,750; amendment increases contract \$22,000; new contract sum \$297,750. All ayes.

Hull moved, seconded by Roe that Res. No. 83-2023, approving submission of application for IA Airport Capital Improv. Program (ACIP) and Certifying Elig. Requirements for fiscal yrs. 2024-2028, be passed and adopted. Dir. of Airport Operations Wheaton reported annual plan is submitted to IA DOT that normally secures 85% funding with 15% local match. All ayes.

Galloway moved, seconded by McAntire that Res. No. 85-2023, setting fee for annual permits for trash enclosures in City parking lots, be passed and adopted. Seals reported Ord. No. 3184-2021 amended City Code to allow privately owned or leased trash dumpsters or receptacles in City parking lots. Recommended that annual fee be set at \$300 per year due in January. Permit application and fee shall be submitted to City Clerk's office. All ayes.

Roe moved, seconded by McAntire that Res. No. 88-2023, approving and auth. execution of a Consent to Assignment of an Agt. for Private Development from Asbury Mgr., LLC to Asbury Heights, LLC, be passed and adopted. Simonson reported on April 18, 2023, City entered DA for construction of 30 units of affordable housing on two sites (Asbury & Sherwood). The agt. was with Asbury Mgr., LLC. Financing of project requires assignment of agt. to a separate entity, Asbury Heights, LLC. This assignment does not change any terms of agt. or expected deliverables. All ayes.

Mayor Johnson inquired if anyone from the audience wished to address an item not on the agenda. There were none.

There being no further business, Galloway moved, seconded by Pope that the mtg. adjourn. All ayes.

Adjournment was at 6:30 P.M.

CITY OF OTTUMWA, IOWA

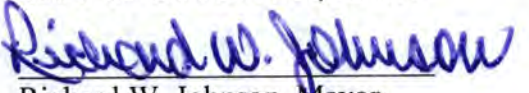
Richard W. Johnson, Mayor

ATTEST:

Christina Reinhard, CMC, City Clerk

Published in the Ottumwa Courier on May 27, 2023.

OTTUMWA CITY COUNCIL MINUTES

SPECIAL MEETING NO. 14
Room 108, 105 E. Third St.

June 2, 2023
3:30 O'Clock P.M.

The meeting was called to order at 3:30 P.M.

Present were Council Member Roe & Galloway. Hull & Pope via telephone conference.
Council Member McAntire was absent.
Mayor Johnson was absent. Council Member Roe acted as Mayor Pro Tem.

Pope moved, seconded by Hull to approve the agenda as presented. Motion carried 3-2. Absent: McAntire. Roe did not vote.

Mayor Pro Tem Roe inquired if there was anyone from the audience who wished to address an item on the agenda. There were none.

Hull moved, seconded by Pope to approve Beer and/or Liquor application for a 1 day Special Event on 6/3/23 for Parkview Plaza, Ltd. Dba Hotel Ottumwa. Motion carried 3-2. Absent: McAntire. Roe did not vote.

There being no further business, Galloway moved, seconded by Pope that the mtg. adjourn. Motion carried 3-2. Absent: McAntire. Roe did not vote.

Adjournment was at 3:32 P.M.

CITY OF OTTUMWA, IOWA

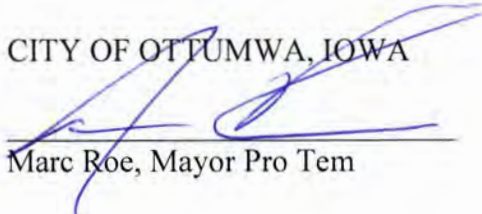

Marc Roe, Mayor Pro Tem

ATTEST:

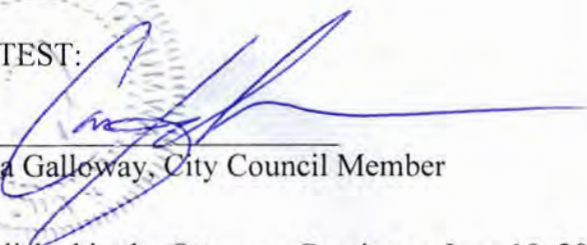

Cara Galloway, City Council Member

Published in the Ottumwa Courier on June 10, 2023.

**CITY OF OTTUMWA
STATEMENT OF CHANGES IN CASH BALANCE
MARCH, 2023**

| ACCOUNT NUMBER | ACCOUNT DESCRIPTION | BEG. PERIOD | | CASH | |
|---------------------|---------------------|-----------------|----|---------------|-----------------|
| | | BALANCE | | DEBITS | CREDITS |
| TOTALS FOR FUND 001 | GENERAL OPER | \$ (97,808.24) | \$ | \$ 930,488.66 | \$ 1,524,511.96 |
| TOTALS FOR FUND 002 | PARKING RAMP | \$ 53,937.02 | \$ | \$ 1,871.15 | \$ 1,508.01 |
| TOTALS FOR FUND 003 | GENERAL-ARPA | \$ 3,081,458.10 | | | |
| TOTALS FOR FUND 110 | ROAD USE TAX | \$ 4,828,188.67 | \$ | \$ 743,106.41 | \$ 415,844.37 |
| TOTALS FOR FUND 112 | EMPLOYEE BEN | \$ 4,554,241.40 | \$ | \$ 151,452.88 | |
| TOTALS FOR FUND 119 | EMERGENCY FU | \$ 108,972.43 | \$ | \$ 5,525.27 | |
| TOTALS FOR FUND 121 | SALES TAX 1% | \$ 9,166,682.58 | \$ | \$ 350,908.42 | |
| TOTALS FOR FUND 122 | ***** | | | | |
| TOTALS FOR FUND 123 | AGASSI TIF D | | | | |
| TOTALS FOR FUND 124 | VOGEL URBAN | | | | |
| TOTALS FOR FUND 125 | WESTGATE TIF | \$ (129,147.08) | \$ | \$ 62,164.76 | \$ 600.00 |
| TOTALS FOR FUND 126 | AIRPORT TIF | \$ 147,301.69 | \$ | \$ 3,978.48 | |
| TOTALS FOR FUND 127 | PENNSYLVANIA | | | | |
| TOTALS FOR FUND 128 | WILDWOOD HWY | \$ 92,803.29 | | | |
| TOTALS FOR FUND 129 | RISK MANAGEM | \$ 660,977.33 | \$ | \$ 15,349.79 | \$ 741,345.19 |
| TOTALS FOR FUND 131 | AIRPORT FUND | \$ (68,746.04) | \$ | \$ 424,891.45 | \$ 120,256.78 |
| TOTALS FOR FUND 133 | LIBRARY FUND | \$ (29,051.85) | \$ | \$ 6,581.23 | \$ 95,778.37 |
| TOTALS FOR FUND 135 | CEMETERY FUN | \$ (129,651.13) | \$ | \$ 8,612.00 | \$ 29,387.94 |
| TOTALS FOR FUND 137 | HAZ-MAT FUND | \$ 151,573.23 | \$ | \$ 1,571.06 | \$ 16,263.72 |
| TOTALS FOR FUND 141 | 2023 UPPER S | \$ 192,938.79 | | | \$ 193,223.58 |
| TOTALS FOR FUND 142 | HOAP/HILP ES | | | | |
| TOTALS FOR FUND 143 | EPA BROWNFIE | | | | |
| TOTALS FOR FUND 144 | 2013 CDBG HO | | | | |
| TOTALS FOR FUND 145 | DOWNTOWN REV | | | | |
| TOTALS FOR FUND 146 | DOWNTOWN STR | \$ 142,220.06 | | | |
| TOTALS FOR FUND 147 | CDBG P-2 MAS | \$ 17,628.32 | | | |
| TOTALS FOR FUND 148 | 2016 OWW CDB | | | | |
| TOTALS FOR FUND 151 | OTHER BOND P | \$ 2,267,545.16 | \$ | \$ 92,222.00 | \$ 159,932.40 |
| TOTALS FOR FUND 162 | SSMID DISTRI | \$ 76,801.90 | \$ | \$ 407.39 | \$ 7,885.85 |
| TOTALS FOR FUND 167 | FIRE BEQUEST | \$ 14,032.30 | | | |
| TOTALS FOR FUND 169 | START UP/DON | \$ (165.20) | | | |
| TOTALS FOR FUND 171 | RETIREE HEAL | \$ (1,698.17) | | | |
| TOTALS FOR FUND 173 | LIBRARY BEQU | \$ 91,292.89 | \$ | \$ 2,150.00 | \$ 8,030.34 |
| TOTALS FOR FUND 174 | COMMUNITY DE | \$ 428,616.15 | \$ | \$ 37.00 | |
| TOTALS FOR FUND 175 | POLICE BEQUE | \$ 174,485.84 | \$ | \$ 3,851.67 | \$ 4,244.90 |
| TOTALS FOR FUND 176 | Reimb Grants | | \$ | \$ 1,802.00 | \$ 26,007.27 |
| TOTALS FOR FUND 177 | HISTORIC PRE | \$ 26,446.09 | | | |
| TOTALS FOR FUND 200 | DEBT SERVICE | \$ 2,141,505.31 | \$ | \$ 95,606.99 | |
| TOTALS FOR FUND 301 | STREET PROJE | \$ 1,680,727.27 | | | \$ 46,801.28 |
| TOTALS FOR FUND 303 | AIRPORT PROJ | \$ 358,702.56 | | | |
| TOTALS FOR FUND 307 | SIDEWALK & C | \$ 175,291.69 | | | \$ 50,378.46 |
| TOTALS FOR FUND 309 | PARK PROJECT | \$ 1,186,541.83 | | | \$ 2,687.91 |
| TOTALS FOR FUND 311 | LEVEE PROJEC | \$ (157,865.13) | | | \$ 2,416.73 |
| TOTALS FOR FUND 313 | EVENT CENTER | \$ 1,278,983.51 | | | \$ 2,838.74 |
| TOTALS FOR FUND 315 | SEWER CONSTR | \$ 3,777,901.48 | | | \$ 455,185.33 |
| TOTALS FOR FUND 320 | WEST END FLO | | | | |
| TOTALS FOR FUND 501 | CEMETERY MEM | \$ 2,713.29 | | | |
| TOTALS FOR FUND 503 | CEMETERY PER | \$ 201.00 | \$ | \$ 490.00 | \$ 165.00 |
| TOTALS FOR FUND 610 | SEWER UTILIT | \$ 3,348,649.98 | \$ | \$ 853,457.12 | \$ 462,857.37 |

| | | | | | | | | |
|-----------------|-----|---------------|-----------|----------------------|-----------|---------------------|-----------|---------------------|
| TOTALS FOR FUND | 611 | SEWER SINKIN | \$ | 1,377,000.00 | | | | |
| TOTALS FOR FUND | 612 | STORM WATER | | | | | | |
| TOTALS FOR FUND | 613 | SEWER IMPROV | \$ | 4,050,000.00 | | | | |
| TOTALS FOR FUND | 670 | LANDFILL FUN | \$ | 1,826,308.41 | \$ | 211,190.30 | \$ | 321,692.50 |
| TOTALS FOR FUND | 671 | LANDFILL RES | \$ | 1,191,555.00 | | | | |
| TOTALS FOR FUND | 673 | RECYCLING | \$ | 526,964.98 | \$ | 205,658.10 | \$ | 66,498.93 |
| TOTALS FOR FUND | 690 | TRANSIT FUND | \$ | 633,754.93 | | | \$ | 107.71 |
| TOTALS FOR FUND | 695 | 1015 TRANSIT | | | | | | |
| TOTALS FOR FUND | 720 | BRIDGEVIEW E | \$ | (174,598.26) | | | \$ | 91,955.90 |
| TOTALS FOR FUND | 750 | GOLF COURSE | \$ | 40,748.62 | | | | |
| TOTALS FOR FUND | 810 | POOLED INVES | \$ | (47,745,799.70) | \$ | 17,265.77 | | |
| TOTALS FOR FUND | 820 | PAYROLL CLEA | \$ | 513,111.93 | \$ | 606,814.11 | \$ | 409,136.29 |
| TOTALS FOR FUND | 840 | EQUIPMENT PU | \$ | 2,912,292.31 | \$ | 25,270.00 | \$ | 31,205.75 |
| TOTALS FOR FUND | 860 | GROUP HEALTH | \$ | 6,171,286.53 | \$ | 158,314.50 | \$ | 385,411.75 |
| TOTALS FOR FUND | 861 | POST 65 RETI | \$ | 285,942.00 | \$ | 2,430.80 | \$ | 28,047.02 |
| TOTALS FOR FUND | 862 | DENTAL INSUR | \$ | 60,543.43 | \$ | 7,743.00 | \$ | 7,685.92 |
| TOTALS FOR FUND | 863 | LIFE INSURAN | \$ | 41,801.28 | \$ | 4,347.93 | \$ | 4,412.93 |
| | | TOTALS | \$ | 11,326,139.78 | \$ | 4,995,560.24 | \$ | 5,714,306.20 |

City of Ottumwa
Vender Payment Report
March, 2023

| Vendor # | Vendor Name | Check # Number | Check Date | Amount | Reason |
|----------|---------------------------|-------------------|------------|-----------|---------------------------|
| 690 | AFLAC | 217233 | 3/10/2023 | 2026.08 | AFLAC DEDUCTION PAYABL |
| 800 | AHLERS & COONEY P.C. | 217184 | 3/3/2023 | 11737.62 | CONTRACTUAL SERVICES |
| 1700 | ALLIANT ENERGY/IPL | 217234 | 3/10/2023 | 69640.46 | ELECTRIC |
| 2080 | ALTORFER INC. | 217185 | 3/3/2023 | 2660.24 | VHCL MTCE SUPPLIES |
| 2592 | AMERICAN BOTTLING COMPANY | 217236 | 3/10/2023 | 150.57 | CONCESSION - RESALE |
| 4995 | APWA | 217306 | 3/17/2023 | 764.00 | DUES & MEMBERSHIPS |
| 5368 | AREA 15 REGIONAL PLANNING | 217237 | 3/10/2023 | 1627.78 | CONTRACTUAL SERVICES |
| 5586 | MIKE ASHLOCK | 217307 | 3/17/2023 | 176.54 | SUSTENANCE SUPPLIES |
| 5694 | AUTOMATIC SYSTEMS CO. | 217406 | 3/31/2023 | 3140.00 | OTHER MAINT & REPAIR |
| 5700 | ATOMIC TERMITE & PEST | 217238 | 3/10/2023 | 195.00 | FOUNDNS MAINT & REPAIR |
| 5860 | AUTOZONE INC | 217408 | 3/31/2023 | 673.14 | MISCELLANEOUS |
| 5862 | AVFUEL CORP | 217409 | 3/31/2023 | 24328.51 | AVIATION FUEL |
| 6481 | BAILEY OFFICE OUTFITTERS | 217186 | 3/3/2023 | 536.98 | OFFICE SUPPLIES |
| 7019 | BRADLEY T BARNES | 217239 | 3/10/2023 | 1207.50 | OTHER PROF SERV |
| 7642 | BEAR CREEK ARCHEOLOGY INC | 217187 | 3/3/2023 | 3974.26 | MISCELLANEOUS |
| 7873 | JASON BELL | 217367 | 3/24/2023 | 119.55 | TRAVEL & CONFERENCE |
| 9352 | BLACKSTONE PUBLISHING | 217240 | 3/10/2023 | 179.98 | LIBRARY MAT-GRUBB ESTA |
| 9360 | BLACK'S TIRE COMPANY LLC | 217188 | 3/3/2023 | 22.50 | VHCL MTCE SUPPLIES |
| 9393 | BLESSING SOUP KITCHEN | 217241 | 3/10/2023 | 26007.27 | Reimb Grants Expenditures |
| 9680 | GEORGE BOITNOTT | 217309 | 3/17/2023 | 162.00 | OPERATING SUPPLIES |
| 9693 | BECKY BOLIN | 217368 | 3/24/2023 | 144.58 | SUSTENANCE SUPPLIES |
| 11496 | BRIDGE CITY SANITATION LL | 217310 | 3/17/2023 | 157982.79 | OTHER PROF SERV |
| 11506 | BRIDGE VIEW CENTER | 217242 | 3/10/2023 | 92157.69 | MANAGEMENT SERVICES |
| 12500 | BUB'S TREE CARE | 217370 | 3/24/2023 | 7975.00 | MISCELLANEOUS |
| 13646 | CALHOUN-BURNS & ASSOC INC | 217244 | 3/10/2023 | 822.00 | ENGINEERING |
| 14317 | CAPITAL ONE | 217190 | 3/3/2023 | 1511.75 | VHCL MTCE SUPPLIES |
| 14318A | CAPITAL CITY EQUIPMENT CO | 217245 | 3/10/2023 | 816.60 | VHCL MTCE SUPPLIES |
| 14320 | CAPITAL SANITARY SUPPLY | 217414 | 3/31/2023 | 369.66 | OPERATING SUPPLIES |
| 15788 | CATERPILLAR GLOBAL SERVIC | 217313 | 3/17/2023 | 2917.80 | VHCL MTCE SUPPLIES |
| 16300 | CENTRAL IOWA FASTENERS | 217192 | 3/3/2023 | 320.41 | MISCELLANEOUS |
| 16312 | CENTRAL SALT LLC | 217246 | 3/10/2023 | 21626.84 | STREET MAINT SUPPLIES |
| 16402 | CENTURYLINK | 217372 | 3/24/2023 | 1647.69 | TELEPHONE/IT |
| 16403 | CENTURYLINK | 217316 | 3/17/2023 | 6.70 | TELEPHONE/IT |
| 17035 | CHICKERING FOUNDATION INC | 217194 | 3/3/2023 | 5460.00 | STREET MAINT |
| 17500 | CHRISTNER CONTRACTING INC | 217248 | 3/10/2023 | 16431.72 | CONTRACTUAL SERVICES |
| 17825 | CITY OF OTTUMWA, CEMETERY | 217195 | 3/3/2023 | 165.00 | CASH INVESTED PASSBK S |
| 18502 | CLUB SENTRY SOFTWARE | 217249 | 3/10/2023 | 32.95 | TECHNOLOGY SERVICES |
| 18980 | CHILD SUPPORT SERVICES | 217317 | 3/17/2023 | 8582.16 | CHILD SUPPORT PAYABLE |
| 20085 | COMPUTER INFORMATION | 217197 | 3/3/2023 | 9500.00 | TECHNOLOGY SERVICES |
| 21808 | CODY CRAYCRAFT | 217250 | 3/10/2023 | 200.00 | SUSTENANCE SUPPLIES |
| 21823 | CREDIT BUREAU SERVICES | 217373 | 3/24/2023 | 240.00 | OTHER PROF SERV |
| 21830 | LORI CREECH | 217374 | 3/24/2023 | 35.58 | TRAVEL & CONFERENCE |
| 22020 | DAN CROSSM0N | 217198 | 3/3/2023 | 85.49 | SUSTENANCE SUPPLIES |
| 22457 | DC CONCRETE & CONST. LLC | 217416 | 3/31/2023 | 47662.35 | CONTRACTUAL SERVICES |
| 22473 | DMACC | 217375 | 3/24/2023 | 140.00 | TRAINING |
| 22479 | D P PLUMBING PLUS | 217376 | 3/24/2023 | 3214.32 | BLDG MAINT & REPAIR |
| 23985 | DENISES ALTERATIONS | 217319 | 3/17/2023 | 25.00 | OTHER PROF SERV |
| 24928 | DINGES FIRE COMPANY | 217320 | 3/17/2023 | 206.64 | TOOLS & SMALL EQUIP |

| | | | |
|---------------------------------|--------|-----------|--------------------------------|
| 27272 ELLIOTT BULK SERVICES LLC | 217251 | 3/10/2023 | 11628.83 VHCL-FUEL |
| 27280 ELLIOTT OIL COMPANY | 217321 | 3/17/2023 | 17203.75 VHCL-FUEL |
| 27535 EMMONS & OLIVER RESOURCES | 217322 | 3/17/2023 | 4800.00 MISCELLANEOUS |
| 27552 EMPOWER RETIREMENT | 217199 | 3/3/2023 | 850.00 HARTFORD DEF COMP PAY. |
| 27786 ENVIRONMENTAL PRODUCTS & | 217324 | 3/17/2023 | 1460.65 VHCL MTCE SUPPLIES |
| 28208 EUROFINS ENVIRONMENT | 217325 | 3/17/2023 | 3582.53 LAB SUPPLIES |
| 28449 EVORA CONSULTING, LTD | 217326 | 3/17/2023 | 6545.00 ENGINEERING |
| 28805 TROY FADIGA | 217327 | 3/17/2023 | 201.60 TRAINING |
| 29829 FIDELITY SECURITY LIFE | 217328 | 3/17/2023 | 5251.45 AVESIS PAYABLE |
| 31459 GRP & ASSOCIATES | 217329 | 3/17/2023 | 52.00 HAZARDOUS WASTE DISPO |
| 33648 GREATER OTTUMWA PARTNERS | 217330 | 3/17/2023 | 5000.00 CONTRACTUAL SERVICES |
| 33653 GREGG YOUNG AUTOMOTIVE | 217253 | 3/10/2023 | 228.14 VHCL MTCE SUPPLIES |
| 34332 HDR ENGINEERING, INC. | 217254 | 3/10/2023 | 6047.26 CAPITAL IMPROVEMENTS |
| 35421 DAVID HARRIS | 217377 | 3/24/2023 | 11500.00 TRAINING |
| 36074 HAWKEYE ENVIRONMENTAL | 217378 | 3/24/2023 | 875.00 CONTRACTUAL SERVICES |
| 36083 HAWKEYE TRUCK EQUIPMENT | 217255 | 3/10/2023 | 2582.15 VHCL MTCE SUPPLIES |
| 36301 HEARTLAND AVIATION | 217256 | 3/10/2023 | 1015.00 RENTS & LEASES |
| 36302 HEARTLAND HUMANE SOCIETY | 217257 | 3/10/2023 | 576.00 OTHER PROF SERV |
| 36401 WILL HECKART | 217200 | 3/3/2023 | 180.00 SUSTENANCE SUPPLIES |
| 37476 HILL PRODUCTIONS & MEDIA | 217258 | 3/10/2023 | 74.00 ADVERT/LEGAL PUBL |
| 37640 JEFFREY HOFFMAN | 217331 | 3/17/2023 | 125.63 TRAINING |
| 38195 HOPKINS & HUBBNER PC | 217332 | 3/17/2023 | 4793.54 LEGAL FEES |
| 39185 HUMANA INSURANCE CO | 217379 | 3/24/2023 | 25081.74 MEDICARE PREMIUMS |
| 39438 HY-VEE ACCOUNTS RECEIVABL | 217380 | 3/24/2023 | 605.85 OPERATING SUPPLIES |
| 40078 ICAP | 217259 | 3/10/2023 | 714268.00 GEN LIABIL INSURANCE |
| 41600 IDEAL READY MIX | 217381 | 3/24/2023 | 4738.31 STREET MAINT SUPPLIES |
| 41920A INDUSTRIAL CHEMICAL | 217202 | 3/3/2023 | 146.00 BUILDING MAINTENANCE RI |
| 42090 INFOMAX OFF SYSTEMS INC | 217261 | 3/10/2023 | 3225.72 PHOTOCOPIES |
| 42160 INGRAM LIBRARY SERVICES | 217262 | 3/10/2023 | 4556.30 LIBRARY MAT-GRUBB ESTA |
| 42170 INLAND TRUCK PARTS & SERV | 217204 | 3/3/2023 | 2164.30 VHCL MTCE SUPPLIES |
| 43290 IAMU | 217382 | 3/24/2023 | 500.00 DUES & MEMBERSHIPS |
| 43465 IOWA COMMUNITIES ASSURANC | 217264 | 3/10/2023 | 25088.00 GEN LIABIL INSURANCE |
| 43506 IOWA DEPT TRANSPORTATION | 217423 | 3/31/2023 | 210.96 VHCL MTCE SUPPLIES |
| 43514 IOWA DEPT NATURAL RESOURC | 217334 | 3/17/2023 | 175.00 MISCELLANEOUS |
| 43785A IOWA HAZMAT TASK FORCE | 217384 | 3/24/2023 | 100.00 DUES & MEMBERSHIPS |
| 43790 IOWA HEART CENTER | 217335 | 3/17/2023 | 298.00 HEART & LUNG EXAM |
| 43835 IOWA HISTORY JOURNAL | 217205 | 3/3/2023 | 35.95 LIBRARY MAT-GRUBB ESTA |
| 43999 IOWA ONE CALL | 217265 | 3/10/2023 | 182.70 TELEPHONE/IT |
| 45044 JEO CONSULTING GROUP, INC | 217206 | 3/3/2023 | 22138.25 MISCELLANEOUS |
| 45057 J & J MOWING | 217387 | 3/24/2023 | 3220.00 CONTRACTUAL SERVICES |
| 45974 JOHN DEERE FINANCIAL | 217207 | 3/3/2023 | 578.63 TOOLS & SMALL EQUIP |
| 48769 KEYSTONE LABORATORIES INC | 217266 | 3/10/2023 | 541.25 LAB SUPPLIES |
| 48800 KIECKS | 217208 | 3/3/2023 | 83.94 OPERATING SUPPLIES |
| 49206 KLODT DOOR SERVICE LLC | 217209 | 3/3/2023 | 271.00 OPERATING SUPPLIES |
| 49500 KNIGHTS OF COLUMBUS | 217210 | 3/3/2023 | 500.00 PROGRAM SUPPLIES |
| 49804D KRONOS, A UKG COMPANY | 217388 | 3/24/2023 | 6320.80 CONTRACTUAL SERVICES |
| 50620 LANGMAN CONSTRUCTION, INC | 217267 | 3/10/2023 | 362809.37 UTILITY SYSTEM |
| 51715 BRIAN LEWIS | 217211 | 3/3/2023 | 68.20 SUSTENANCE SUPPLIES |
| 51968 LIBERTY TIRE | 217425 | 3/31/2023 | 4602.66 TIRE DISPOSAL |
| 52096 LIDTKA ESTATES, LLC | 217426 | 3/31/2023 | 10000.00 CONTRACTUAL SERVICES |
| 52990 LOKTRONICS SECURITY CORP | 217268 | 3/10/2023 | 43.26 OPERATING SUPPLIES |
| 54390 MANATT'S INC | 217427 | 3/31/2023 | 546.10 STREET MAINT SUPPLIES |
| 57195 MCMASTER-CARR | 217269 | 3/10/2023 | 174.78 OPERATING SUPPLIES |
| 57340 MEET OTTUMWA | 217428 | 3/31/2023 | 45348.49 CONV & VISITOR BUREAU |
| 57367 MEDIACOM | 217212 | 3/3/2023 | 229.95 TELEPHONE/IT |

| | | | |
|---------------------------------|--------|-----------|--------------------------------|
| 57385 MENARDS | 217271 | 3/10/2023 | 1044.25 OPERATING SUPPLIES |
| 57518 SYMETRA LIFE INSURANCE CO | 217272 | 3/10/2023 | 4412.93 GROUP LIFE PREMIUMS |
| 58500 MIDAMERICAN ENERGY CO | 217274 | 3/10/2023 | 5066.46 NATURAL GAS |
| 59382 MIDWEST TAPE | 217429 | 3/31/2023 | 174.67 LIBRARY MAT-GRUBB ESTA |
| 60299 MISSIONSQUARE | 217430 | 3/31/2023 | 3646.14 ICMA DEF COMP PAYABLE |
| 60560 MITCHELL & SONS HVAC INC | 217340 | 3/17/2023 | 65.00 OPERATING SUPPLIES |
| 60780 MOBILE LOCKSMITH & ALARM, | 217431 | 3/31/2023 | 277.58 OPERATING SUPPLIES |
| 61785 MOTION INDUSTRIES | 217276 | 3/10/2023 | 263.23 OPERATING SUPPLIES |
| 62580 MUNICIPAL PIPE TOOL CO LL | 217277 | 3/10/2023 | 1495.00 TECHNOLOGY SERVICES |
| 62629 WILL MUNLEY | 217278 | 3/10/2023 | 175.50 TRAINING |
| 65680 NOEL INSURANCE INC | 217390 | 3/24/2023 | 9412.00 PROPERTY INSURANCE |
| 65985 NORSOLV SYSTEMS ENVIRONM | 217341 | 3/17/2023 | 169.95 MISCELLANEOUS |
| 66001 NORRIS ASPHALT PAVING INC | 217342 | 3/17/2023 | 5238.40 STREET MAINT SUPPLIES |
| 66561 OFFICIAL PEST CONTROL | 217391 | 3/24/2023 | 55.00 SUSTENANCE SUPPLIES |
| 66730 OHARA HARDWARE | 217280 | 3/10/2023 | 649.11 OPERATING SUPPLIES |
| 67098 O'REILLY AUTOMOTIVE | 217281 | 3/10/2023 | 843.35 VHCL MTCE SUPPLIES |
| 68238 OTTUMWA HEALTH GROUP LLC | 217343 | 3/17/2023 | 534.00 EMPLOYEE PHYSICALS/TES |
| 68560 OTTUMWA PRINTING, INC. | 217282 | 3/10/2023 | 323.00 OPERATING SUPPLIES |
| 68576 OTTUMWA RADIO | 217345 | 3/17/2023 | 2638.08 EMPLOYEE RECRUITMENT |
| 68588 OTTUMWA REGIONAL HEALTH | 217392 | 3/24/2023 | 556.25 HEART & LUNG EXAM |
| 69040 OTTUMWA WATER AND HYDRO | 217284 | 3/10/2023 | 12300.37 WATER |
| 69259 KATLYN OVERTURF | 217214 | 3/3/2023 | 15.32 VHCL-FUEL |
| 69264 COLE OWENS | 217285 | 3/10/2023 | 62.30 TRAINING |
| 69495 PANTHER UNIFORMS INC | 217215 | 3/3/2023 | 29.50 TOOLS & SMALL EQUIP |
| 69688 DIXIE L PARKER | 217216 | 3/3/2023 | 1600.00 JANITORIAL |
| 71520 PETTY CASH/CITY CLERK | 217347 | 3/17/2023 | 86.46 OFFICE SUPPLIES |
| 72230 PITNEY BOWES BANK INC | 217394 | 3/24/2023 | 1500.00 POSTAGE & SHIPPING |
| 72250 PITNEY BOWES GLOBAL | 217286 | 3/10/2023 | 159.57 RENTS & LEASES |
| 72253 PPG ARCHITECTURAL FINISHE | 217395 | 3/24/2023 | 299.91 OPERATING SUPPLIES |
| 73125 POSTMASTER (CEMETERY) | 217287 | 3/10/2023 | 63.00 POSTAGE & SHIPPING |
| 73290 POWERPLAN | 217217 | 3/3/2023 | 32.73 VHCL MTCE SUPPLIES |
| 73420 PRAIRIE AG SUPPLY INC | 217396 | 3/24/2023 | 4600.00 OTHER CAPITAL EQUIP |
| 73926 PRODUCTIVITY PLUS ACCOUNT | 217288 | 3/10/2023 | 178.71 VHCL MTCE SUPPLIES |
| 73971 PROFESSIONAL JANITORIAL | 217289 | 3/10/2023 | 2740.00 JANITORIAL |
| 74626 QUALITY SERVICES CORP | 217349 | 3/17/2023 | 4965.68 VHCL MTCE SUPPLIES |
| 75160 RANGEMASTERS TRAINING | 217350 | 3/17/2023 | 1795.85 OPERATING SUPPLIES |
| 75902 RECREONICS CORPORATION | 217436 | 3/31/2023 | 247.00 EQUIP REPAIR |
| 76296 CHRISTINA REINHARD | 217351 | 3/17/2023 | 65.50 TRAVEL & CONFERENCE |
| 77196 RIVER HILLS COMMUNITY | 217437 | 3/31/2023 | 5636.00 EMPLOYEE PHYSICALS/TES |
| 77203 RG CONSTRUCTION, LLC | 217220 | 3/3/2023 | 193745.00 CONTRACTUAL SERVICES |
| 77466 ROCHESTER ARMORED CAR | 217397 | 3/24/2023 | 463.31 OTHER PROF SERV |
| 77975 ROTO-ROOTER | 217352 | 3/17/2023 | 359.00 SANITATION |
| 78105 ROYAL PORTABLE TOILETS | 217353 | 3/17/2023 | 965.52 OPERATING SUPPLIES |
| 78279 S & L ALL SEASON | 217221 | 3/3/2023 | 250.00 TOOLS & SMALL EQUIP |
| 78718 SANDRY FIRE SUPPLY LLC | 217354 | 3/17/2023 | 1964.45 OTHER SMALL CAPITAL |
| 79351 SCHROEDER GRAPHICS & SIGN | 217398 | 3/24/2023 | 225.00 VHCL MTCE SUPPLIES |
| 79358 SCHUMACHER ELEVATOR CO | 217355 | 3/17/2023 | 521.06 BUILDING MAINTENANCE RI |
| 81429 AARON SHORT | 217399 | 3/24/2023 | 45.23 TRAVEL & CONFERENCE |
| 82135 SINCLAIR TRACTOR | 217438 | 3/31/2023 | 5.43 VHCL MTCE SUPPLIES |
| 82136 SINCLAIR NAPA | 217292 | 3/10/2023 | 1774.58 VHCL MTCE SUPPLIES |
| 83145 SNYDER WATER | 217439 | 3/31/2023 | 427.00 SUSTENANCE SUPPLIES |
| 83160 SOLENIS | 217400 | 3/24/2023 | 4602.89 OPERATING SUPPLIES |
| 83920 SOUTHERN IOWA ELECTRIC | 217293 | 3/10/2023 | 78.77 ELECTRIC |
| 83928 SOUTHERN IOWA MENTAL HEAL | 217440 | 3/31/2023 | 240.00 EMPLOYEE PHYSICALS/TES |
| 86196 THE STITCH DOCTOR | 217356 | 3/17/2023 | 62.50 SUSTENANCE SUPPLIES |

| | | | |
|------------------------------------|--------|-----------|------------------------------------|
| 86970 SUPREME STAFFING INC | 217401 | 3/24/2023 | 10185.84 CONTRACT EMPLOYEES |
| 87593 TK CONCRETE | 217402 | 3/24/2023 | 419.73 ENGINEERING |
| 88000 TEAMSTER LOCAL UNION 238 | 217441 | 3/31/2023 | 1469.32 POLICE UNION DUES PAYAE |
| 88697 THUMBS UP GIFTS & AWARDS | 217357 | 3/17/2023 | 40.00 OTHER PROF SERV |
| 89073 JEREMY TOSH | 217358 | 3/17/2023 | 11.00 MISCELLANEOUS |
| 89213 TRADEBE ENVIRONMENTAL | 217223 | 3/3/2023 | 7388.65 HAZARDOUS WASTE DISPO |
| 89306 TRANSIT WORKS | 217359 | 3/17/2023 | 536.00 OTHER CAPITAL EQUIP |
| 89855 TRUITT ABSTRACT COMPANY | 217442 | 3/31/2023 | 350.00 LEGAL FEES |
| 90875 UNITED WAY WAPELLO COUNTY | 217443 | 3/31/2023 | 550.00 PROGRAM SUPPLIES |
| 92555 THE VAN METER COMPANY | 217295 | 3/10/2023 | 248.84 OPERATING SUPPLIES |
| 92640 VAUGHN AUTOMOTIVE | 217224 | 3/3/2023 | 753.97 VHCL MTCE SUPPLIES |
| 92648 VEENSTRA & KIMM INC | 217444 | 3/31/2023 | 75314.60 MISCELLANEOUS |
| 92668 VEOLIA WATER TECHNOLOGIES | 217297 | 3/10/2023 | 5235.30 OPERATING SUPPLIES |
| 92681A VERMEER IOWA & N MISSOURI | 217361 | 3/17/2023 | 325.00 VHCL MTCE SUPPLIES |
| 94720 WAPELLO COUNTY SHERIFF | 217225 | 3/3/2023 | 120007.20 OTHER CAPITAL EQUIPMEN |
| 94721 WAPELLO CO SHERIFF'S OFFI | 217226 | 3/3/2023 | 3195.42 DRUG TASK FORCE GRANT |
| 95000 WAPELLO COUNTY UNITED WAY | 217445 | 3/31/2023 | 21.00 UNITED WAY DED PAYABLE |
| 95120 WAPELLO RURAL WATER ASSC | 217298 | 3/10/2023 | 33.25 WATER |
| 95368 WAYNE'S TIRE | 217446 | 3/31/2023 | 2031.92 VHCL MTCE SUPPLIES |
| 95611 WELLMARK BC & BS OF IOWA | 217301 | 3/10/2023 | 205216.57 GROUP HEALTH CLAIMS |
| 96792 WILLETT HOFMANN | 217302 | 3/10/2023 | 4316.14 OTHER PROF SERV |
| 96815 JEFF WILLIAMS | 217227 | 3/3/2023 | 189.75 SUSTENANCE SUPPLIES |
| 97038 WILSON DISTRIBUTOR SERVIC | 217403 | 3/24/2023 | 651.36 OPERATING SUPPLIES |
| 97100 LUKE WIMSATT | 217228 | 3/3/2023 | 292.13 TRAINING |
| 97306 WINDSTREAM ENTERPRISE | 217363 | 3/17/2023 | 1835.41 TELEPHONE/IT |
| 97320 WINGER COMPANIES | 217304 | 3/10/2023 | 2005.40 OPERATING SUPPLIES |
| 97334 WINN CORP | 217305 | 3/10/2023 | 33411.78 STREET MAINT SUPPLIES |
| 97577 WOODRIVER ENERGY LLC | 217404 | 3/24/2023 | 16467.73 NATURAL GAS |
| 98322 DAVID L YEAGER | 217405 | 3/24/2023 | 27.98 GROUNDS MAINT & REPAIR |
| 98541 TIFANI YOUNG | 217230 | 3/3/2023 | 138.86 TRAINING |
| 98820 HEATHER ZUERCHER | 217231 | 3/3/2023 | 30.13 TRAVEL & CONFERENCE |
| IA Dept of Revenue | | 3/1/2023 | 4622.81 Sales Tax |
| Federal Document Management System | | 3/1/2023 | 90.00 Credit Card Equipment Lease |
| IRS | | 3/1/2023 | 75485.39 941 Withholding |
| State of Iowa | | 3/1/2023 | 14124.40 State Withholding |
| Bankcard | | 3/2/2023 | 25.00 Credit Card Fees |
| Advantage Administration Plan Fund | | 3/6/2023 | 2238.09 Payroll Payment |
| Nationwide Payments | | 3/7/2023 | 1490.00 Payroll Payment |
| Municipal Fire & Company | | 3/8/2023 | 124205.52 Fire & Police Retirement |
| Federal Document Management System | | 3/8/2023 | 32.10 Credit Card Equipment Lease |
| Commercial Card Payment | | 3/8/2023 | 96327.84 Purchasing Card |
| Ipers Payment | | 3/9/2023 | 75660.24 Employees Retirement |
| Bankcard | | 3/10/2023 | 132.25 Credit Card Fees |
| IRS | | 3/15/2023 | 75922.00 941 Withholding |
| State of Iowa | | 3/15/2023 | 14366.41 State Withholding |
| Advantage Administration Plan Fund | | 3/20/2023 | 2238.09 Payroll Payment |
| Nationwide Payments | | 3/21/2023 | 1490.00 NRS Payment |
| IRS | | 3/29/2023 | 81066.90 941 Withholding |
| State of Iowa | | 3/29/2023 | 15316.74 State Withholding |
| Total | | | 3209718.34 |

CITY OF OTTUMWA
STATEMENT OF CHANGES IN CASH BALANCE
April, 2023

| ACCOUNT NUMBER | ACCOUNT DESCRIPTION | BEG. PERIOD | CASH | |
|---------------------|---------------------|-----------------|-----------------|-----------------|
| | | BALANCE | DEBITS | CREDITS |
| TOTALS FOR FUND 001 | GENERAL OPER | \$ (691,831.54) | \$ 2,182,340.99 | \$ 1,215,019.34 |
| TOTALS FOR FUND 002 | PARKING RAMP | \$ 54,300.16 | \$ 550.00 | \$ 560.00 |
| TOTALS FOR FUND 003 | GENERAL-ARPA | \$ 3,081,458.10 | | |
| TOTALS FOR FUND 110 | ROAD USE TAX | \$ 5,155,450.71 | \$ 304,405.27 | \$ 253,520.99 |
| TOTALS FOR FUND 112 | EMPLOYEE BEN | \$ 4,705,694.28 | \$ 1,714,675.32 | |
| TOTALS FOR FUND 119 | EMERGENCY FU | \$ 114,497.70 | \$ 62,553.06 | |
| TOTALS FOR FUND 121 | SALES TAX 1% | \$ 9,517,591.00 | \$ 276,070.71 | \$ 448,744.00 |
| TOTALS FOR FUND 122 | ***** | | | |
| TOTALS FOR FUND 123 | AGASSI TIF D | | | |
| TOTALS FOR FUND 124 | VOGEL URBAN | | | |
| TOTALS FOR FUND 125 | WESTGATE TIF | \$ (67,582.32) | \$ 428,580.35 | \$ 384,925.50 |
| TOTALS FOR FUND 126 | AIRPORT TIF | \$ 151,280.17 | \$ 131,502.56 | |
| TOTALS FOR FUND 127 | PENNSYLVANIA | | | |
| TOTALS FOR FUND 128 | WILDWOOD HWY | \$ 92,803.29 | \$ 67,271.45 | |
| TOTALS FOR FUND 129 | RISK MANAGEM | \$ (65,018.07) | \$ 180,572.36 | \$ 113,603.87 |
| TOTALS FOR FUND 131 | AIRPORT FUND | \$ 235,888.63 | \$ 79,393.79 | \$ 125,345.82 |
| TOTALS FOR FUND 133 | LIBRARY FUND | \$ (118,248.99) | \$ 63,410.99 | \$ 59,174.02 |
| TOTALS FOR FUND 135 | CEMETERY FUN | \$ (150,427.07) | \$ 8,742.75 | \$ 27,512.79 |
| TOTALS FOR FUND 137 | HAZ-MAT FUND | \$ 136,880.57 | \$ 19,881.99 | \$ 15,489.23 |
| TOTALS FOR FUND 141 | 2023 UPPER S | \$ (284.79) | | |
| TOTALS FOR FUND 142 | HOAP/HILP ES | | | |
| TOTALS FOR FUND 143 | EPA BROWNFIE | | | |
| TOTALS FOR FUND 144 | 2013 CDBG HO | | | |
| TOTALS FOR FUND 145 | DOWNTOWN REV | | | |
| TOTALS FOR FUND 146 | DOWNTOWN STR | \$ 142,220.06 | | |
| TOTALS FOR FUND 147 | CDBG P-2 MAS | \$ 17,628.32 | | |
| TOTALS FOR FUND 148 | 2016 OWW CDB | | | |
| TOTALS FOR FUND 151 | OTHER BOND P | \$ 2,199,834.76 | \$ 195.00 | \$ 87,265.13 |
| TOTALS FOR FUND 162 | SSMID DISTRI | \$ 69,323.44 | \$ 8,671.50 | |
| TOTALS FOR FUND 167 | FIRE BEQUEST | \$ 14,032.30 | | \$ 2,500.00 |
| TOTALS FOR FUND 169 | START UP/DON | \$ (165.20) | | |
| TOTALS FOR FUND 171 | RETIREE HEAL | \$ (1,698.17) | | |
| TOTALS FOR FUND 173 | LIBRARY BEQU | \$ 85,412.55 | \$ 520.00 | \$ 6,565.32 |
| TOTALS FOR FUND 174 | COMMUNITY DE | \$ 428,653.15 | | \$ 10,000.00 |
| TOTALS FOR FUND 175 | POLICE BEQUE | \$ 174,092.61 | \$ 3,500.00 | \$ 3,809.48 |
| TOTALS FOR FUND 176 | Reimb Grants | \$ (24,205.27) | | |
| TOTALS FOR FUND 177 | HISTORIC PRE | \$ 26,446.09 | | |
| TOTALS FOR FUND 200 | DEBT SERVICE | \$ 2,237,112.30 | \$ 2,196,314.00 | \$ 1,134,650.00 |
| TOTALS FOR FUND 301 | STREET PROJE | \$ 1,633,925.99 | | \$ 139,456.05 |
| TOTALS FOR FUND 303 | AIRPORT PROJ | \$ 358,702.56 | | |
| TOTALS FOR FUND 307 | SIDEWALK & C | \$ 124,913.23 | | \$ 426.43 |
| TOTALS FOR FUND 309 | PARK PROJECT | \$ 1,183,853.92 | | \$ 47,137.28 |
| TOTALS FOR FUND 311 | LEVEE PROJEC | \$ (160,281.86) | | \$ 2,345.05 |
| TOTALS FOR FUND 313 | EVENT CENTER | \$ 1,276,144.77 | | \$ 49,153.11 |
| TOTALS FOR FUND 315 | SEWER CONSTR | \$ 3,322,716.15 | | \$ 797,736.86 |
| TOTALS FOR FUND 320 | WEST END FLO | | | |
| TOTALS FOR FUND 501 | CEMETERY MEM | \$ 2,713.29 | | |
| TOTALS FOR FUND 503 | CEMETERY PER | \$ 526.00 | \$ 405.00 | \$ 526.00 |
| TOTALS FOR FUND 610 | SEWER UTILIT | \$ 3,739,249.73 | \$ 565,342.11 | \$ 680,819.57 |

| | | | | | | | |
|-----------------|-----|---------------|-----------|----------------------|-----------|---------------------|------------------------|
| TOTALS FOR FUND | 611 | SEWER SINKIN | \$ | 1,377,000.00 | | | |
| TOTALS FOR FUND | 612 | STORM WATER | | | | | |
| TOTALS FOR FUND | 613 | SEWER IMPROV | \$ | 4,050,000.00 | \$ | 52,274.00 | |
| TOTALS FOR FUND | 670 | LANDFILL FUN | \$ | 1,715,806.21 | \$ | 109,516.84 | \$ 385,557.08 |
| TOTALS FOR FUND | 671 | LANDFILL RES | \$ | 1,191,555.00 | | | |
| TOTALS FOR FUND | 673 | RECYCLING | \$ | 666,124.15 | \$ | 10,909.04 | \$ 56,440.74 |
| TOTALS FOR FUND | 690 | TRANSIT FUND | \$ | 633,647.22 | | | \$ 107.54 |
| TOTALS FOR FUND | 695 | 1015 TRANSIT | | | | | |
| TOTALS FOR FUND | 720 | BRIDGEVIEW E | \$ | (266,554.16) | | | \$ 41,395.03 |
| TOTALS FOR FUND | 750 | GOLF COURSE | \$ | 40,748.62 | | | |
| TOTALS FOR FUND | 810 | POOLED INVES | \$ | (47,728,533.93) | \$ | 15,764.62 | |
| TOTALS FOR FUND | 820 | PAYROLL CLEA | \$ | 710,789.75 | \$ | 404,070.15 | \$ 598,208.23 |
| TOTALS FOR FUND | 840 | EQUIPMENT PU | \$ | 2,906,356.56 | | | \$ 1,299,780.40 |
| TOTALS FOR FUND | 860 | GROUP HEALTH | \$ | 5,944,189.28 | \$ | 313,774.28 | \$ 218,138.59 |
| TOTALS FOR FUND | 861 | POST 65 RETI | \$ | 260,325.78 | \$ | 9,982.23 | \$ 44,978.06 |
| TOTALS FOR FUND | 862 | DENTAL INSUR | \$ | 60,600.51 | \$ | 7,759.00 | \$ 8,836.34 |
| TOTALS FOR FUND | 863 | LIFE INSURAN | \$ | 41,736.28 | \$ | 4,334.83 | \$ 4,399.43 |
| | | TOTALS | \$ | 10,607,393.82 | \$ | 9,223,284.19 | \$ 8,264,127.28 |

City of Ottumwa
Vender Payment Report
April, 2023

| Vendor # | Vendor Name | Check # | Check Date | Amount | Reason |
|----------|---------------------------|---------|------------|------------|-------------------------|
| 679 | ADVANTAGE ADMINISTRATORS | 217560 | 4/21/2023 | 208.00 | OTHER PROF SERV |
| 690 | AFLAC | 217447 | 4/7/2023 | 3,039.12 | AFLAC DEDUCTION PAYABL |
| 800 | AHLERS & COONEY P.C. | 217518 | 4/12/2023 | 10,846.22 | LEGAL FEES |
| 1700 | ALLIANT ENERGY/IPL | 217519 | 4/12/2023 | 77,432.79 | ELECTRIC |
| 2080 | ALTORFER INC. | 217562 | 4/21/2023 | 4,209.16 | VHCL MTCE SUPPLIES |
| 02080A | ALTORFER | 217563 | 4/21/2023 | 290,600.00 | HEAVY MOTORIZED EQUIP |
| 2592 | AMERICAN BOTTLING COMPANY | 217564 | 4/21/2023 | 690.14 | OPERATING SUPPLIES |
| 3641 | AMERICAN TRAFFIC SAFETY | 217565 | 4/21/2023 | 452.20 | STREET MAINT SUPPLIES |
| 5681 | ATLANTIC BOTTLING COMPANY | 217566 | 4/21/2023 | 278.78 | MERCHANDISE - RESALE |
| 5700 | ATOMIC TERMITE & PEST | 217520 | 4/12/2023 | 130.00 | GROUND MAINT & REPAIR |
| 5860 | AUTOZONE INC | 217567 | 4/21/2023 | 120.84 | STREET MAINT SUPPLIES |
| 5862 | AVFUEL CORP | 217449 | 4/7/2023 | 71,226.00 | AVIATION FUEL |
| 6481 | BAILEY OFFICE OUTFITTERS | 217450 | 4/7/2023 | 3,152.60 | OFFICE SUPPLIES |
| 9352 | BLACKSTONE PUBLISHING | 217636 | 4/28/2023 | 289.99 | LIBRARY MAT-GRUBB ESTA |
| 9360 | BLACK'S TIRE COMPANY LLC | 217452 | 4/7/2023 | 55.00 | VHCL MTCE SUPPLIES |
| 9515 | BLOOMFIELD COMMUNICATIONS | 217570 | 4/21/2023 | 84.24 | TELEPHONE/IT |
| 9562 | BOB BROWN EXCAVATING | 217571 | 4/21/2023 | 6,411.25 | BLDG MAINT & REPAIR |
| 10233 | C & C MANUFACTURING, LLC | 217572 | 4/21/2023 | 170.38 | VHCL MTCE SUPPLIES |
| 11495 | BRIDGE CITY TRUCK REPAIR | 217453 | 4/7/2023 | 187.25 | VHCL MTCE SUPPLIES |
| 11496 | BRIDGE CITY SANITATION LL | 217574 | 4/21/2023 | 158,837.77 | OTHER PROF SERV |
| 11506 | BRIDGE VIEW CENTER | 217454 | 4/7/2023 | 2,932.35 | OPERATING SUPPLIES |
| 12500 | BUB'S TREE CARE | 217575 | 4/21/2023 | 7,500.00 | TREE TRIMMING |
| 12605 | BUDGET RESTAURANT SUPPLY | 217576 | 4/21/2023 | 1,960.87 | OPERATING SUPPLIES |
| 14317 | CAPITAL ONE | 217456 | 4/7/2023 | 263.46 | PROGRAM SUPPLIES |
| 14318A | CAPITAL CITY EQUIPMENT CO | 217522 | 4/12/2023 | 26.05 | VHCL MTCE SUPPLIES |
| 15760 | CARROLL CONSTRUCTION SUPP | 217457 | 4/7/2023 | 546.71 | STREET MAINT SUPPLIES |
| 15788 | CATERPILLAR GLOBAL SERVIC | 217577 | 4/21/2023 | 5,281.86 | VHCL MTCE SUPPLIES |
| 16300 | CENTRAL IOWA FASTENERS | 217458 | 4/7/2023 | 738.26 | MISCELLANEOUS |
| 16301 | CENTRAL IOWA DISTRIBUTING | 217578 | 4/21/2023 | 8,128.00 | BLDG MAINT & REPAIR |
| 16402 | CENTURYLINK | 217580 | 4/21/2023 | 1,646.21 | TELEPHONE/IT |
| 16403 | CENTURYLINK | 217523 | 4/12/2023 | 6.55 | TELEPHONE/IT |
| 17694 | CITY OF BLOOMFIELD | 217460 | 4/7/2023 | 2,500.00 | SUSTENANCE SUPPLIES |
| 17825 | CITY OF OTTUMWA, CEMETERY | 217461 | 4/7/2023 | 526.00 | CASH INVESTED PASSBK SV |
| 17945 | CIVICPLUS | 217462 | 4/7/2023 | 189.47 | OTHER PROF SERV |
| 18502 | CLUB SENTRY SOFTWARE | 217463 | 4/7/2023 | 32.95 | TECHNOLOGY SERVICES |
| 18980 | CHILD SUPPORT SERVICES | 217640 | 4/28/2023 | 5,816.10 | CHILD SUPPORT PAYABLE |
| 22479 | D P PLUMBING PLUS | 217464 | 4/7/2023 | 8,994.79 | CAPITAL IMPROVEMENTS |
| 22608 | DANI'S AUTO SUPPLY LLC | 217641 | 4/28/2023 | 84.23 | VHCL MTCE SUPPLIES |
| 24330 | DERANS TOWING SERVICE | 217581 | 4/21/2023 | 400.00 | VHCL MTCE SUPPLIES |
| 24375 | DESIGN WORKSHOP, INC | 217642 | 4/28/2023 | 18,000.00 | COMPREHENSIVE PLAN |
| 25394 | DRISH CONSTRUCTION, INC. | 217465 | 4/7/2023 | 44,466.65 | MISCELLANEOUS |
| 25593 | DXP ENTERPRISES, INC. | 217466 | 4/7/2023 | 42.46 | OPERATING SUPPLIES |
| 26640 | ECOSYSTEMS INC | 217582 | 4/21/2023 | 42,162.34 | SLUDGE HAULING |
| 27005 | ELECTRIC PUMP, INC. | 217583 | 4/21/2023 | 33,232.39 | CAPITAL IMPROVEMENTS |
| 27280 | ELLIOTT OIL COMPANY | 217644 | 4/28/2023 | 32,149.18 | VHCL-FUEL |
| 27552 | EMPOWER RETIREMENT | 217645 | 4/28/2023 | 500.00 | HARTFORD DEF COMP PAY/ |
| 27784 | ENVIRONMENTAL PRODUCTS & | 217526 | 4/12/2023 | 2,611.76 | VHCL MTCE SUPPLIES |
| 27826 | DIVA EPISOM | 217646 | 4/28/2023 | 100.00 | REFUNDS |
| 28208 | EUROFINS ENVIRONMENT | 217647 | 4/28/2023 | 12,457.54 | CELL DEVELOPMENT |

| | | | | |
|----------------------------------|--------|-----------|------------|-------------------------|
| 29300 FASTENAL COMPANY | 217586 | 4/21/2023 | 386.99 | OPERATING SUPPLIES |
| 29750 KEN FESKE | 217587 | 4/21/2023 | 50.01 | SUSTENANCE SUPPLIES |
| 30130 1ST AYD CORPORATION | 217588 | 4/21/2023 | 302.27 | MISCELLANEOUS |
| 31366 FRIENDS OF THE GRIMES | 217470 | 4/7/2023 | 225.00 | CONTRACTUAL SERVICES |
| 31382 FRONTLINE WARNING SYSTEMS | 217527 | 4/12/2023 | 59,046.00 | GROUNDS MAINT & REPAIR |
| 31459 GRP & ASSOCIATES | 217528 | 4/12/2023 | 367.00 | HAZARDOUS WASTE DISPO |
| 33010 GOODWIN TUCKER GROUP | 217471 | 4/7/2023 | 1,235.40 | BLDG MAINT & REPAIR |
| 33397 BRANDON GRAVETT | 217650 | 4/28/2023 | 200.00 | SUSTENANCE SUPPLIES |
| 33653 GREGG YOUNG AUTOMOTIVE | 217472 | 4/7/2023 | 550.07 | VHCL MTCE SUPPLIES |
| 34332 HDR ENGINEERING, INC. | 217529 | 4/12/2023 | 11,897.61 | CAPITAL IMPROVEMENTS |
| 34894 JEFFREY HAMANN | 217530 | 4/12/2023 | 120.00 | MISCELLANEOUS |
| 34966 HARDY DIAGNOSTICS | 217651 | 4/28/2023 | 182.13 | LAB SUPPLIES |
| 36092 HAWKEYE POLYGRAPH | 217590 | 4/21/2023 | 350.00 | OTHER PROF SERV |
| 36301 HEARTLAND AVIATION | 217473 | 4/7/2023 | 635.00 | RENTS & LEASES |
| 36302 HEARTLAND HUMANE SOCIETY | 217474 | 4/7/2023 | 5,210.00 | DOG LICENSES |
| 36355 HEARTLAND SCENIC STUDIO I | 217475 | 4/7/2023 | 27,576.00 | BLDG MAINT & REPAIR |
| 37423 BRAD HIGGINS | 217652 | 4/28/2023 | 200.00 | SUSTENANCE SUPPLIES |
| 37476 HILL PRODUCTIONS & MEDIA | 217531 | 4/12/2023 | 74.00 | ADVERT/LEGAL PUBL |
| 39125 MICKEY HUCKS | 217653 | 4/28/2023 | 23.94 | MISCELLANEOUS |
| 39185 HUMANA INSURANCE CO | 217654 | 4/28/2023 | 24,182.46 | MEDICARE PREMIUMS |
| 39438 HY-VEE ACCOUNTS RECEIVABL | 217592 | 4/21/2023 | 103.80 | SUSTENANCE SUPPLIES |
| 39439 HYVEE | 217656 | 4/28/2023 | 2,361.52 | TRAVEL & CONFERENCE |
| 41505A IMWCA | 217532 | 4/12/2023 | 107,106.17 | POLICE W/C 411 CLAIMS |
| 41511 IOWA COUNTY AMBULANCE | 217533 | 4/12/2023 | 12,500.00 | OTHER CAPITAL EQUIPMEN |
| 41600 IDEAL READY MIX | 217593 | 4/21/2023 | 12,671.36 | STREET MAINT SUPPLIES |
| 41754 INDIAN HILLS COMMUNITY | 217478 | 4/7/2023 | 160.00 | TRAINING |
| 41920A INDUSTRIAL CHEMICAL | 217479 | 4/7/2023 | 148.00 | BUILDING MAINTENANCE RE |
| 41925 INDUSTRIAL MEDICINE | 217534 | 4/12/2023 | 40.00 | EMPLOYEE PHYSICALS/TES |
| 42090 INFOMAX OFF SYSTEMS INC | 217480 | 4/7/2023 | 2,442.10 | PHOTOCOPIES |
| 42160 INGRAM LIBRARY SERVICES | 217594 | 4/21/2023 | 2,759.00 | LIBRARY MAT-GRUBB ESTA |
| 42342A INTEGRITY ELECTRIC | 217481 | 4/7/2023 | 4,246.05 | BLDG MAINT & REPAIR |
| 43265 INTERSTATE BATTERY | 217535 | 4/12/2023 | 298.90 | VHCL MTCE SUPPLIES |
| 43275 INTERSTATE INDUS. SERVICE | 217536 | 4/12/2023 | 810.92 | VHCL MTCE SUPPLIES |
| 43506 IOWA DEPT TRANSPORTATION | 217515 | 4/10/2023 | 430.00 | MISCELLANEOUS |
| 43525 IOWA DEPT NATURAL RESOURC | 217516 | 4/10/2023 | 20.00 | TRAINING |
| 43880A IA LAW ENFORCEMENT ACADEM | 217658 | 4/28/2023 | 1,125.00 | TRAINING |
| 43999 IOWA ONE CALL | 217659 | 4/28/2023 | 208.80 | TELEPHONE/IT |
| 45057 J & J MOWING | 217660 | 4/28/2023 | 7,457.50 | CONTRACTUAL SERVICES |
| 45616 JERRY'S TREE SERVICE | 217484 | 4/7/2023 | 1,540.00 | TREE TRIMMING |
| 46694 JONES CONTRACTING CORP | 217485 | 4/7/2023 | 94,536.43 | CONTRACTUAL SERVICES |
| 49206 KLODT DOOR SERVICE LLC | 217537 | 4/12/2023 | 110.00 | GROUNDS MAINT & REPAIR |
| 49804D KRONOS, A UKG COMPANY | 217538 | 4/12/2023 | 5,876.29 | CONTRACTUAL SERVICES |
| 50467 EDMOND LAIBWIJ | 217661 | 4/28/2023 | 100.00 | REFUNDS |
| 50620 LANGMAN CONSTRUCTION, INC | 217486 | 4/7/2023 | 757,181.54 | UTILITY SYSTEM |
| 51417 LEGACY FIRE APPARATUS | 217487 | 4/7/2023 | 3,619.91 | VHCL MTCE SUPPLIES |
| 51968 LIBERTY TIRE | 217662 | 4/28/2023 | 4,602.66 | TIRE DISPOSAL |
| 51969 LIBERTY TIRE SERVICES LLC | 217596 | 4/21/2023 | 1,918.88 | TIRE DISPOSAL |
| 52990 LOKTRONICS SECURITY CORP | 217540 | 4/12/2023 | 528.64 | OPERATING SUPPLIES |
| 53691 MACQUEEN EQUIPMENT | 217541 | 4/12/2023 | 205,538.38 | HEAVY MOTORIZED EQUIP |
| 54057 MAHASKA COMMUNICATION GR | 217663 | 4/28/2023 | 52.00 | TECHNOLOGY SERVICES |
| 54187 MAIN STREET OTTUMWA | 217664 | 4/28/2023 | 9,784.50 | DOWNTOWN MAINTENANCE |
| 54390 MANATT'S INC | 217598 | 4/21/2023 | 2,486.05 | STREET MAINT SUPPLIES |
| 55307 MAST OVERHEAD DOORS INC | 217488 | 4/7/2023 | 6,459.54 | OPERATING SUPPLIES |
| 55335 MC2, INC | 217665 | 4/28/2023 | 1,159.79 | OPERATING SUPPLIES |
| 56097 FORREST MCCURREN | 217666 | 4/28/2023 | 400.00 | PROGRAM SUPPLIES |

| | | | | | |
|-------|---------------------------|--------|-----------|-----------|-------------------------|
| 56656 | MCKEE CONSTRUCTION AND | 217489 | 4/7/2023 | 54,300.00 | CONTRACTUAL SERVICES |
| 57385 | MENARDS | 217601 | 4/21/2023 | 2,002.36 | STREET MAINT SUPPLIES |
| 57518 | SYMETRA LIFE INSURANCE CO | 217490 | 4/7/2023 | 4,399.43 | GROUP LIFE PREMIUMS |
| 58500 | MIDAMERICAN ENERGY CO | 217492 | 4/7/2023 | 3,934.35 | NATURAL GAS |
| 58555 | MID-IOWA SOLID WASTE | 217603 | 4/21/2023 | 5,526.59 | VHCL MTCE SUPPLIES |
| 59382 | MIDWEST TAPE | 217669 | 4/28/2023 | 85.45 | LIBRARY MAT-GRUBB ESTA |
| 60299 | MISSIONSQUARE | 217670 | 4/28/2023 | 2,430.76 | ICMA DEF COMP PAYABLE |
| 60554 | CALEB MITCHELL | 217493 | 4/7/2023 | 19.70 | TRAVEL & CONFERENCE |
| 60780 | MOBILE LOCKSMITH & ALARM, | 217671 | 4/28/2023 | 255.00 | MISCELLANEOUS |
| 61785 | MOTION INDUSTRIES | 217494 | 4/7/2023 | 1,252.53 | OPERATING SUPPLIES |
| 62580 | MUNICIPAL PIPE TOOL CO LL | 217495 | 4/7/2023 | 4,640.15 | VHCL MTCE SUPPLIES |
| 64566 | PHILLIP NAYLOR | 217605 | 4/21/2023 | 10,000.00 | CAPITAL IMPROVEMENTS |
| 65617 | WASEEM NISAR | 217606 | 4/21/2023 | 2,000.00 | MISCELLANEOUS |
| 65680 | NOEL INSURANCE INC | 217673 | 4/28/2023 | 100.00 | DUES & MEMBERSHIPS |
| 66001 | NORRIS ASPHALT PAVING INC | 217607 | 4/21/2023 | 3,172.02 | STREET MAINT SUPPLIES |
| 66561 | OFFICIAL PEST CONTROL | 217546 | 4/12/2023 | 55.00 | SUSTENANCE SUPPLIES |
| 67058 | ONSITE SERVICE SOLUTIONS | 217496 | 4/7/2023 | 1,687.50 | CONTRACTUAL SERVICES |
| 67098 | O'REILLY AUTOMOTIVE | 217608 | 4/21/2023 | 926.70 | VHCL MTCE SUPPLIES |
| 68238 | OTTUMWA HEALTH GROUP LLC | 217674 | 4/28/2023 | 427.00 | EMPLOYEE PHYSICALS/TES |
| 68560 | OTTUMWA PRINTING, INC. | 217609 | 4/21/2023 | 1,455.00 | PRINTING |
| 69040 | OTTUMWA WATER AND HYDRO | 217497 | 4/7/2023 | 12,088.00 | BILLING FEES-WW |
| 69201 | OVERHEAD DOOR CO. OF OTTU | 217548 | 4/12/2023 | 602.60 | OPERATING SUPPLIES |
| 69322 | PBL LIMITED | 217498 | 4/7/2023 | 16.00 | LIBRARY MAT-GRUBB ESTA |
| 69688 | DIXIE L PARKER | 217499 | 4/7/2023 | 1,600.00 | JANITORIAL |
| 70009 | PARKER TREE SERVICE | 217500 | 4/7/2023 | 2,400.00 | CONTRACTUAL SERVICES |
| 71625 | PETTY CASH OTTUMWA PARK | 217501 | 4/7/2023 | 200.00 | CAMPING FEES |
| 72253 | PPG ARCHITECTURAL FINISHE | 217676 | 4/28/2023 | 20.27 | OPERATING SUPPLIES |
| 73290 | POWERPLAN | 217611 | 4/21/2023 | 392.81 | VHCL MTCE SUPPLIES |
| 73420 | PRAIRIE AG SUPPLY INC | 217677 | 4/28/2023 | 759.20 | TOOLS & SMALL EQUIP |
| 73490 | DXP ENTERPRISES, INC | 217612 | 4/21/2023 | 165.92 | OPERATING SUPPLIES |
| 73971 | PROFESSIONAL JANITORIAL | 217502 | 4/7/2023 | 2,820.00 | JANITORIAL |
| 74626 | QUALITY SERVICES CORP | 217549 | 4/12/2023 | 335.36 | VHCL MTCE SUPPLIES |
| 75142 | GENE RATHJE | 217503 | 4/7/2023 | 183.40 | TRAVEL & CONFERENCE |
| 76053 | REED OVERHEAD DOOR | 217504 | 4/7/2023 | 305.30 | OPERATING SUPPLIES |
| 76296 | CHRISTINA REINHARD | 217678 | 4/28/2023 | 111.22 | TRAVEL & CONFERENCE |
| 76345 | REPUBLIC COMPANIES | 217679 | 4/28/2023 | 560.00 | HAZARDOUS WASTE DISPO |
| 77196 | RIVER HILLS COMMUNITY | 217680 | 4/28/2023 | 2,830.00 | EMPLOYEE PHYSICALS/TES |
| 77203 | RG CONSTRUCTION, LLC | 217613 | 4/21/2023 | 23,841.20 | CAPITAL IMPROVEMENTS |
| 77204 | RIPPLING WATERS | 217551 | 4/12/2023 | 10,000.00 | 15155306413 |
| 77466 | ROCHESTER ARMORED CAR | 217614 | 4/21/2023 | 454.65 | OTHER PROF SERV |
| 77522 | SHAUNA ROEFER | 217615 | 4/21/2023 | 2,500.00 | CONTRACTUAL SERVICES |
| 77965 | ROTARY CLUB OF OTTUMWA | 217552 | 4/12/2023 | 320.00 | DUES & MEMBERSHIPS |
| 77975 | ROTO-ROOTER | 217616 | 4/21/2023 | 166.00 | MISC CONTRACT WORK |
| 78105 | ROYAL PORTABLE TOILETS | 217617 | 4/21/2023 | 220.32 | OPERATING SUPPLIES |
| 78177 | BLAISE RUPE | 217681 | 4/28/2023 | 133.74 | SUSTENANCE SUPPLIES |
| 78279 | S & L ALL SEASON | 217553 | 4/12/2023 | 92.95 | TOOLS & SMALL EQUIP |
| 78293 | SCS ENGINEERS | 217618 | 4/21/2023 | 2,684.07 | CONTRACTUAL SERVICES |
| 78718 | SANDRY FIRE SUPPLY LLC | 217505 | 4/7/2023 | 2,795.52 | EQUIP REPAIR |
| 79358 | SCHUMACHER ELEVATOR CO | 217619 | 4/21/2023 | 926.06 | BUILDING MAINTENANCE RE |
| 79970 | LARRY SEALS | 217506 | 4/7/2023 | 12.00 | TRAVEL & CONFERENCE |
| 81372 | SHIVE-HATTERY ENGINEERS | 217507 | 4/7/2023 | 27,046.20 | ENGINEERING |
| 81449 | SHOTTENKIRK | 217620 | 4/21/2023 | 349.85 | VHCL MTCE SUPPLIES |
| 82136 | SINCLAIR NAPA | 217621 | 4/21/2023 | 733.80 | VHCL MTCE SUPPLIES |
| 83880 | SOUTHERN IOWA DIESEL, INC | 217622 | 4/21/2023 | 728.39 | EQUIP REPAIR |
| 83920 | SOUTHERN IOWA ELECTRIC | 217554 | 4/12/2023 | 78.91 | ELECTRIC |

| | | | | | |
|-------|------------------------------------|--------|-----------|---------------------|-----------------------------|
| 84100 | SPILMAN AUTO PARTS INC | 217623 | 4/21/2023 | 110.00 | VHCL MTCE SUPPLIES |
| 84947 | STANARD & ASSOC INC | 217508 | 4/7/2023 | 94.00 | OTHER PROF SERV |
| 85289 | JORDAN STATON | 217509 | 4/7/2023 | 17.13 | TRAVEL & CONFERENCE |
| 86196 | THE STITCH DOCTOR | 217624 | 4/21/2023 | 584.50 | SUSTENANCE SUPPLIES |
| 86970 | SUPREME STAFFING INC | 217683 | 4/28/2023 | 34,751.88 | CONTRACTUAL SERVICES |
| 87230 | SUTPHEN CORPORATION | 217517 | 4/10/2023 | 1,095,169.40 | HEAVY MOTORIZED EQUIP |
| 88000 | TEAMSTER LOCAL UNION 238 | 217684 | 4/28/2023 | 1,543.56 | POLICE UNION DUES PAYAE |
| 89072 | TORRES CONSTRUCTION | 217685 | 4/28/2023 | 2,400.00 | CONTRACTUAL SERVICES |
| 89855 | TRUITT ABSTRACT COMPANY | 217625 | 4/21/2023 | 175.00 | LEGAL FEES |
| 92555 | THE VAN METER COMPANY | 217626 | 4/21/2023 | 670.68 | STREET MAINT SUPPLIES |
| 92640 | VAUGHN AUTOMOTIVE | 217686 | 4/28/2023 | 282.68 | VHCL MTCE SUPPLIES |
| 92648 | VEENSTRA & KIMM INC | 217687 | 4/28/2023 | 36,336.08 | MISCELLANEOUS |
| 94720 | WAPELLO COUNTY SHERIFF | 217557 | 4/12/2023 | 8,963.37 | NATURAL GAS |
| 95000 | WAPELLO COUNTY UNITED WAY | 217688 | 4/28/2023 | 14.00 | UNITED WAY DED PAYABLE |
| 95120 | WAPELLO RURAL WATER ASSC | 217510 | 4/7/2023 | 45.23 | WATER |
| 95368 | WAYNE'S TIRE | 217627 | 4/21/2023 | 720.66 | VHCL MTCE SUPPLIES |
| 95611 | WELLMARK BC & BS OF IOWA | 217558 | 4/12/2023 | 247,562.53 | GROUP HEALTH CLAIMS |
| 96525 | JAY WHEATON | 217511 | 4/7/2023 | 180.00 | SUSTENANCE SUPPLIES |
| 96792 | WILLETT HOFMANN | 217512 | 4/7/2023 | 4,970.00 | ENGINEERING |
| 97306 | WINDSTREAM ENTERPRISE | 217559 | 4/12/2023 | 938.03 | TELEPHONE/IT |
| 97320 | WINGER COMPANIES | 217629 | 4/21/2023 | 2,138.50 | BLDG MAINT & REPAIR |
| 97334 | WINN CORP | 217630 | 4/21/2023 | 26,907.36 | STREET MAINT SUPPLIES |
| 97577 | WOODRIVER ENERGY LLC | 217691 | 4/28/2023 | 10,895.41 | NATURAL GAS |
| 98320 | YATES & YATES GLASS CO IN | 217631 | 4/21/2023 | 4,704.00 | OTHER SMALL CAPITAL |
| 98684 | ZIMMER & FRANCESCON INC | 217632 | 4/21/2023 | 14,065.70 | OTHER MAINT & REPAIR |
| | Advantage Administration Plan Fund | | 4/3/2023 | 2,238.09 | Payroll Payment |
| | Iowa Dept of Revenue | | 4/3/2023 | 2,124.77 | Sales Tax |
| | Federal Document Management System | | 4/3/2023 | 90.00 | Credit Card Equipment Lease |
| | Bankcard | | 4/3/2023 | 25.00 | Credit Card Fees |
| | Nationwide Payments | | 4/4/2023 | 1,490.00 | Payroll Payment |
| | Municipal Fire & Company | | 4/7/2023 | 184,724.00 | Fire & Police Retirement |
| | Federal Document Management System | | 4/7/2023 | 32.10 | Credit Card Equipment Lease |
| | Merchant Services | | 4/7/2023 | 7.33 | Credit Cards Fees |
| | Commercial Card Payment | | 4/10/2023 | 86,664.31 | Purchasing Card |
| | Ipers Payroll | | 4/11/2023 | 114,583.33 | Employees Retirement |
| | Bankcard | | 4/12/2023 | 198.63 | Credit Card Fees |
| | IRS | | 4/12/2023 | 75,522.92 | 941 Withholding |
| | State of Iowa | | 4/12/2023 | 14,212.72 | State Withholding |
| | Advantage Administration Plan Fund | | 4/17/2023 | 2,238.09 | Payroll Payment |
| | Nationwide Payments | | 4/18/2023 | 1,490.00 | Payroll Payment |
| | IRS | | 4/26/2023 | 77,384.22 | 941 Withholding |
| | State of Iowa | | 4/26/2023 | 14,597.68 | State Withholding |
| | UMB Corp Trust | | 4/27/2023 | 1,134,650.00 | Bond Payments |
| | Total | | | <u>5,648,971.69</u> | |



June 20, 2023

TO: Ottumwa City Council Members

FROM: Richard W. Johnson, Mayor

SUBJECT: APPOINTMENT TO CITY BOARDS AND/OR COMMISSIONS

Recommend appointment to the Cemetery Board of Trustees, term to expire 07/01/2028 due to a vacancy.

James Carlson
1419 Sunrise Circle

Recommend re-appointment to the Board of Library Trustees, term to expire 07/01/2029.

Joyce Kramer
#4 Country Club Place

Recommend re-appointment to the Cemetery Board of Trustees, term to expire 07/01/2030.

John Hunolt
147 E. Court

Recommend re-appointments to the Human Rights Commission, term to expire 07/01/2026.

Amy Norris Hernandez
57 Kingsley Drive

Nathan Wilson
503 Indian Trail Road

Gaylon Davis
214 South Ransom

CITY OF OTTUMWA
Biographical Data for Appointment to City Advisory Board

The information contained on this form is for the use of the Mayor and City Council in order to fill vacancies on City Advisory Boards Commissions, Committees, or Task Forces.

Biographical forms may be submitted at any time during the year; however, they will be purged January 31 of each year. If you have not been appointed to an advisory board during the preceding year, and still desire appointment, please resubmit an updated biographical form or advise in writing that the initial form is still usable.

Board, Commission, Committee, or Task Force to which appointment is desired:

Cemetery

Name: James Carlson Telephone: 641-455-8993

Email: (optional) jmarc195364@yaho.com

Address: 1419 Sunrise Circle ZIP: 52501

Business: retired Telephone: _____

Address: _____ ZIP: _____

Date Available for Appointment any E-Mail: _____

Present occupation: retired

Previous Employment: Iowa DHS, Ottumwa Housing Authority

Answer the following: (Use additional sheets if necessary)

Community Service:

(List boards, commissions, committees and organizations currently serving or have served on, offices held and in what city).

Southern Iowa Mental Health Center Board past
Retired Senior Volunteer Program Board past
Area Agency on Aging Board past
Ottumwa Housing Authority Board past
Iowa Junior High host parent volunteer past
Wapello County Historical Society Board past
First Lutheran Church Board past
Travelers Protective Association

Please list any professional or vocational licenses or certificates you hold.

Personal:

(Have you ever worked for the City of Ottumwa?)

Yes _____ No _____
Ottumwa Housing Authority

(If yes, please list dates and names of departments)

Are you related to any employee or appointee of the City of Ottumwa? (If yes, please indicate name and relationship.)

Yes _____ No

Rules of law and ethics prohibit members from participating in and voting on matters in which they pay have a direct or indirect financial interest. Are you aware of any potential conflicts of interest which may develop from your occupation or financial holdings in relation to your responsibilities as a member of the advisory body to which you seek appointment). (If yes, please indicate any potential conflicts).

Yes _____ No

Are you aware of the time commitment necessary to fulfill the obligations of the advisory body to which you seek appointment?

Yes No _____

Please furnish brief written responses to the three following questions: (Use additional sheets if necessary.)

1. What is there specifically in your background, training, education, or interests which qualifies you as an appointee?

extensive experience with community issues

2. What do you see as the objectives and goals of the advisory body to which you seek appointment?

make recommendations to the city regarding the operation of Ottumwa Cemetery

3. How would you help achieve these objectives and goals? What special qualities can you bring to the advisory body?

work with other board members and staff

I hereby certify that the following information is correct to the best of my knowledge.

James M. Carbo
Signature

5-25-23
Date

You are invited to attach additional pages or submit supplemental information which you feel may assist the Mayor and City Council in their evaluation of your application.

WHEN COMPLETED MAIL ORIGINAL TO:

OFFICE OF THE MAYOR
Ottumwa City Hall
105 E Third Street
Ottumwa, IA 52501

**YOUTH BOARD
MEMBER APPLICANT ONLY**

Name of School

Year

**HUMAN RIGHTS COMMISSION
MEMBER APPLICANT ONLY**

The Human Rights Commission seeks to model service leadership and respect in its work with Commission members and the community. List your experience working on diverse teams, public bodies, or committees, and skills related to intergroup dialogues and team building with diverse communities:



CITY OF
OTTUMWA

One of the goals of the City Council is to balance advisory board appointments with respect to areas of expertise, advocacy experience, community involvement, profession, education, race, creed, ethnicity, color, sex, sexual orientation, gender identity, national origin, age, religion, disability and geographic identification. Addressing any or all of these factors in your application will help the Mayor and City Council assess your application.

OPTIONAL

The following information is desirable but not required for appointment. Please complete any of the information requested below to the best of your knowledge. Failure to fill in any or all of the information does NOT disqualify applicants from consideration.

| | |
|----------------------------|--|
| Areas of expertise | <u>public assistance related</u> |
| Advocacy experience | <u>social work</u> |
| Community involvement | <u>Iowa DHS, OHA</u> |
| Current profession | <u>retired</u> |
| Highest level of education | <u>B.S + grad. hrs in management & social work</u> |
| Race | <u>w</u> |
| Creed | <u></u> |
| Ethnicity | <u></u> |
| Color | <u></u> |
| Sex | <u>m</u> |
| Sexual orientation | <u>m</u> |
| Gender identity | <u>m</u> |
| National origin | <u>Swedish-American</u> |
| Age | <u>80</u> |
| Religion | <u>Lutheran</u> |
| Disability | <u></u> |

received
@6.9.23 3:50pm

CITY OF OTTUMWA
Staff Summary

**** ACTION ITEM ****

Council Meeting of: Jun 20, 2023

Administration
Department

Barbara Codjoe
Prepared By
Barbara Codjoe
Department Head



City Administrator Approval

AGENDA TITLE: Resolution #96-2023 - Approve updated Salary Schedule

Public hearing required if this box is checked.

RECOMMENDATION: Pass and adopt resolution #96 - 2023

DISCUSSION: Changes are as follows:

- 1) Salary set for the Aviation Service Supervisor passed by resolution 272-2022 on 11/15/2022 added to the schedule.
- 2) Salary increase for Director of Community Development Director passed at City Council meeting on 05/02/2023.
- 2) Salary increase for the Assistant Library Director as passed at the Board of Trustees meeting on Monday 05/08/2023 updated on schedule.

Source of Funds: N/A

Budgeted Item: Budget Amendment Needed:

RESOLUTION NO. 96-2023

RESOLUTION APPROVING UPDATED SALARY SCHEDULE

WHEREAS, the Aviation Services Supervisor salary has been added as passed by resolution 272-2022 on 11/15/2022; and

WHEREAS, the Director of Community Development salary has been corrected as per increase passed at City Council meeting on 05/02/202; and

WHEREAS, the Assistant Library Director salary was set by the Library Board of Trustees on 05/08/2023.

NOW, THEREFORE, BE IT RESOLVED, by the City Council of the City of Ottumwa, Iowa, that the three positions of Aviation Service Supervisor, Director of Community Development and Assistant Library Director are accurately reflected; and



BE IT FURTHER RESOLVED, by the Ottumwa City Council of the City of Ottumwa, Iowa, that the Mayor and City Clerk are hereby authorized and directed to execute said resolution.

APPROVED, PASSED AND ADOPTED, this 20th day of June, 2023.

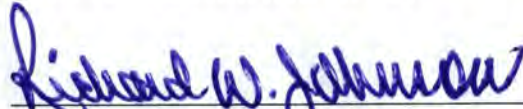
CITY OF OTTUMWA, IOWA

Richard W. Johnson, Mayor

ATTEST:



Christina Reinhard, City Clerk

CITY OF OTTUMWA SALARY SCHEDULE
Fiscal Year 2023

The compensation schedule identified below reflects the base wage or salary for individuals in the identified non-represented¹ position. The wage or salary identified below or in the compensation schedule (grade and step) is the base pay and does not reflect an individual employee's longevity or other compensation modifiers now or in the future.

DEPARTMENT HEADS

CITY ADMINISTRATOR
\$153,026*

DIRECTOR OF FINANCE
\$116,002*

DIRECTOR OF PUBLIC WORKS
\$109,054*

POLICE CHIEF
\$103,022*

FIRE CHIEF
\$102,814*

DIRECTOR OF COMMUNITY DEVELOPMENT
\$97,510.40*

DIRECTOR OF PARK, RECREATION & CEMETERY
\$90,854*

DIRECTOR OF HUMAN RESOURCES
\$88,233*

DIRECTOR OF AIRPORT SERVICES
\$83,262*

DIRECTOR OF LIBRARY SERVICES
\$82,014.40 (updated 04/11/2022)*#

CITY CLERK
\$67,122*

OTHER SUPERVISORY POSITIONS

ASSISTANT DIRECTOR OF LIBRARY SERVICES
\$55,972.80 (updated 04/11/2022)*#

LANDFILL SUPERVISOR
\$60,008*@

¹ Non-Represented is an employee not covered or identified under a Collective Bargaining Agreement (CBA)

AVIATION SERVICES SUPERVISOR

\$83,262*

*Compensation is rounded to the nearest whole dollar.

#Current compensation as established by the Board of Library Trustees

@Current compensation as established by the Solid Waste Commission

GENERAL SERVICE EMPLOYEES

No one at present (02)

Secretary (04)

Administrative Assistant**

| GSB1 | GSB2 | GSB3 | GSB4 | GSB5 | GSB6 |
|-------|-------|-------|-------|-------|-------|
| 17.65 | 18.55 | 19.44 | 20.46 | 21.44 | 22.57 |

Zoning Technician (06)

| GSC1 | GSC2 | GSC3 | GSC4 | GSC5 | GSC6 |
|-------|-------|-------|-------|-------|-------|
| 18.55 | 19.44 | 20.46 | 21.44 | 22.57 | 23.62 |

No one at present (08)

| GSD1 | GSD2 | GSD3 | GSD4 | GSD5 | GSD6 |
|-------|-------|-------|-------|-------|-------|
| 19.44 | 20.46 | 21.44 | 22.57 | 23.62 | 24.59 |

Payroll & Benefits Manager (10)

Risk / Purchasing Manager

Grants Administrator / Accounts Receivable Accountant

| GSE1 | GSE2 | GSE3 | GSE4 | GSE5 | GSE6 |
|-------|-------|-------|-------|-------|-------|
| 20.46 | 21.44 | 22.57 | 23.62 | 24.59 | 26.09 |

No one at present (12)

| GSF1 | GSF2 | GSF3 | GSF4 | GSF5 | GSF6 |
|-------|-------|-------|-------|-------|-------|
| 21.44 | 22.57 | 23.62 | 24.59 | 26.09 | 27.39 |

Data Communications Supervisor (14)

Street Maintenance Supervisor

Park Maintenance Supervisor

Sewer Maintenance Supervisor

Traffic Maintenance Supervisor

Lab Supervisor

| GSG1 | GSG2 | GSG3 | GSG4 | GSG5 | GSG6 |
|-------|-------|-------|-------|-------|-------|
| 22.57 | 23.62 | 24.59 | 26.09 | 27.39 | 28.74 |

Recycling Coordinator (16)

Planner I

Zoning and Housing Coordinator

Garage Supervisor

| GSH1 | GSH2 | GSH3 | GSH4 | GSH5 | GSH6 |
|-------|-------|-------|-------|-------|-------|
| 23.62 | 24.59 | 26.09 | 27.39 | 28.74 | 30.17 |

| | | | | | | |
|---|--|-------|-------|-------|-------|-------|
| | Operations Supervisor (WPCF) (18) | | | | | |
| | Maintenance Supervisor (WPCF) | | | | | |
| | Airport Facilities Manager | | | | | |
| | Graphic Information System (GIS) Administrator | | | | | |
| | GSI1 | GSI2 | GSI3 | GSI4 | GSI5 | GSI6 |
| | 24.59 | 26.09 | 27.39 | 28.74 | 30.17 | 31.66 |
| | Accountant (20) | | | | | |
| | GSJ1 | GSJ2 | GSJ3 | GSJ4 | GSJ5 | GSJ6 |
| | 26.09 | 27.39 | 28.74 | 30.17 | 31.66 | 33.28 |
| ^ | Police Sergeant (21) | | | | | |
| | GSS1 | GSS2 | GSS3 | GSS4 | GSS5 | GSS6 |
| | 28.70 | 29.97 | 31.30 | 32.70 | 34.16 | 35.75 |
| | Engineering Supervisor (22) | | | | | |
| | GSK1 | GSK2 | GSK3 | GSK4 | GSK5 | GSK6 |
| | 27.39 | 28.74 | 30.17 | 31.66 | 33.28 | 34.92 |
| | Deputy Fire Chief (24) | | | | | |
| | GSL1 | GSL2 | GSL3 | GSL4 | GSL5 | GSL6 |
| | 28.74 | 30.17 | 31.66 | 33.28 | 34.92 | 36.68 |
| ^ | Police Lieutenant (25) | | | | | |
| | GST1 | GST2 | GST3 | GST4 | GST5 | GST6 |
| | 31.30 | 32.70 | 34.16 | 35.75 | 37.36 | 39.08 |
| | Public Works Operations Superintendent (26) | | | | | |
| | GSM1 | GSM2 | GSM3 | GSM4 | GSM5 | GSM6 |
| | 30.17 | 31.66 | 33.28 | 34.92 | 36.68 | 38.47 |
| ^ | City Engineer (30) | | | | | |
| | GSN1 | GSN2 | GSN3 | GSN4 | GSN5 | GSN6 |
| | 41.53 | 43.61 | 45.71 | 48.06 | 50.47 | 52.99 |
| ^ | Assistant City Engineer (28) | | | | | |
| | GSO1 | GSO2 | GSO3 | GSO4 | GSO5 | GSO6 |
| | 37.15 | 39.02 | 40.96 | 43.02 | 45.16 | 47.41 |
| ^ | Senior Planner (32) | | | | | |
| | GSP1 | GSP2 | GSP3 | GSP4 | GSP5 | GSP6 |
| | 37.17 | 39.04 | 40.98 | 43.02 | 45.19 | 47.44 |
| ^ | Information Technology Manager (34) | | | | | |
| | GSQ1 | GSQ2 | GSQ3 | GSQ4 | GSQ5 | GSQ6 |

| | | | | | |
|-------|-------|-------|-------|-------|-------|
| 35.55 | 37.31 | 39.18 | 41.15 | 43.20 | 45.37 |
|-------|-------|-------|-------|-------|-------|

| | | | | | |
|----------------------------|-------|-------|-------|-------|-------|
| ^ WPCF SUPERINTENDENT (36) | | | | | |
| GSR1 | GSR2 | GSR3 | GSR4 | GSR5 | GSR6 |
| 35.27 | 37.04 | 38.89 | 40.83 | 42.87 | 45.01 |

**Administrative Assistant is also currently an HR Coordinator. An additional \$5,000 per year in 2020 (\$2.40 per hour) was provided for the HR Coordinator responsibilities.

- 2021 2% COLA - \$2.45 an hour
- 2022 2% COLA - \$2.50 an hour

^ This will not be in line with other Pay Codes – It is not the 5% above previous pay grades.

FOREMAN PAY – additional \$2 an hour

PART-TIME EMPLOYEES

AIRPORT LINE TECHNICIAN (50)

| | |
|----------------|---------|
| Year 1: (ALT1) | \$13.00 |
| Year 2: (ALT2) | \$14.00 |
| Year 3: (ALT3) | \$15.00 |

SEASONAL/CONTRACTED EMPLOYEES

(This includes all departments with no exceptions unless approved by the City Administrator.)

STREETS, AIRPORT, PARKS, CEMETERY & WPCF MAINTENANCE, SEASONAL CODE ENFORCEMENT (SPW) (52):

| | |
|----------------|------------------|
| Year 1: (SPW1) | \$14.00 per hour |
| Year 2: (SPW2) | \$15.00 per hour |

BEACH EMPLOYEES:

Seasonal Aquatics Supervisor (SAS) (54):

| | |
|----------------|---------|
| Year 1: (SAS1) | \$12.00 |
| Year 2: (SAS2) | \$13.00 |
| Year 3: (SAS3) | \$14.00 |

Lifeguards: (58)

| | |
|---------------|---------|
| Year 1: (BL1) | \$11.00 |
| Year 2: (BL2) | \$11.50 |
| Year 3: (BL3) | \$12.00 |

Water Aerobics / Swim Instructors (60)

| | |
|-----------------|---------|
| Year 1: (WASI1) | \$11.00 |
| Year 2: (WASI2) | \$12.00 |
| Year 3: (WASI3) | \$13.00 |

| | |
|-------------------------|---------|
| Admissions: (BA1) (62) | \$10.00 |
| Concessions: (BC1) (64) | \$10.00 |

Evening Janitor/Seasonal Maintenance (66):

| | |
|----------------|--------|
| Year 1: (BME1) | \$9.50 |
| Year 2: (BME2) | \$9.75 |

Position Information

| | |
|---------------------------------------|----------------------------|
| Position Name | Assistant Library Director |
| Department Name | Library |
| Department Number | 410 |
| Position Open Date | — |
| Reason Position Open | — |
| Civil Service Position (Yes or No) | NO |

Change Requested

*Pay Grade - *Once City Administrator approves, this change must be approved by City Council.*

| | |
|--|---|
| Current Pay Grade | \$54,600 (\$26.25/hour) |
| Proposed Pay Grade | \$55,972.80 (\$26.91/hour) |
| Supporting Information | Library board approved - See attached minutes |
| Budget Amendment Needed – Yes or No | No |

Reporting Structure

| | |
|--|--|
| Current Direct Supervisor Title | |
| Proposed Direct Supervisor | |
| Supporting Information | |
| Budget Amendment Needed – Yes or No | |

Position Elimination – Provide Reason

| |
|--|
| |
|--|

Position Creation

| | |
|-------------------------------------|--|
| Supporting Information | |
| Budget Amendment Needed – Yes or No | |

Donna Sweet
Department Head

5/23/23
Date

Barbara Coe
HR Department

5/22/2023
Date

PJ
City Administrator

5/22/2023
Date

OTTUMWA PUBLIC LIBRARY
Board of Trustees
Minutes from the meeting held Monday, May 8, 2023

- I. President Joyce Kramer called the meeting of the Ottumwa Public Library Board of Trustees to order at 5:07 p.m. on Monday, May 8, 2023 in the meeting room of the Ottumwa Public Library, 102 W. Fourth Street, Ottumwa, IA 52501.
- II. The following Trustees were present and constitute the legal quorum necessary to transact business:
 - A. Joyce Kramer, President
 - B. LeAnn Lemberger, Secretary
 - C. Jo Rohach
 - D. Himar Hernandez

Michael Carpenter was absent.

Also in attendance was Ottumwa Public Library Director, Sonja Ferrell.
- III. LeAnn Lemberger made a motion to approve the Agenda as presented. Jo Rohach seconded the motion. The motion passed unanimously.
- IV. LeAnn Lemberger made a motion to approve the Minutes from 3/13/23. Jo Rohach seconded the motion. The motion passed unanimously.
- V. President Joyce Kramer made a motion to approve payment of the March 2023 Expenses and the April 2023 Expenses as presented. Jo Rohach seconded the motion. The motion passed unanimously.
- VI. **OLD BUSINESS:** None.
- VII. **NEW BUSINESS:**
 - I. Review / Revise Hotspot Policy: Sonja indicated that there has been a dramatic increase in hotspots not being returned in the last 6-9 months and was recommending updating the policy. She noted that the majority of those that had not been returned were checked out to new patrons. She recommended switching the requirement to a person with a card at least 180 days. The hotspots are the only library item that accrues fines. Jo Rohach made a suggestion that there should be some sort of collateral or deposit fee. It was decided that a \$10 Cash deposit be required (not paid by credit card). LeAnn Lemberger made a motion to amend and approve the Hotspot Policy. Jo Rohach seconded the motion. LeAnn Lemberger suggested that this be re-visited again in 90 days. Motion was approved unanimously.

2. Annual Director Evaluation:

Sonja presented a self-evaluation with the board members regarding this past year here at the Library and the changes and improvements involving the Library. After the evaluation conversation was completed she gave an overview of the process that was taking place across the city for city employees that participated in a job description and wages survey. The city is waiting on a report from the Gallagher company on comparing wages to other cities and private entities. At city wide employee meetings it was announced that no raises or contract re-openings would take place until this report was issued. Because of this Sonja asked that any discussion of a raise be delayed until that time. She did advocate that the assistant director of the library should receive a raise as it is typically discussed at the April or May board meeting. She noted that the library staff under contract were receiving a 2.5% step increase raise in this fiscal year on their date of hire anniversary and she suggested that the same percentage be applied to the Assistant Director position. LeAnn Lemberger motioned that Allyson Kirking-Russo (Assistant Director) receive a 2.5% pay raise effective as of today May 8, 2023 and that the Board re-visit the Director's wages in 90 days. Jo Rohach seconded the motion. It was approved unanimously.

VIII. DIRECTOR'S REPORT:

The Board and Sonja all gave positive feedback regarding the Board Training State Library employee Becky Heil gave to the board of trustees for the Wapello County public libraries.

The board welcomed Himar Hernandez as the newest OPL Board of Trustees member.

Gateway school students donated outdoor board games that they purchased with some Be the Light Grant money. On 5/23/2023 there will be a Family Game Night at the OPL to unveil the games for check out.

The new OPL website will be launched soon. It will be a quiet launch to work out the bugs before publicity is done on it.

A second round of Basic Computer classes are scheduled for May 18 & 25.

Allyson Kirking-Russo will be scheduling another Writing Class in the future.

DPIL (Dolly Parton Imagination Library) registration is at 724.

Reminisce Society (Date Change: Tuesday, 5/30/23) will be with Rich Tyler and Humanities Iowa, "Why Save an Old Barn".

The 11th Pages for Pennies 2023 was a huge success. Rough estimate of \$14,634 money raised. There were way more tables and definitely higher quality of books this year. Afterwards, there was 250 boxes of books for next year.

On March 27, Mediacom had shut down the Library's wi-fi without notifying the Library, due to a patron (inside the Library) who was illegally downloading materials. Sonja & Doug were able to determine a method to proceed which Mediacom agreed with in order to turn the Wi-fi back on.

On 5/17/23 (Wednesday) there will be a concert by Forrest McCurren.

A group of Walsh High School alumni have donated to the Ottumwa Public Library a park bench to be installed beside the OHS bulldog statue.

Sonja informed the board members that there are so far, 9 children programs scheduled for the Summer Reading Program 2023.

Jo Rohach made a motion to adjourn. LeAnn Lemberger seconded the motion. The motion was passed unanimously. President Joyce Kramer adjourned the meeting at 6:00 pm.

Respectfully submitted,

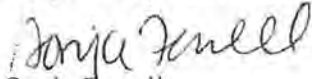

Sonja Ferrell
Director
Ottumwa Public Library

SF

cc: file

Attachments

received
6-8-23 715A

Item No. B.-5

681 207

CITY OF OTTUMWA Staff Summary

**** ACTION ITEM ****

Council Meeting of: Jun 20, 2023

Christina Reinhard *cjr*
Prepared By

Administration
Department

Department Head

Rp At
City Administrator Approval

AGENDA TITLE: Resolution No. 97-2023 - Resolution approving the Wapello County /
City of Ottumwa Law Enforcement Center Maintenance Budget for the
Fiscal Year Ending June 30, 2024.

Public hearing required if this box is checked.

RECOMMENDATION: Pass and adopt Resolution No. 97-2023.

DISCUSSION: It is required by the Joint Law Enforcement Center (JLEC) Agreement for the Police Chief, County Sheriff, County Auditor, and City Director of Finance to develop a budget and the agreement for both County Board of Supervisors and City Council Approval. The Maintenance Fund is maintained by the Wapello County Auditor, who has provided the estimates for the budget.

Source of Funds: N/A

Budgeted Item: Budget Amendment Needed: No

RESOLUTION NO. 97-2023

A RESOLUTION APPROVING THE WAPELLO COUNTY / CITY OF OTTUMWA LAW ENFORCEMENT CENTER MAINTENANCE BUDGET FOR THE FISCAL YEAR ENDING JUNE 30, 2024.

WHEREAS, the City of Ottumwa and Wapello County jointly occupy a facility known as the Law Enforcement Center; and

WHEREAS, the City of Ottumwa and Wapello County have entered into a Joint Law Enforcement Center Agreement regarding facility maintenance; and

WHEREAS, an annual budget has been prepared and forwarded to the City for consideration.

NOW, THEREFORE, BE IT RESOLVED, BY THE CITY COUNCIL OF THE CITY OF OTTUMWA, IOWA THAT:

The annual budget for the fiscal year ending June 30, 2024 as set forth in the attached summary is hereby approved and the Mayor is authorized to execute on behalf of the City of Ottumwa.

APPROVED, PASSED, AND ADOPTED, this 20th day of June, 2023.

CITY OF OTTUMWA, IOWA

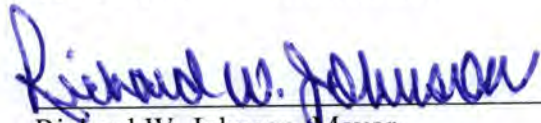
Richard W. Johnson, Mayor

ATTEST:

Christina Reinhard, City Clerk

2023-2024 WAPELLO COUNTY/CITY OF OTTUMWA LAW ENFORCEMENT CENTER MAINTENANCE BUDGET

FUND 15 - DEPARTMENT 14

| RESOURCES: BEGINNING FUND BALANCES and INCOME | LINE | (A) Actual Fiscal Year Beginning July 1, 2021 | (B) Re-Estimated Fiscal Year Beginning July 1, 2022 | (C) Fiscal Year Beginning July 1, 2023 | REQUIREMENTS: EXPENDITURES AND ENDING FUND BALANCE | LINE | (A) Actual Fiscal Year Ending June 30, 2022 | (B) Re-Estimated Fiscal Year Ending June 30, 2023 | (C) Fiscal Year Ending June 30, 2024 |
|---|------|--|---|---|--|------|--|---|---|
| | 1 | | | | | 1 | | | |
| | 2 | | | | | 2 | | | |
| | 3 | | | | 430-Natural Gas | 3 | | | |
| | 4 | | | | 431-Electric Power | 4 | | | |
| | 5 | | | | 432-Water | 5 | | | |
| | 6 | | | | | 6 | | | |
| COUNTY SHARE PER SQ. FT.(D) | 7 | | | | 441--Building Repair/Maint | 7 | 4,784 | 5,595 | 8,000 |
| CITY SHARE PER SQ. FT.(D) | 8 | | | | 442-Fixed Plant Equipment | 8 | 44,956 | 42,805 | 45,000 |
| COUNTY SHARE MISC (8) | 9 | | | | 445--Plumbing Equipment | 9 | 30,524 | 39,240 | 20,000 |
| CITY SHARE MISC (8) | 10 | | | 7,687 | 462--Real Property Insurance | 10 | 14,401 | 16,898 | 18,000 |
| EXCESS FROM HOUSING (B)(line 26) | 11 | 10,489 | 4,440 | 10,000 | Inter-Fund Transfer | 11 | | | |
| INTEREST EARNED ON FUND (C) | 12 | 368 | 12,459 | 2,500 | | 12 | | | |
| OTHER (LIST) | 13 | | | | Major Repairs | 13 | | | |
| Local Option Tax | 14 | | | | 610--Building-Roofs | 14 | 434,298 | 95,260 | 45,000 |
| Refunds | 15 | | | | 611--Air Conditioning | 15 | | | |
| Miscellaneous | 16 | | | 23,236 | 612--Major Heating | 16 | | | |
| Inter-Fund Transfer | 17 | | | | 613--Major Plumbing | 17 | | | |
| | 18 | | | | | 18 | | | |
| | 19 | | | | | 19 | | | |
| | 20 | | | | | 20 | | | |
| Sub-Total Other Receipts | 21 | 10,857 | 16,899 | 43,423 | Sub-Total Expenditures | 21 | 528,963 | 199,798 | 136,000 |
| BEGINNING FUND BALANCE AND OTHER RECEIPTS | 22 | 1,174,183 | 656,077 | 258,177 | ENDING FUND BALANCE | 22 | 528,963 | 408,500 | 136,000 |
| | 23 | | | | | 23 | | | |
| | 24 | | | | | 24 | | | |
| TOTAL RESOURCES | 25 | 1,185,040 | 666,677 | 301,600 | TOTAL REQUIREMENTS | 25 | 1,185,040 | 666,677 | 301,600 |

Signed 
Chair, Board of Supervisors

Date 5-16-2023

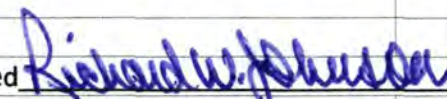
Signed 
Mayor, City of Ottumwa

Date 6/20/23

received
6823 715A

6/20/23

CITY OF OTTUMWA

Staff Summary

**** ACTION ITEM ****

Council Meeting of: Jun 20, 2023

Christina Reinhard

Prepared By

Christina Reinhard

Department Head

City Clerk

Department

City Administrator Approval

AGENDA TITLE: Resolution No. 98-2023, authorizing the destruction of certain records according to the Code of Iowa 2017, as amended, and the Record Retention Manual for Iowa Cities.

Public hearing required if this box is checked.

RECOMMENDATION: Pass and adopt Resolution No. 98-2023.

DISCUSSION: According to the Code of Iowa 2017, as amended, and the Record Retention Manual for Iowa Cities, certain records need to be kept for five (5) years or for a designated retention period based on administrative, legal and fiscal values. The attached list of records are over the required retention period as adopted and are no longer deemed necessary to retain for permanent record.

Source of Funds: N/A

Budgeted Item:

Budget Amendment Needed: No

RESOLUTION NO. 98-2023

RESOLUTION AUTHORIZING DESTRUCTION OF CERTAIN RECORDS
ACCORDING TO THE CODE OF IOWA, 2017, AS AMENDED

WHEREAS, the Code of Iowa, 2017, as amended, allows for the destruction of certain city records that are over five years in age;

WHEREAS, all financial documents have been audited and the following records are over five years in age and no longer deemed necessary to be retained, and have served their usefulness:

Regular bank statements and checks July 1, 2017 thru June 30, 2018;
Payroll bank statements and checks July 1, 2017 thru June 30, 2018;
Payroll input and time sheets for fiscal year 2017-2018;
Accounts payable invoices for fiscal year 2017-2018;
Accounts receivable receipts for fiscal years 2017-2018
Journal Vouchers for fiscal year 2017-2018;
Budget detail sheets for fiscal year 2015-2016;
City Clerk's Office receipts for fiscal year 2017-2018;
Affidavits of publication of council minutes, expenditures, notice to bidders, public hearing notices, budget estimates, budget amendments, annual financial reports for calendar year 2018;
City Clerk's copy of camping fee receipts, Building, Sign, Electrical, Heating and Plumbing permits, cigarette permits, dog licenses, and all other city license stubs and register for fiscal year 2017-2018;
Beer/liquor applications for establishments that have been out of business over five years;
Expired miscellaneous certificates of insurance over five years in age.

NOW THEREFORE, BE IT RESOLVED BY THE CITY COUNCIL OF THE CITY OF OTTUMWA, IOWA:

That the aforementioned documents be destroyed under the direction of the City Clerk and Finance Accountant, in accordance with state law and the Record Retention Manual for Iowa Cities as adopted by the City Council on January 16, 2007; and

PASSED, ADOPTED and APPROVED this 20th day of June, 2023.

CITY OF OTTUMWA, IOWA

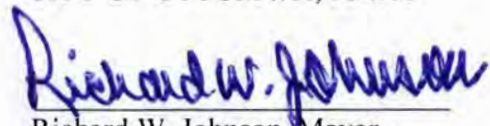
Richard W. Johnson, Mayor

ATTEST:

Christina Reinhard, City Clerk

| CITY NUMBER | BUSINESS LOCATION NAME | BUSINESS LOCATION ADDRESS | OWNERSHIP TYPE | LEGAL OWNER NAME | LEGAL OWNER MAILING ADDRESS | CITY STATE ZIP |
|-------------|--|---------------------------|----------------|-----------------------------|------------------------------------|---------------------------|
| 2135-2024 | Casey's General Store #2208 | 1603 W. Second | Corporation | Casey's Marketing Company | P.O. Box 3001 | Ankeny, IA 50021-8045 |
| 2136-2024 | Casey's General Store #1886 | 504 W. Mary | Corporation | Casey's Marketing Company | P.O. Box 3001 | Ankeny, IA 50021-8045 |
| 2137-2024 | Casey's General Store #1678 | 346 Richmond Ave. | Corporation | Casey's Marketing Company | P.O. Box 3001 | Ankeny, IA 50021-8045 |
| 2138-2024 | Casey's General Store #7 | 1001 E. Main | Corporation | Casey's Marketing Company | P.O. Box 3001 | Ankeny, IA 50021-8045 |
| 2160-2024 | BP | 1340 Albia Road | Corporation | Elliott Oil Company | P.O. Box 473 | Ottumwa, IA 52501 |
| 2161-2024 | BP | 1301 N. Court | Corporation | Elliott Oil Company | P.O. Box 473 | Ottumwa, IA 52501 |
| 2162-2024 | BP | 1147 N. Jefferson | Corporation | Elliott Oil Company | P.O. Box 473 | Ottumwa, IA 52501 |
| 2163-2024 | BP | 720 Richmond | Corporation | Elliott Oil Company | P.O. Box 473 | Ottumwa, IA 52501 |
| 2164-2024 | BP | 1049 W. Second | Corporation | Elliott Oil Company | P.O. Box 473 | Ottumwa, IA 52501 |
| 2187-2024 | Fareway Stores, Inc. #648 | 1325 Albia Rd. | Corporation | Fareway Stores, Inc. | P.O. Box 70 | Boone, IA 50036 |
| 2203-2024 | Smokin Hot | 2604 N. Court, Suite A. | LLC | Smokin Hot LLC | 2604 N. Court, Suite A | Ottumwa, IA 52501 |
| 2228-2024 | Yesway #1012 | 2508 N. Court St. | LLC | BW Gas & Convenience Retail | 138 Conant St. | Beverly, MA 01015 |
| 2229-2024 | Yesway #1013 | 534 Church St. | LLC | BW Gas & Convenience Retail | 138 Conant St. | Beverly, MA 01015 |
| 2230-2024 | Yesway #1014 | 502 W. Second | LLC | BW Gas & Convenience Retail | 138 Conant St. | Beverly, MA 01015 |
| 2231-2024 | Yesway #1030 | 1317 E. Mary | LLC | BW Gas & Convenience Retail | 138 Conant St. | Beverly, MA 01015 |
| 2239-2024 | Walgreens #1301 | 327 W. Fourth St | Corporation | Walgreen Co. | P.O. Box 901 | Deerfield, IL 60015 |
| 2243-2024 | Dollar General #7179 | 721 N. Quincy Ave. | Corporation | Dolgencorp, LLC | Attn: Licensing, 100 Mission Ridge | Goodlettsville, TN 37072 |
| 2245-2024 | Dollar General #2898 | 921 E. Main St | Corporation | Dolgencorp, LLC | Attn: Licensing, 100 Mission Ridge | Goodlettsville, TN 37072 |
| 2250-2024 | Smokin' Joe's Tobacco and Liquor Outlet #5 | 115 Albia Rd. | Corporation | The Outlet, Inc. | 1916 N. Sturdevant St. | Davenport, IA 52804 |
| 2251-2024 | Walmart #1285 | 1940 Venture Dr. | Corporation | Walmart Inc. | 508 SW 8th Street | Bentonville, AR 72716 |
| 2252-2024 | Fine Liquor & Tobacco | 821 B Albia Rd. | LLC | 3 Star Food, LLC | 821 B Albia Rd. | Ottumwa, IA 52501 |
| 2253-2024 | Iowa Liquor & Tobacco | 1021 E. Main St. | LLC | All Star Food, LLC | 1021 E. Main St. | Ottumwa, IA 52501 |
| 2256-2024 | Hy-Vee Food Store #1 | 1025 N. Quincy | Corporation | Hy-Vee, Inc. | 5820 Westown Parkway | West Des Moines, IA 50266 |
| 2257-2024 | Hy-Vee Fast & Fresh #1 | 1027 N. Quincy | Corporation | Hy-Vee, Inc. | 5820 Westown Parkway | West Des Moines, IA 50266 |
| 2258-2024 | Hy-Vee Food Store #2 | 2453 N. Court | Corporation | Hy-Vee, Inc. | 5820 Westown Parkway | West Des Moines, IA 50266 |
| 2259-2024 | Hy-Vee Fast & Fresh #2 | 2457 N. Court St. | Corporation | Hy-Vee, Inc. | 5820 Westown Parkway | West Des Moines, IA 50266 |
| 2260-2024 | Hy-Vee Drugstore | 1140 N. Jefferson St. | Corporation | Hy-Vee, Inc. | 5820 Westown Parkway | West Des Moines, IA 50266 |
| 2341-2024 | MAD Ave Quik Shop | 405 S. Madison Ave. | LLC | MAD JuStus LLC | 233 W. Alta Vista Ave. | Ottumwa, IA 52501 |
| 2342-2024 | Murphy USA #6945 | 1939 Venture Dr. | Corporation | Murphy Oil USA, Inc. | Attn: Permits, P.O. Box 7300 | El Dorado, AR 71731 |
| 4144-2024 | Ross Tobacco Shop LLC | 129 E. Second St. | LLC | Ramzy Abdel-Gadir | 2101 Forrest Ave | Des Moines, IA 50311 |
| 4903-2024 | Dollar General #24713 | 1235 Hutchinson Ave. | LLC | Dolgencorp, LLC | Attn: Licensing, 100 Mission Ridge | Goodlettsville, TN 37072 |

received
6-13-23 1145A

Item No. F.-1

6-13-23

CITY OF OTTUMWA

Staff Summary

**** ACTION ITEM ****

Council Meeting of : Jun 20, 2023

Jake Rusch

Prepared By

Zach Simonson

Department Head

Planning & Development

Department



City Administrator Approval

AGENDA TITLE: Resolution No. 90-2023, a resolution accepting the bid and approving the sale of 1531 Mable to Alissa Welch for the sum of \$300.00



****Public hearing required if this box is checked.****



The Proof of Publication for each Public Hearing must be attached to this Staff Summary. If the Proof of Publication is not attached, the item will not be placed on the agenda.

RECOMMENDATION: Pass and adopt Resolution No. 90-2023

DISCUSSION: The City accepted bids on this property until 2:00 PM May 11, 2023. One bid was submitted. Alissa Welch submitted the best bid in the amount of \$300.00 and staff recommends accepting the bid. A copy of the bid and a bid tab is attached.

Source of Funds: 151-3-342-6499

Budgeted Item:

Budget Amendment Needed:

RESOLUTION No. 90 - 2023

A RESOLUTION ACCEPTING THE BID AND APPROVING THE SALE OF CITY OWNED PROPERTY LOCATED AT 1531 MABLE TO ALISSA WELCH FOR THE SUM OF \$300.00

WHEREAS, the City of Ottumwa, is the present title holder to the property legally described as MANNING'S 1ST ADD LOT 16 BLK 1 City of Ottumwa, Wapello County, Iowa, also known as 1531 Mable Street; and

WHEREAS, pursuant to Resolution No. 89 – 2023 approved, passed and adopted May 16, 2023 the City Council authorized and directed the City Clerk to publish notice regarding the sale of said property to the successful bidder; and

WHEREAS, the City accepted sealed bids for the above mentioned property; and

WHEREAS, the City received one bid; and

WHEREAS, Alissa Welch submitted the best bid in the amount of \$300.00; and

WHEREAS, the property will be transferred by quit claim deed, with no abstract, and the buyer shall pay all costs associated with the conveyance of the property including any property taxes owed; and

WHEREAS, the buyer will Build a storage building on the property in conformance with applicable City Codes.

NOW, THEREFORE, BE IT RESOLVED BY THE CITY COUNCIL OF THE CITY OF OTTUMWA, IOWA, that the bid received from Alissa Welch, in the amount of \$300.00 be and it is hereby accepted and the sale of said property is approved and the Mayor and City Clerk are hereby authorized to sign the appropriate deed on behalf of the city conveying said property.

PASSED AND ADOPTED this 20th day of June 2023.

City of Ottumwa, Iowa

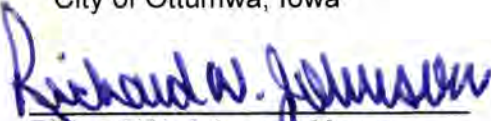
Richard W. Johnson, Mayor

ATTEST:



Christina Reinhard, City Clerk

**PURCHASE AGREEMENT BID FORM
FOR
1531 MABLE
STREET, OTTUMWA, IOWA**

This proposal is for a City owned property located at **MANNING'S 1ST ADD LOT 16 BLK 1 (1531 MABLE) City of Ottumwa, Wapello County, Iowa** legally known as 1531 Mable Street. The property is located in an I-1 Limited Industrial zoning district and must be used in that regard.

The property is offered for sale subject to the following conditions:

A bid security in the form of a certified check or cash in the amount of 10% of the bid price is required to be submitted with the proposal. The property will be transferred by **Quit Claim Deed with no abstract** and the buyer will pay the costs of conveyance as well as any property taxes owed.

It is understood that the City of Ottumwa reserves the right to accept or reject any or all proposals, to disregard any formality in connection therewith, or to accept any proposal which in its opinion is in the best interest of the City.

Bidders also understand that the costs of conveyance (publishing the public hearing notice, recording fees and preparation of the deed) and any property taxes owed are costs that are in addition to the total purchase price offered for the property.

It is understood and agreed that a Purchase Agreement Form, once submitted and opened, cannot be withdrawn without the consent of the City of Ottumwa.

\$ 300⁰⁰

TOTAL PURCHASE PRICE OFFERED FOR THIS PROPERTY

If my proposal is accepted, I the undersigned further agree to keep the property free of any and all nuisances and to keep the grass cut below 10" in height.

ALISSA WELCH

515-494-0440

NAME OF BIDDER (PRINTED)

TELEPHONE NUMBER

WE WANT TO BUY AND TAKE
DOWN ADJOINING PROPERTY AND
BUILD A LARGE BUILDING

Alissa Welch

MAILING ADDRESS

SIGNATURE

22481 230th St. DALLAS Center IA. 50063

ALISSAWELCH94@MAIL.COM

DATE MAY 11th 2023

EMAIL ADDRESS

OR IF CANT BUY THE OTHER BUILDINGS,
WE WILL BUILD STORAGE BUILDING.

PROOF OF PUBLICATION

STATE OF IOWA
WAPELLO COUNTY

I, Kyle Ocker, being duly sworn on my oath, say I am the General Manager of the Ottumwa Courier, a newspaper printed in said Wapello County, Iowa and of general circulation there in, and that the advertisement

Public Hearing
City of Ottumwa

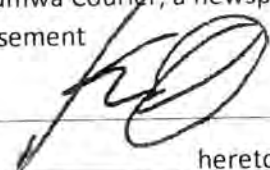

hereto attached

was published in said newspaper for 1 consecutive week's to-wit: 6/15/23

Subscribed and sworn to before me, and in my presence, by the said 15th day of June, 2023



Notary Public

In and for Wapello County



Printer's fee \$16.44

COPY OF ADVERTISEMENT

NOTICE OF PUBLIC HEARING
TO WHOM IT MAY CONCERN:
Notice is hereby given that the City Council of the City of Ottumwa, Iowa, will hold a public hearing Tuesday, June 20, 2023 at 5:30 P.M. in City Hall in the City of Ottumwa, Iowa on its intent to dispose of real property legally described as MANNING'S 1ST ADD LOT 16 BLK 1 City of Ottumwa, Wapello County, Iowa, also known as 1531 Mable Street to the successful bidder by quit claim deed, with no abstract and the buyer paying all costs of conveyance. All persons interested in the intent to dispose of said property are invited to be present at the above time and place on the date mentioned to present their objections to, or arguments for the intent to dispose of said property. FOR THE CITY OF OTTUMWA: Jake Rusch, Zoning and Housing Coordinator

received
6-19-23 10A

forwarded

CITY OF OTTUMWA
Staff Summary

**** ACTION ITEM ****

Council Meeting of : Jun 20, 2023

Planning & Development
Department

Zach Simonson
Prepared By
Zach Simonson
Department Head



City Administrator Approval

AGENDA TITLE: ORDINANCE NO. 3212-2023 - AN ORDINANCE ESTABLISHING SOLID WASTE FEES FOR NONCOMMERCIAL ESTABLISHMENTS BY REPEALING AND REPLACING SECTION 31½-35 OF THE MUNICIPAL CODE OF THE CITY OF OTTUMWA, WAPELLO COUNTY, IOWA.

Public hearing required if this box is checked.

RECOMMENDATION: Pass second consideration, waive third consideration and pass and adopt Ordinance No. 3212-2023.

DISCUSSION: This ordinance adopts new solid waste fees for noncommercial establishment customers. The current ordinance expires July 1, 2023. The new fees include an increase of \$2.82 per month or 14.7%. The increase accounts for the increase in the landfill tipping fee, the contract increase for Bridge City Sanitation, the fuel surcharge paid to Bridge City Sanitation and administrative costs. Without any change, this ordinance would

Source of Funds:

Budgeted Item: Budget Amendment Needed:

increase the fee again by \$1.00 per month on July 1, 2024. The 2024 increase would be 4.5%. For FY 2023-2024 each customer would pay \$264 per year for trash collection, up from \$230.16 today. In FY 2024-2025 that cost would increase to \$276 per year.

Trash collection fees are collected by the Ottumwa Water Works and the City pays Ottumwa Water Works an administrative fee for processing these payments.

Because there was no meeting on June 6, 2023, Staff recommends waiving the third consideration in order to pass and adopt the fee increase before the July 1 effective date.

ORDINANCE NO. 3212-2023

AN ORDINANCE ESTABLISHING SOLID WASTE FEES FOR NONCOMMERCIAL ESTABLISHMENTS BY REPEALING AND REPLACING SECTION 31½-35 OF THE MUNICIPAL CODE OF THE CITY OF OTTUMWA, WAPELLO COUNTY, IOWA.

NOW, THEREFORE, BE IT ORDAINED BY THE CITY COUNCIL OF THE CITY OF OTTUMWA, IOWA, THAT:

SECTION ONE

Section 31½-35 of the municipal code of the City of Ottumwa is hereby amended by repealing Section 31½-35 in its entirety and enacting the following in lieu thereof:

Sec. 31½-35. – Solid waste fees for noncommercial establishment customers.

- (a) Solid waste fees are mandatory for all single-family dwellings and other dwellings containing four units or less. This shall not apply to mobile home parks wherein water service is metered by one meter for the mobile home park, places of worship, or multi-family dwellings containing more than four dwelling units. Dwelling units housed with a commercial and/or business building shall also be exempt providing there is a written agreement between the tenant and business landlord that the commercial or business building owner or occupant will provide weekly solid waste disposal from a city licensed hauler. Any of the above referenced exceptions may subscribe to the city's solid waste collection services if the contractor agrees to provide service. The mandatory monthly collection rates are hereby established for garbage, refuse, recyclables and bulk items per residence for 64 gallons of refuse, in a cart provided by the contractor for curbside customers or two 32-gallon bags, provided by the customer, for walk up customers, one bulky item and recyclables in the provided bin for the following rates:

July 1, 2023 through June 30, 2024: \$22.00 per unit per month

July 1, 2024 through June 30, 2025: \$23.00 per unit per month

- (1) Additional 32-gallons or less bags with properly attached city stickers costing \$1.00 each will be collected. Bags without these stickers will not be collected. Rates for yard waste bag stickers will be \$1.00 each.
- (2) Residents qualifying for Southern Iowa Economic Development Association (S.I.E.D.A.) Energy Assistance Program are allowed to pay a reduced rate of \$2.00 per month lower than the rates listed above (e.g. \$20.00).
- (b) The Ottumwa Water and Hydro shall collect noncommercial establishment solid waste fees, as established in this section, as a part of the monthly water bill for the applicable customer.
- (c) The city shall direct bill those noncommercial establishment customers that are not billed by the Ottumwa Water and Hydro for water service.

SECTION TWO. Severability. If any section, subsection, sentence, clause, phrase or portion of this ordinance be held invalid or unconstitutional by any court of competent jurisdiction, such portion shall be deemed a separate, distinct and independent provision, and such holding shall not affect the validity of the remaining portion hereof.

SECTION THREE. Repealer. All ordinances or parts of ordinances in conflict with the provisions of this ordinance are hereby repealed.

SECTION FOUR. This ordinance shall be in full force and effect, from and after its passage, adoption, and approval and publication as required by law, unless a subsequent effective date is set out hereinabove.

SECTION FIVE. When this ordinance is in effect, it shall automatically supplement, amend, and become a part of the said Code of Ordinance (Municipal Code) of the City of Ottumwa, Iowa.

PASSED on its first consideration the 16th day of May, 2023.

PASSED on its second consideration the 20th day of June, 2023.

Requirement of consideration and vote at two (2) prior Council meetings suspended the _____ day of WAIVED, 2023.

APPROVED this 20th day of June, 2023.

CITY OF OTTUMWA, IOWA

By: Richard W. Johnson
Richard W. Johnson, Mayor

_____ No action taken by Mayor.

_____ Vetoed this _____ day of _____, 2023

Richard W. Johnson, Mayor

_____ Repassed and adopted over the veto this _____ day of _____, 2023.

_____ Veto affirmed this _____ day of _____, 2023 by failure of vote taken to repass.

_____ Veto affirmed no timely vote taken to repass over veto.

ATTEST:

Chris Reinhard
Chris Reinhard, City Clerk

received
6-14-23 430p

CITY OF OTTUMWA Staff Summary

**** ACTION ITEM ****

Council Meeting of: Jun 20, 2023

Planning & Development
Department

Zach Simonson

Prepared By

Zach Simonson

Department Head

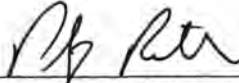

City Administrator Approval

AGENDA TITLE: ORDINANCE NO. 3213-2023: AN ORDINANCE AMENDING THE CODE OF ORDINANCES (MUNICIPAL CODE OF THE CITY OF OTTUMWA, IOWA) BY CHANGING THE ZONING CLASSIFICATION OF PROPERTY KNOWN AS 526 E SECOND FROM R-4 TO C-2 IN THE CITY OF OTTUMWA, WAPELLO COUNTY, IOWA

Public hearing required if this box is checked.

RECOMMENDATION: Plan and Zoning Commission recommends to pass third consideration and pass and adopt Ordinance No. 3213-2023.

DISCUSSION: The applicant, Ottumwa Community School District, seeks rezoning the property at 526 E Second in order to complete an athletics complex. The parcel is currently used as a parking lot. The parking use is existing non-conforming and not typically a permitted use in the current R-4 district. The change of use would alleviate the existing non-conforming issue and allow for the athletics complex use.

Source of Funds:

Budgeted Item:

Budget Amendment Needed:

Section 38-966 requires reviewing the following elements in order to consider a rezoning:

1. Conformance to Future Land Use Plan: The Future Land Use Plan identifies 526 E Second as suitable for Public, Semi-Public and Institutional Use. The athletics complex use is consistent with that determination. The Land Use and Zoning Compatibility Matrix does not identify any Commercial Zoning Districts as Compatible or Partially Compatible with Public, Semi-Public or Institutional Use. Staff believes this should be corrected as numerous Public-Semi-Public and Institutional Uses are permitted by right or conditional use permit in a wide variety of zoning districts and many such uses are conducted in zoning districts including R-2, R-4, C-1, C-2, C-4 and I-1. Staff staff has prepared Amendment 3 to the Comprehensive Plan to update the matrix to make this correction. Amendment 3 is set for public hearing and adoption May 16.
2. Conformance to goals and objectives of the Comprehensive Plan: The athletics complex would advance at least two goals in the 2040 Our Ottumwa Comprehensive Plan:
 - a. Quality of Life 2b: Expand recreational activities for the entire community including indoor and outdoor winter activities and after school programs. The athletics complex will provide improved facilities for student recreation.
 - b. Growth 1a: Seek out opportunities for advancing Ottumwa's economic leadership role. The facility will improve Ottumwa's position as destination for sports tourism in the region.
3. Compatibility with surrounding development: The bulk of surrounding development is the rest of the Ottumwa High School campus. Other surrounding development has a commercial nature.
4. Potential hardships or nuisances for surrounding development: Current use is consistent with traffic generation, large amounts of foot traffic, etc.
5. Public utilities: Development will be served by existing utilities.
6. Trend of development: The trend of the development in this area supports the rezoning. The OHS campus has grown and added new parking the west.

ORDINANCE NO. 3213-2023

AN ORDINANCE AMENDING THE CODE OF ORDINANCES (MUNICIPAL CODE OF THE CITY OF OTTUMWA, IOWA) BY CHANGING THE ZONING CLASSIFICATION OF PROPERTY KNOWN AS 526 E SECOND FROM R-4 TO C-2 IN THE CITY OF OTTUMWA, WAPELLO COUNTY, IOWA

NOW, THEREFORE, BE IT ORDAINED BY THE CITY COUNCIL OF THE CITY OF OTTUMWA, IOWA, THAT:

SECTION 1

Zoning Ordinance #3105-2015 of the City of Ottumwa, Iowa, as amended and as set forth in Chapter 38 of the Municipal Code, City of Ottumwa, Iowa be and the same is hereby amended and changed to conform with this ordinance and the following described property, to wit:

Ottumwa Original Lots 263-268 Blk 19. As recorded in book 439 page 305.

Described area contains 1.21 acres and is subject to easements and other restrictions of record.

Be and the same is hereby changed from its present zoning classification of "R-4" Multifamily Residential District (Medium Density) to "C-2" Community Commercial District.

SECTION 2

The official zoning map of the City of Ottumwa, Iowa duly designated as such, and on file in the office of the City Clerk and the Wapello County Recorder, is hereby amended and changed to conform to this ordinance and the City Clerk, pursuant to Section 38-30 of the Zoning Ordinance #3088-2015, as amended, is hereby directed to record a certified copy of this said ordinance with the Wapello County Recorder and attach a certified copy of this said ordinance to the official zoning map.

SECTION 3

This ordinance shall be in full force and effect, from and after its passage, adoption and approval and publication as required by law, unless a subsequent effective date is set out hereinabove.

SECTION 4

When this ordinance is in effect, it shall automatically supplement, amend and become a part of the said Code of Ordinance (Municipal Code) of the City of Ottumwa, Iowa.

Passed on its first consideration on the 2nd day of May, 2023.

Passed on its second consideration on the 16th day of May, 2023.

Requirement of consideration and vote at two prior council meetings suspended on the ____ day of _____, 2023.

Final passage and adoption on the 20th day of June, 2023.

CITY OF OTTUMWA, IOWA

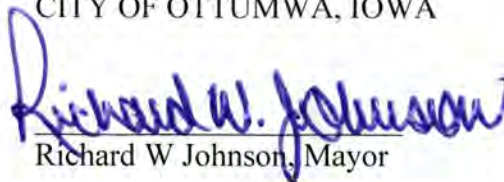
Richard W Johnson, Mayor

No action taken by Mayor.

Vetoed this ____ day of _____, 2023.

Richard W Johnson, Mayor

Repassed and adopted over the veto this ____ day of _____, 2023.

Veto affirmed this ____ day of _____, 2023 by failure of vote taken to repass.

Veto affirmed, no timely vote taken to repass over veto.

ATTEST:



Chris Reinhard, City Clerk



| APPLICATION TO REZONE PROPERTY | | |
|---|----------------|-----------------|
| APPLICANT INFORMATION | | |
| Name: LANDON ALLEN | | |
| Phone: 641-683-4449 | | |
| Address: 1112 North Van Buren | | |
| City: Ottumwa | State: IA | ZIP Code: 52501 |
| E-mail: landon.allen@ottumwaschool.com | | |
| PROPERTY INFORMATION | | |
| Business Name: Ottumwa School District | | |
| Proposed Property Use: High School Athletics Complex | | |
| | | |
| Property Manager (If different from applicant): same | | |
| Address: | | |
| City: | State: | ZIP Code: |
| E-mail: | | |
| REZONE INFORMATION | | |
| Current Zoning Classification R-4 | | |
| Requested Zoning Classification C-2 | | |
| SIGNATURES | | |
| I authorize the verification of the information provided on this form and have attached all required documentation. | | |
| Signature of applicant: <i>Landon V. Allen</i> | Date: 4/3/2023 | |

Submittal Checklist

- Full Legal Description(Deed)
- List of all property owners within 200 feet radius of property
- Letter to the Plan Commission "Why you want the property rezoned"
- Application fee(Non-refundable) \$300.00
- Site Plan

Hearings by city planning and zoning commission on proposed amendments, report to city council; hearings by city council. All applications for amendment of the ordinance shall first be submitted to the city planning and zoning commission, who will hold a public hearing in relation to the proposed amendment. At the public hearing, citizens shall have an opportunity to be heard. The planning and zoning commission shall then make a recommendation to the city council. The city council may adopt, reject, or send back to the planning and zoning commission's recommendation after a public hearing before the city council. The planning and zoning commission and city council shall find that the project adequately addresses the following concerns:

- (1) The rezoning conforms to the future land use map in the comprehensive plan.
- (2) The proposed rezoning is consistent with the goals and objectives of the comprehensive plan.

If the responses for both subsections (1) and (2) are not affirmative, then either the rezoning request recommendation must be denial or the planning and zoning commission and city council must amend the comprehensive plan to provide the required consistency.

- (3) The subject property, after the requested rezoning, will be compatible with the character of the surrounding neighborhood, including the existing uses and zoning of the properties near the subject property.
- (4) The potential hardships and nuisances (such as noise, neon lights, odors, etc.) of the rezoning request have been adequately considered.
- (5) There are adequate public utilities and services available to the land if rezoned. If not, who will have to pay for installing them?
- (6) The trend of development near the subject property, including changes that have taken place in the area since the subject property was placed in its current zoning district, supports the rezoning request.
- (7) The proposed rezoning amendment is in the public interest and not solely in the interests of the applicant.

Summary

Zoning is a tool used to classify and regulate the uses that occur on land within the city. Zoning takes into account past uses but it also is used as a tool to guide future development in a way that makes sense for the community and is outlined in the Comprehensive Plan.

To change a land use classification, or propose a "rezone," The applicant must have a "good reason" or one that is substantiated by the Comprehensive Plan or other planning document that outlines the need for the area of proposed rezone. Staff can help the applicant read the documents to identify if there is a need.

If the applicant decides to apply for a rezone, they must attach all required documentation, submit the fee, and the process can begin.

Process

The applicant will complete the application, and staff will begin processing it. The application must have a published notice in the paper, and the applicant must place a sign

in the yard of the property that is proposed to be rezoned. This may be obtained from the Planning Department. We will also mail a letter to adjacent property owners within a 200 foot radius of the parcel(s) to be rezoned. The application will then be presented to the Planning and Zoning Commission. We need a minimum of 45 days prior to the Planning and Zoning Commission meeting to process the application properly. The applicant must appear at the Planning and Zoning Commission meeting to present and or answer questions asked by the adjacent property owners or the board. If you wish to bring speakers that are in favor of the rezone, it is encouraged.

After a recommendation is given by the Planning and Zoning Commission, it will move up and be presented to the City Council for three readings. The first reading includes a public hearing and it is recommended that the applicant attend the first reading to answer questions that the City Council may have. **The City Council makes the final decision.**

Time Line

| Days | Month 1 | | Month 2 | | Month 3 | | |
|---------------------------------|---------|----|---------|----|---------|----|--|
| | 15 | 30 | 45 | 60 | 75 | 90 | |
| Planning & Zoning | | | | | | | Applicant must attend meeting to present |
| Council 1 st Reading | | | | | | | Applicant must attend meeting to present |
| Council 2 nd Reading | | | | | | | Attend to answer questions |
| Council 3 rd Reading | | | | | | | Attend to answer questions |

- Plan Commission 1st Monday of month 7:00 PM
- City Council 1st and 3rd Tuesday of Month 5:30 PM



CIVIL • STRUCTURAL • MECHANICAL • ELECTRICAL • SURVEY • SPECIALTY

March 31, 2023

Zach Simonsen
Community Development Director
Planning and Zoning Commission, City of Ottumwa
105 E. Third Street
Ottumwa, IA 52501

RE: Rezoning Request For Property at 526 Second Street East

In accordance with the requirements of the City of Ottumwa Planning and Zoning Commission, please be informed that the Ottumwa Community School District is intending construction of a new Athletics Building on property at 526 East Second Street.

The Project will consist of an approximately 29,000 square foot (building footprint) Athletic building. The building will have parking west of the building as well as within the new parking lot currently being built. Additional parking is planned to be added along 2nd Street E.

The rezoning is being requested to better align the zoning with the permitted use.

Thank you.

Sincerely,

Nicholas J. Bettis, P.E.
Civil Engineer



REZONING EXHIBIT OTTUMWA HIGH SCHOOL ATHLETIC COMPLEX OTTUMWA, IOWA

PROJECT LOCATION MAP:



APPLICANT INFORMATION:

APPLICANT/OWNER:
OTTUMWA COMMUNITY SCHOOL DISTRICT
MIKE MCGRODY
1112 N. VAN BUREN
OTTUMWA, IA 52501
641-684-6597

PREPARED BY:
AXIOM CONSULTANTS, LLC
C/O NICK BETTIS
60 E. COURT STREET, UNIT 3
IOWA CITY, IOWA 52240
319-519-6220
NBETTIS@AXIOM-CON.COM

LEGAL DESCRIPTION:

OTTUMWA ORIGINAL LOTS 263-268 BLK 19. AS RECORDED IN BOOK 439 PAGE 305.
DESCRIBED AREA CONTAINS 1.21 ACRES AND IS SUBJECT TO EASEMENTS AND OTHER RESTRICTIONS OF RECORD.

ZONING INFORMATION:

CURRENT ZONING: MULTI-FAMILY RESIDENTIAL MEDIUM DENSITY (R-4)

PROPOSED ZONING: COMMUNITY COMMERCIAL (C-2)

EXISTING ZONING LEGEND:

MULTI-FAMILY RESIDENTIAL MEDIUM DENSITY (R-4)

COMMUNITY COMMERCIAL (C-2)

COMMERCIAL MIXED-USE (C-3)

DOWNTOWN MIXED-USE (C-4)

LIMITED INDUSTRIAL (I-1)



| DATE | DESCRIPTION |
|------|-------------|
| | |
| | |
| | |

OTTUMWA HIGH SCHOOL
ATHLETIC COMPLEX
OTTUMWA, IOWA, WAPELLO COUNTY
OTTUMWA SCHOOL DISTRICT

REZONING EXHIBIT
22-0153 - BETTIS
1 OF 1



LEGAT ARCHITECTS

COMMUNITY SCHOOL DISTRICT

OTTUMWA HIGH SCHOOL ATHLETIC COMPLEX

326 2ND STREET E, OTTUMWA, IOWA 52501

PROJECT

Legal Architects

1111 N. W. 10th St.

Wichita, KS 67202

PHASE

Site Plan/Utility

DATE

10/15/2013

SCALE

AS SHOWN

DESIGNED BY

Legal Architects

CHECKED BY

Legal Architects

DATE

10/15/2013

SCALE

AS SHOWN

PROJECT

Legal Architects

1111 N. W. 10th St.

Wichita, KS 67202

PHASE

Site Plan/Utility

DATE

10/15/2013

SCALE

AS SHOWN

DESIGNED BY

Legal Architects

CHECKED BY

Legal Architects

DATE

10/15/2013

SCALE

AS SHOWN

PROJECT

Legal Architects

1111 N. W. 10th St.

Wichita, KS 67202

PHASE

Site Plan/Utility

DATE

10/15/2013

SCALE

AS SHOWN

DESIGNED BY

Legal Architects

CHECKED BY

Legal Architects

DATE

10/15/2013

SCALE

AS SHOWN

PROJECT

Legal Architects

1111 N. W. 10th St.

Wichita, KS 67202

PHASE

Site Plan/Utility

DATE

10/15/2013

SCALE

AS SHOWN

DESIGNED BY

Legal Architects

CHECKED BY

Legal Architects

DATE

10/15/2013

SCALE

AS SHOWN

OVERALL SITE AND UTILITY PLAN

C2.00
30% CD PLAN

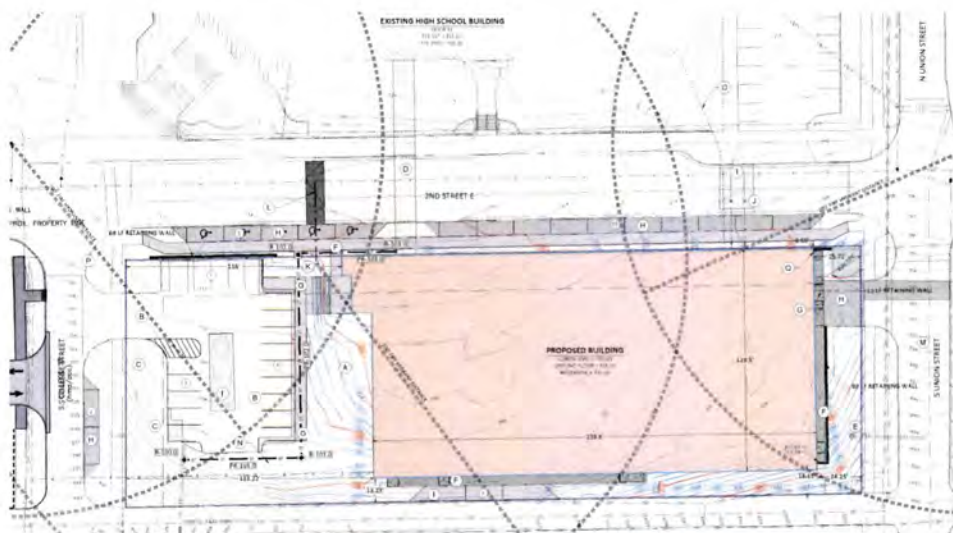

AREA CALCULATIONS

| | |
|-----------------------------------|---------------------|
| TOTAL LOT SIZE | 52,790 SF (1.21 AC) |
| EXISTING BUILDING AREA | 59,472 SF (1.36 AC) |
| EXISTING PAVEMENT AREA | 17,733 SF (0.40 AC) |
| EXISTING OPEN SPACE | 15,605 SF (0.35 AC) |
| POST DEVELOPMENT SUPERFICIAL AREA | 71,145 SF (1.62 AC) |

PROPOSED

| | |
|-----------------------------------|---------------------|
| BUILDING AREA | 17,350 SF (0.39 AC) |
| PAVEMENT AREA | 15,750 SF (0.36 AC) |
| OPEN SPACE | 13,150 SF (0.30 AC) |
| POST DEVELOPMENT SUPERFICIAL AREA | 71,145 SF (1.62 AC) |

PARKING

| | |
|------------------------|--------------------------|
| ON STREET | 20 STALLS @ ALLEY STALLS |
| OFF STREET | 110 STALLS @ HANDICAP |
| OFF SITE PARKING LOT | 115 STALLS |
| TOTAL PARKING PROVIDED | 145 STALLS |

STORM SEWER PIPE TABLE

| PIPE ID | STRUCTURE | STRUCTURE DIA | INVERT | INVERT | LENGTH (FEET) | SLOPE | PIPE DIA | MATERIAL |
|---------|-----------|---------------|--------|--------|---------------|-------|----------|-----------|
| SS-1 | 100 | 36 | 100.00 | 100.00 | 100.00 | 1.00% | 18 | UPPE PIPE |
| SS-2 | 100 | 36 | 100.00 | 100.00 | 100.00 | 1.00% | 18 | UPPE PIPE |
| SS-3 | 100 | 36 | 100.00 | 100.00 | 100.00 | 1.00% | 18 | UPPE PIPE |

STORM SEWER STRUCTURES

| STRUCTURE ID | TYPE | INVERT | INVERT | OUTFLOW PIPE ID |
|--------------|------|--------|--------|-----------------|
| SS-1 | 100 | 100.00 | 100.00 | SS-2 |
| SS-2 | 100 | 100.00 | 100.00 | SS-3 |
| SS-3 | 100 | 100.00 | 100.00 | SS-4 |

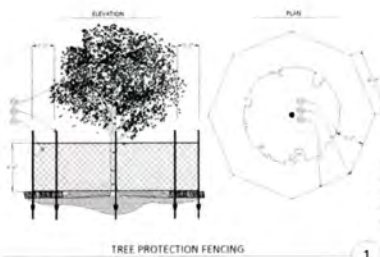

- TREE PROTECTION FENCING NOTES**
- 01 TYPICAL ALL TREES NOTED FOR PROTECTION ON SITE PLANS
 - 02 48" HIGH VISIBILITY ORANGE CONSTRUCTION FENCE
 - 03 STAKE SPACING 6' MAX @ 30'
 - 04 USE ALL TREES & SETBACK DRAW LINE OF PROTECTED TREE

1

KEYNOTES

- A NOT USED
- B EXISTING PARKING LOT PAVING TO REMAIN
- C PROTECT TREE - SEE DETAIL #1
- D PROPOSED 6" BRIDGE TO CONNECT TO EXISTING BUILDING BRIDGE # 133.34. BOTTOM OF BRIDGE = 733.34. CONTRACTOR TO MAINTAIN MINIMUM BRIDGE CLEARANCE OF 14' 0" PER TABLE NO. 1.02 FOR COLLECTION STREETS
- E PROPOSED 6" SIDWALK TO BE INSTALLED ON EXISTING STORM LINE
- F PROPOSED PCC SIDEWALK. SEE DETAIL #3 SHEET C4.00
- G PROPOSED PCC SIDEWALK WITH INTEGRAL CURB. SEE DETAIL #4 SHEET C4.00
- H PROPOSED LOW DENSITY PCC PAVING. SEE DETAIL #5 SHEET C4.00
- I PROPOSED HIGH DENSITY PCC PAVING. SEE DETAIL #6 SHEET C4.00
- J PROPOSED 12" 4" WATER SERVICE AND CURB STOP. AT FIRE PROTECTION LINE. USE TAPPING SEWER AND CURB STOP TO CONNECT TO EXISTING MAIN ALONG 2ND ST. REMOVE AND REPLACE PAVEMENT AS NEEDED.
- K PROPOSED 4" 4" WATER LINE AND FIRE HYDRANT ASSEMBLY WITH GATE VALVE. SEE DETAIL #2. CONNECT TO WATER MAIN PER CITY OF OTTUMWA WATER DEPARTMENT SPECIFICATIONS.
- L REPLACED HMA PAVEMENT AND PCC CURB AND GUTTER FOR INSTALLATION OF FIRE HYDRANT AND ASSOCIATED LINE TO MAIN.
- M PROPOSED 4" SANITARY SERVICE AFTER CLEANOUT. REMOVE AND REPLACE PAVEMENT TO CONNECT TO MAIN WITH SITE.
- N PROPOSED 4" GAS SERVICE. COORDINATE WITH UTILITY COMPANY.
- O PROPOSED FIBER SERVICE. COORDINATE WITH UTILITY COMPANY.
- P PROPOSED SIGN LOCATION
- Q PCC LOCATION

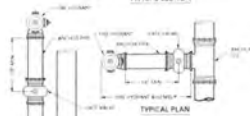
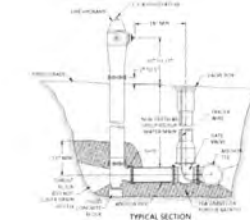

2

Land Use Plan

LAND USE & ZONING COMPATIBILITY MATRIX

The land use to zoning compatibility matrix shows the relationship between the new future land use categories and the existing zoning districts within the City. Land uses and zoning districts have been listed as either compatible ("C") or partially compatible ("PC").

This matrix should be used as the basis for determining the appropriate zoning district(s) for land that is annexed into the City or as a property rezoning is being considered. If the zoning desired for a given property is incompatible with its land use designation, the designation on future land use map should be first amended accordingly. In certain situations an update or amendment to this matrix may be warranted to address changes in development patterns or revisions to the City's zoning code regulations.

Table 10.3 - Land Use & Zoning Compatibility Matrix

| Land Use Categories | Zoning Districts | | | | | | | | | | | | | | | | |
|-------------------------------------|------------------------------------|----------------------|------------------------------|----------------------------|--|--|--|-------------------------------|-----------------------------|--------------------------|---------------------------------|--------------------------|------------------------|------------------|------------------------|------------------------|------------------------------|
| | AG/UR Agricultural / Urban Reserve | RR Rural Residential | R1 Single-Family Low-Density | R-2 Two-Family Low-Density | R-3 Townhouse Residential Moderate-Density | R-4 Multifamily Residential Medium-Density | R-5 Multifamily Residential High-Density | R-MHP Mobile Home Residential | C-1 Neighborhood Commercial | C-2 Community Commercial | CS-1 Commercial Shopping Center | C-3 Commercial Mixed-Use | C-4 Downtown Mixed Use | BP Business Park | I-1 Limited Industrial | L-2 General Industrial | PUD Planned Unit Development |
| Agriculture / Open Space | C | C | | | | | | | | | | | | | | | PC |
| Rural Residential | C | C | PC | | | | | | | | | | | | | | PC |
| Low Density Residential | | PC | C | PC | | | | | | | | | | | | | PC |
| Medium Density Residential | | | PC | C | C | PC | | | | | | | | | | | PC |
| High Density Residential | | | | PC | C | C | C | C | | | | | | | | | PC |
| Downtown Core | | | | | | | | | PC | | | PC | C | | | | PC |
| Office | | | | | | | | | C | PC | PC | PC | PC | PC | | | PC |
| Public, Semi-Public & Institutional | C | C | C | | | | | | | | | | | | | | PC |
| Parks & Recreation | C | C | | | | | | | | | | | | | | | PC |
| Neighborhood Mixed Use | | | | | | | | PC | C | | | PC | C | | | | PC |
| Mixed Use | | | | | | | PC | | C | | | C | C | PC | | | PC |
| Community Commercial | | | | | | | | | C | C | C | C | PC | PC | | | PC |
| Highway Commercial | | | | | | | | | C | C | C | C | PC | PC | | | PC |
| Industrial Business Park | | | | | | | | | | | | | | C | C | PC | PC |
| Industrial | | | | | | | | | | | | | | | PC | C | PC |

Source: Confluence

Land Use Plan

LAND USE & ZONING COMPATIBILITY MATRIX

The land use to zoning compatibility matrix shows the relationship between the new future land use categories and the existing zoning districts within the City. Land uses and zoning districts have been listed as either compatible ("C") or partially compatible ("PC").

This matrix should be used as the basis for determining the appropriate zoning district(s) for land that is annexed into the City or as a property rezoning is being considered. If the zoning desired for a given property is incompatible with its land use designation, the designation on future land use map should be first amended accordingly. In certain situations an update or amendment to this matrix may be warranted to address changes in development patterns or revisions to the City's zoning code regulations.

Table 10.3 - Land Use & Zoning Compatibility Matrix

| Land Use Categories | Zoning Districts | | | | | | | | | | | | | | | | |
|-------------------------------------|------------------------------------|----------------------|------------------------------|----------------------------|--|--|--|-------------------------------|-----------------------------|--------------------------|---------------------------------|--------------------------|------------------------|------------------|------------------------|------------------------|------------------------------|
| | AG/UR Agricultural / Urban Reserve | RR Rural Residential | R1 Single-Family Low-Density | R-2 Two-Family Low-Density | R-3 Townhouse Residential Moderate-Density | R-4 Multifamily Residential Medium-Density | R-5 Multifamily Residential High-Density | R-MHP Mobile Home Residential | C-1 Neighborhood Commercial | C-2 Community Commercial | CS-1 Commercial Shopping Center | C-3 Commercial Mixed-Use | C-4 Downtown Mixed Use | BP Business Park | I-1 Limited Industrial | L-2 General Industrial | PUD Planned Unit Development |
| Agriculture / Open Space | C | C | | | | | | | | | | | | | | | PC |
| Rural Residential | C | C | PC | | | | | | | | | | | | | | PC |
| Low Density Residential | | PC | C | PC | | | | | | | | | | | | | PC |
| Medium Density Residential | | | PC | C | C | PC | | | | | | | | | | | PC |
| High Density Residential | | | | PC | C | C | C | C | | | | | | | | | PC |
| Downtown Core | | | | | | | | | PC | | | PC | C | | | | PC |
| Office | | | | | | | | | C | PC | PC | PC | PC | PC | | | PC |
| Public, Semi-Public & Institutional | C | C | C | PC | PC | PC | PC | | PC | PC | PC | PC | PC | PC | PC | PC | PC |
| Parks & Recreation | C | C | | | | | | | | | | | | | | | PC |
| Neighborhood Mixed Use | | | | | | | PC | | C | PC | | PC | C | | | | PC |
| Mixed Use | | | | | | | PC | | C | | | C | C | PC | | | PC |
| Community Commercial | | | | | | | | | C | C | C | C | PC | PC | | | PC |
| Highway Commercial | | | | | | | | | C | C | C | C | PC | PC | | | PC |
| Industrial Business Park | | | | | | | | | | | | | | C | C | PC | PC |
| Industrial | | | | | | | | | | | | | | | PC | C | PC |

Source: Confluence

received
6-14-23 4:30p

[Faint red stamp]

CITY OF OTTUMWA Staff Summary

**** ACTION ITEM ****

Council Meeting of: Jun 20, 2023

Planning & Development
Department

Zach Simonson

Prepared By

Zach Simonson

Department Head

[Handwritten Signature]

City Administrator Approval

AGENDA TITLE: ORDINANCE NO. 3214-2023: AN ORDINANCE AMENDING THE CODE OF ORDINANCES (MUNICIPAL CODE OF THE CITY OF OTTUMWA, IOWA) BY CHANGING THE ZONING CLASSIFICATION OF PROPERTY KNOWN AS 1508 ALBIA ROAD FROM C-1 TO C-2 IN THE CITY OF OTTUMWA, WAPELLO COUNTY, IOWA

Public hearing required if this box is checked.

RECOMMENDATION: Plan and Zoning Commission recommends to pass third consideration and pass and adopt Ordinance No. 3214-2023.

DISCUSSION: The applicant seeks rezoning the property at 1508 Albia from C-1 to C-2 in order to operate an impound lot. The zoning change would permit Short Term Vehicle Storage to be a permitted use. Short Term Vehicle Storage allows for parking operating and non-operating vehicles on hard surface parking for up to 30 days. Storage of body damaged vehicles would require screening from public rights-of-way, storage longer than 30 days would be prohibited.

Source of Funds:

Budgeted Item: Budget Amendment Needed:

Section 38-966 requires reviewing the following elements in order to consider a rezoning:

1. Conformance to Future Land Use Plan: The Future Land Use Plan identifies the parcel as suitable for Neighborhood Mixed-Use Land Use. This Land Use and Zoning Compatibility Matrix does not identify the C-2 zone as compatible with Neighborhood Mixed-Use land use. Staff believes that regardless of the outcome of the rezoning, the Matrix should be amended to identify the C-2 zone as Partially Compatible. The entire Church Street district is a C-2 zone and is identified for Neighborhood Mixed-Use land use in the Future Land Use Plan. This correction will avoid issues with conditional use permits, changes of use and changes of zone in areas like Church St, Richmond and Albia Rd. This change is included in Comprehensive Plan Amendment 3 which is set for public hearing and adoption May 16.
2. Conformance to goals and objectives of the Comprehensive Plan: The rezoning does not directly advance goals in the comprehensive plan or directly conflict with the comprehensive plan.
3. Compatibility with surrounding development: The surrounding development is largely commercial with a mix of some residential use. Nearby development is C-2 zoned at Fareway. The former use of this parcel included RV sales, which was an existing nonconforming use in the C-1 zone.
4. Potential hardships or nuisances for surrounding development: Operation that strictly conforms to the code would not be expected to produce nuisance or hardship. However, vehicle storage operations tend to exceed limits and create obligations for enforcement.
5. Public utilities: Development will be served by existing utilities.
6. Trend of development: There is not particularly strong trend of development in the area. The Fareway store was completed in 2007 and began some higher intensity use while the Southern Iowa Mental Health use is lower intensity than the previous bowling alley.

ORDINANCE NO. 3214-2023

AN ORDINANCE AMENDING THE CODE OF ORDINANCES (MUNICIPAL CODE OF THE CITY OF OTTUMWA, IOWA) BY CHANGING THE ZONING CLASSIFICATION OF PROPERTY KNOWN AS 1508 ALBIA ROAD FROM C-1 TO C-2 IN THE CITY OF OTTUMWA, WAPELLO COUNTY, IOWA

NOW, THEREFORE, BE IT ORDAINED BY THE CITY COUNCIL OF THE CITY OF OTTUMWA, IOWA, THAT:

SECTION 1

Zoning Ordinance #3105-2015 of the City of Ottumwa, Iowa, as amended and as set forth in Chapter 38 of the Municipal Code, City of Ottumwa, Iowa be and the same is hereby amended and changed to conform with this ordinance and the following described property, to wit:

Part of Auditor's Lot 19 of the Northwest Quarter of the Southwest Quarter of Section 26, Township 72, Range 14 as follows: Beginning at a point 180 feet South and 181 feet West of the Northeast corner of the Northwest Quarter of the Southwest Quarter; thence South 60 feet; thence West 150 feet; thence North 60 feet; thence East 150 feet to the place of beginning.

ALSO

Part of the Northwest Quarter of the Southwest Quarter of Section 26, Township 72 North, Range 14 West of the 5th P.M. in the City of Ottumwa, Wapello County, Iowa, described as follows: Beginning 30 feet South and 181 feet West of the Northeast corner of said NW¼ of the SW¼; thence South 150 feet; thence West 100 feet; thence North 150 feet; thence East 100 feet to the place of beginning. Said tract being a part of Lot 19 of Auditor's Subdivision of the Southwest Quarter of said Section 26, and also a part of Lots 23 and 24 of an unrecorded plat of Silverwood Farm, an Addition to the City of Ottumwa, Wapello County, Iowa.

ALSO

A part of the Northwest Quarter of the Southwest Quarter of Section 26, Township 72 North, Range 14 West of the 5th P.M. in the City of Ottumwa, Wapello County, Iowa, described as follows: Beginning 30 feet South and 281 feet West of the Northeast corner of said NW¼ of SW¼ of Section 26, Township 72, Range 14; thence South 150 feet; thence West 50 feet; thence North 150 feet; thence East 50 feet to the place of beginning.

Be and the same is hereby changed from its present zoning classification of "C-1" Neighborhood Commercial District to "C-2" Community Commercial District.

SECTION 2

The official zoning map of the City of Ottumwa, Iowa duly designated as such, and on file in the office of the City Clerk and the Wapello County Recorder, is hereby amended and changed to conform to this ordinance and the City Clerk, pursuant to Section 38-30 of the Zoning Ordinance #3088-2015, as amended, is hereby directed to record a certified copy of this said ordinance with the Wapello County Recorder and attach a certified copy of this said ordinance to the official zoning map.

SECTION 3

This ordinance shall be in full force and effect, from and after its passage, adoption and approval and publication as required by law, unless a subsequent effective date is set out hereinabove.

SECTION 4

When this ordinance is in effect, it shall automatically supplement, amend and become a part of the said Code of Ordinance (Municipal Code) of the City of Ottumwa, Iowa.

Passed on its first consideration on the 2nd day of May, 2023.

Passed on its second consideration on the 16th day of May, 2023.

Requirement of consideration and vote at two prior council meetings suspended on the ___ day of _____, 2023.

Final passage and adoption on the 20th day of June, 2023.

CITY OF OTTUMWA, IOWA

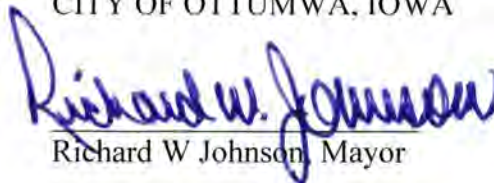
Richard W Johnson, Mayor

___ No action taken by Mayor.

___ Vetoed this ___ day of _____, 2023.

Richard W Johnson, Mayor

___ Repassed and adopted over the veto this ___ day of _____, 2023.

___ Veto affirmed this ___ day of _____, 2023 by failure of vote taken to repass.

___ Veto affirmed, no timely vote taken to repass over veto.

ATTEST:

Chris Reinhard
Chris Reinhard, City Clerk



#5004



Planning and Development
City Hall; Room 204
105 East Third Street
Ottumwa, IA 52501

| APPLICATION TO REZONE PROPERTY | | |
|---|-----------|-----------------|
| APPLICANT INFORMATION | | |
| Name: Joshua Kirby | | |
| Phone: 641-226-4206 | | |
| Address: 910 W Walnut | | |
| City: Bloomfield | State: IA | ZIP Code: 52537 |
| E-mail: Kirbywrecker service@gmail.com | | |
| PROPERTY INFORMATION | | |
| Business Name: Kirby Wrecker Service LLC | | |
| Proposed Property Use: Towing and roadside assistance and vehicle storage | | |
| Property Manager (If different from applicant): | | |
| Address: 1508 Albia Road | | |
| City: Ottumwa | State: IA | ZIP Code: 52501 |
| E-mail: | | |
| REZONE INFORMATION | | |
| Current Zoning Classification C1 | | |
| Requested Zoning Classification C2 | | |
| SIGNATURES | | |
| I authorize the verification of the information provided on this form and have attached all required documentation. | | |
| Signature of applicant: Joshua Kirby | | Date: 4/10/23 |

Submittal Checklist

- Full Legal Description(Deed)
- List of all property owners within 200 feet radius of property
- Letter to the Plan Commission "Why you want the property rezoned"
- Application fee(Non-refundable) \$300.00
- Site Plan

Planning and Zoning Commission and Council

Kirby Wrecker Service LLC. Is requesting rezoning to C2 for the commercial property located at 1508 Albia Rd Ottumwa, IA currently zoned as C1. The reason for this request is to allow the company to fully fulfill its job requirements. Part of those requirements is to have the ability to store vehicles in an impound lot securely. Which the C1 zone prohibits that.

Kirby Wrecker Service is an established Towing and Roadside business in Bloomfield Iowa since 2020. We strive to serve the public and law enforcement with 24/7 dependable services. The need for our services in the Ottumwa community have become very demanding over the past few years. So, after a long search we acquired the property off Albia Rd to expand our business to be of better service. We have included a site map with our goals to improve the property which includes new privacy fencing, accommodation to serve the public and updates to the existing structures. All improvements will be made in compliance with the ordinances of the city and Iowa code.

We have reached out to the surrounding property owners for concerns about our adjustments to the property, as well as provide information about the type of business we will be conducting. In this we all agreed that the suggested adjustments to the property would help deter criminal activity and visually improve the area that we all share.

As for all stored vehicles on this property if granted, said vehicles will always be concealed from public view and will not be on the property for more than 30 days at a time. Once the stored vehicles have exceeded the 20-day storage limit they will be removed from the property. The property will not be used for any repairs or parting of vehicles of any kind. It will be used solely to conduct the towing needs of Ottumwa and store impounded vehicles. Thank you for your consideration.

Sincerely, *Joshua Kirby*
Owner

SITE PLAN

1508 Albia Rd

ottumwa, IA 52501

Parcel ID: 007417540273000

Lot area: 0.17 Acres

Parcel ID: 007417540269000

Lot area: 0.34 Acres

Parcel ID: 007417540181000

Lot area: 0.21 Acres

Paper Size: 11"x17"

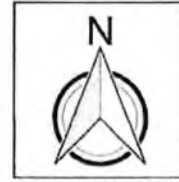

scale 1"=20'

Albia Rd

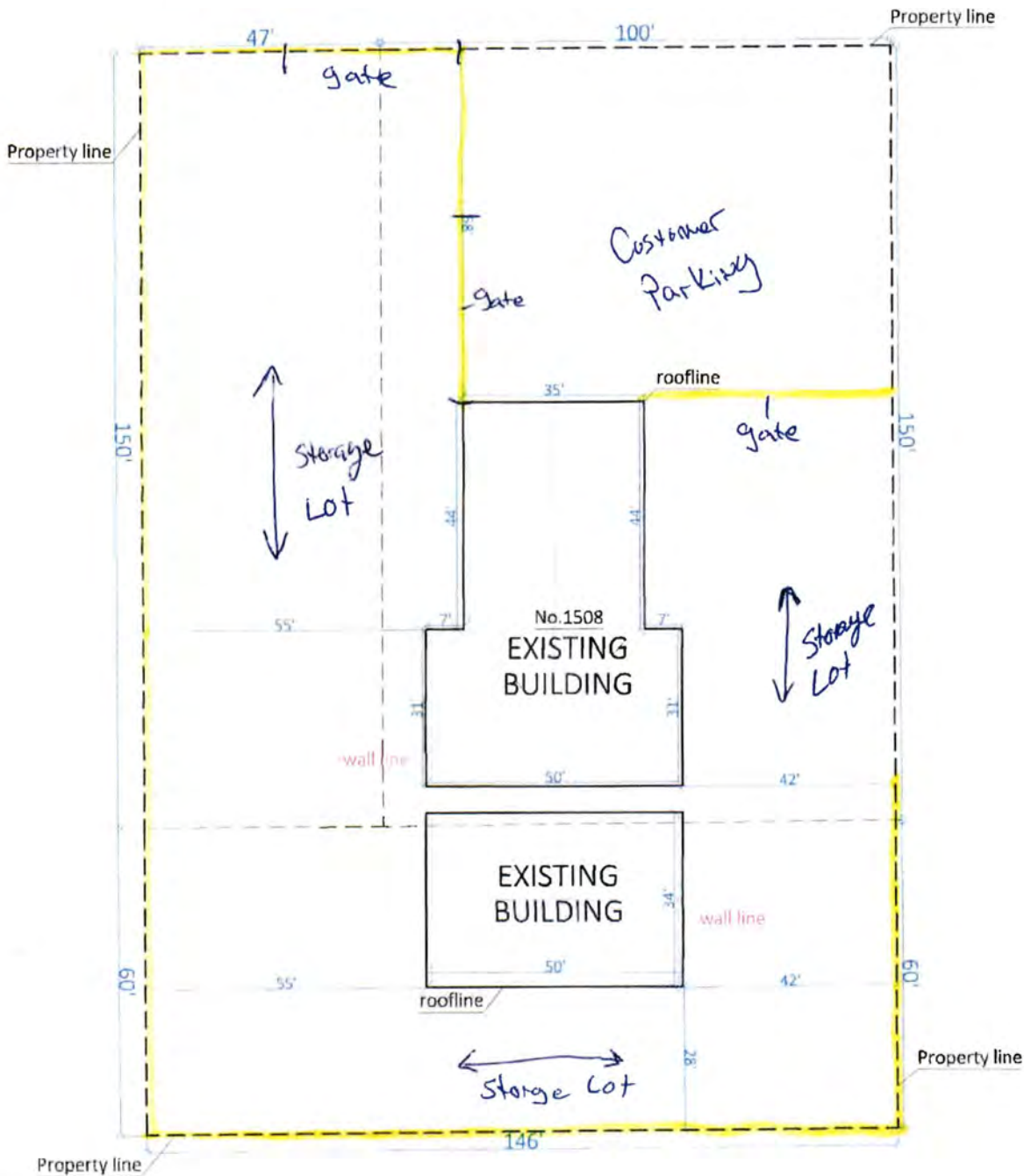

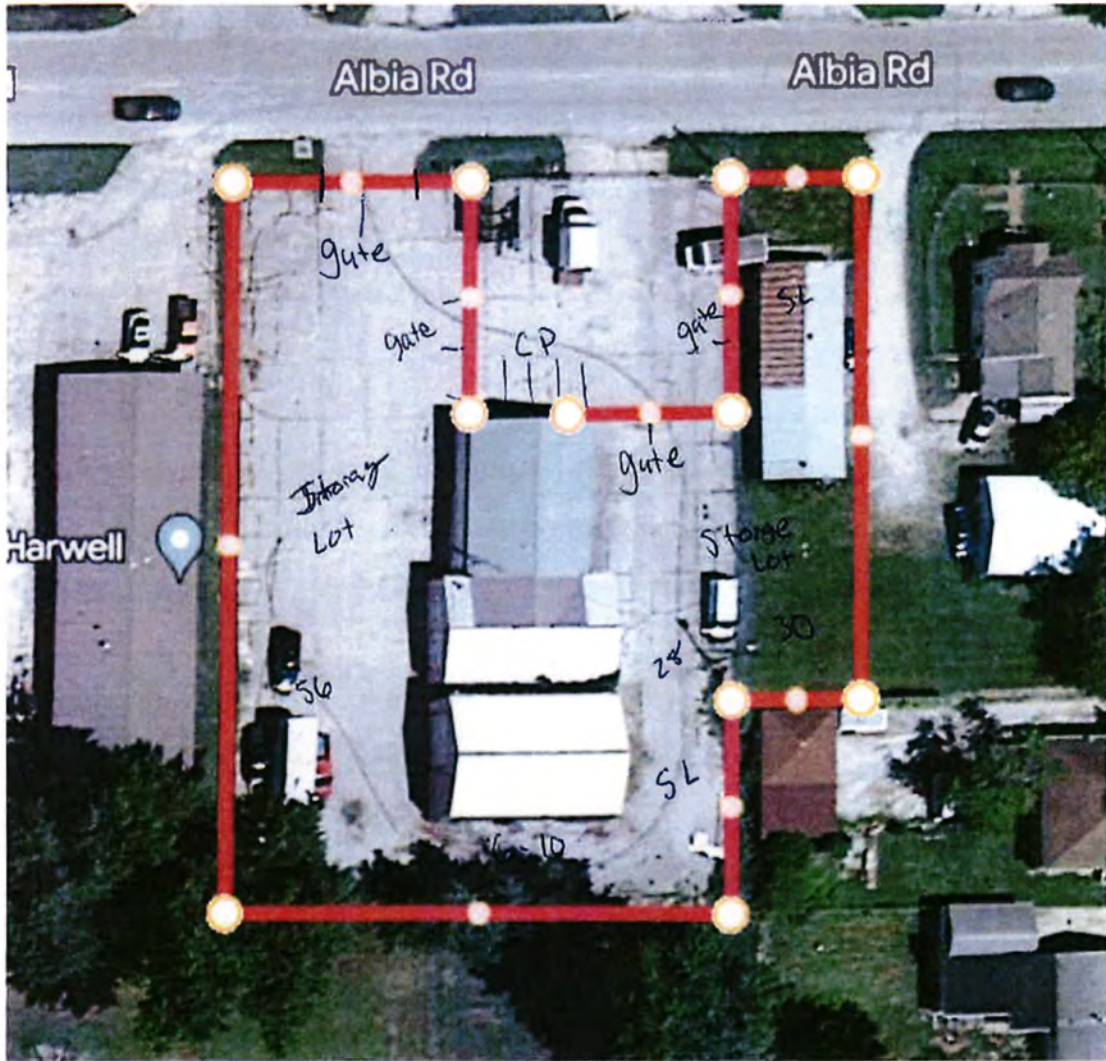

100-120 cars
Pred - Fence

received
6-16-23 10A

6-16-23 10A

CITY OF OTTUMWA
Staff Summary

**** ACTION ITEM ****

Council Meeting of: Jun 20, 2023

Planning & Development
Department

Zach Simonson
Prepared By
Zach Simonson
Department Head



City Administrator Approval

AGENDA TITLE: AUTHORIZE COMMUNITY DEVELOPMENT DIRECTOR TO SIGN ORDER FORM FOR PLACER.AI LOCATION SERVICES DATA PROGRAM AND AGREE TO LICENSE AGREEMENT

Public hearing required if this box is checked.

RECOMMENDATION: AUTHORIZE COMMUNITY DEVELOPMENT DIRECTOR TO SIGN ORDER FORM FOR PLACER.AI LOCATION SERVICES DATA PROGRAM AND AGREE TO LICENSE AGREEMENT

DISCUSSION: Placer.ai is a set of GIS and data tools developed by Placer Labs using cell phone location services data. Placer is able to access location data from cell phone users who have location services enabled and uses a test, proprietary method to aggregate that data to show trends and estimates. The Planning Department has reviewed the program in demonstrations and discussed the platform with peer communities. Staff sees significant

value in a one-year subscription to the platform. The total cost of the subscription is \$20,000, however the John Deere Foundation and Greater Ottumwa Partners in Progress have contributed \$10,000 toward the program reducing the cost to only \$10,000.

This program can generate data for the following use cases:

- Retail trade area. Data can regular traffic to retail districts, particular stores, trends over time, demographics of customers, dwell time, where customers live, where customers went before and after visits, etc.
- Special event data. Within 3 days of special events such as Balloon Races, BVC concerts, etc. data can show total attendance, where attendees live, dwell time, etc.
- Traffic counts. Data can show vehicle street counts. Unlike official DOT data, Placer.ai estimate data is updated in real time, available block by block and direction. This could assist in planning projects and providing specific counts for commercial and industrial site selectors.

Included with the packet is a simple report on the Church St. The report is an example of how Staff could use the platform day-to-day.



PLACER LABS, INC.

ORDER FORM

City of Ottumwa ("Customer") Placer Labs, Inc. ("Placer")
Address: 105 E. Third Street Address: 440 N Barranca Ave., #1277
Ottumwa, Iowa 52501 Covina, California 91723
Contact Person: Zach Simonson Contact Person: Terry Munoz
Email: simonsonz@ottumwa.us Billing Contact Person: Melissa Anderson
Phone: 641-683-0694 Billing Email*: billing@placer.ai
Billing Contact Email: simonsongz@ottumwa.us Billing Phone*: 415-228-2444
*Not for use for official notices.

1. Services.

The services provided under this Order Form (the "Services") include:

- Access, via Placer Venue Analytics Platform ("Placer's Platform"), to all major venues within the United States
• Access, via Placer's Platform, to reports, including Visits, Trade Areas, Customer Journey, Customer Insights, Dwell Times, and Visitation by Hour/Day
• Actionable insights include:
o Accurate foot traffic counts and dwell time
o True Trade Areas displaying frequent-visitors-density by home and work locations
o Customers' demographics, interests, and time spent at relevant locations
o Where customers are coming from and going to, and the routes they take
o Benchmarking of Foot Traffic, Market Share, Audiences, and other key metrics
o Competitive insights
o Void Analysis Reports
• Access to Xtra reports per ad hoc needs; in Excel, KML, Tableau, and other formats: Quarterly Maximum of 26 credits; Annual Maximum of 104 credits
• Premier Customer Support
o Regular meetings with Placer's Customer Success Team
o Live, Virtual Training support as reasonably needed
• Access to STI Demographics Bundle + Mosaic Data Set. The applicable Advanced Demographics and Psychographics are generated using the Input Datasets from the data vendors as set forth below:

Table with 2 columns: Description, Input Datasets Used. Rows include STI Demographics Bundle (PopStats, Spending Patterns, Workplace, Market Outlook) and Experian Mosaic (Mosaic Segmentation).

2. Permitted Uses

The data, information and materials accessible via the Services are referred to as "Placer Data". Customer may use Placer Data solely for the following purposes ("Permitted Uses"): (a) Customer may use Placer Data for Customer's internal business purposes; and (b) Customer may incorporate Placer Data into Research Data, as described and subject to the restrictions below.

“**Research Data**” means datasets and other materials created by Customer that result in any part from Customer’s use of Placer Data. The Customer may share Research Data with current and potential customers, and in marketing materials; provided that the Customer shall cite Placer as a provider of such information (for such purpose only, Placer grants Customer the rights to use the Placer.ai name and logo, provided that any such use of the Placer.ai name and logo must clearly indicate that Placer is the provider of data only, and is not involved in any analysis, conclusion, recommendation). Customer shall not, directly or indirectly, resell, distribute, sublicense, display or otherwise provide Placer Data to any third parties, except that Customer may display Placer Data as part of Research Data.

3. **Term and Termination.**

Initial Term: The initial term of this Order Form will begin on June 01, 2023, and will continue for 12 consecutive months thereafter (the “**Initial Term**”). Each renewal or additional term, if any, is referred to as “**Additional Term**,” and the Initial Term and any Additional Terms are referred to collectively as the “**Term**.”

Additional Term: Following expiration of the Initial Term, this Order Form shall be automatically renewed for additional periods of the same duration as the Initial Term, unless either party provides written notice of non-renewal at least thirty (30) days prior to the expiration of the then-current term.

Termination: Either party may terminate this Order Form upon thirty (30) days’ notice if the other party materially breaches any of the terms or conditions of this Order Form or the Agreement (as defined below), and the breach remains uncured during such thirty (30) days. In addition, Placer may immediately suspend Customer’s access to the Services, or terminate the Order Form, in the event of non-payment by the Customer or breach by Customer of any restrictions regarding usage of the Services. Should either Placer or Customer terminate this Order Form for any reason except for an event of non-payment or breach by Customer, Placer will remit to Customer the prorated Fee attributable to the balance of the Initial Term.

4. **Fees.**

\$20,000/year invoiced: in full on July 01, 2023.

Invoice sent electronically to Customer’s billing contact email via NetSuite.

Customer shall pay the fees set forth above in this Order Form.

Unpaid amounts are subject to a finance charge of 1.5% per month on any outstanding balance, or the maximum permitted by law, whichever is lower, plus all expenses of collection.

Customer is responsible for all applicable taxes arising directly from the Services other than U.S. taxes based on Placer’s net income.

If Customer believes that Placer has billed Customer incorrectly, Customer must contact Placer no later than sixty (60) days after the closing date on the first billing statement in which the error or problem appeared in order to receive an adjustment or credit. Inquiries should be directed to Placer’s customer support department at support@placer.ai.

In the event of any termination, Customer will pay in full for the Services, except as set forth in Section 3.

Placer may increase the fees any time following the Initial Term (but not more frequently than once in any twelve (12) month period). The amount of such annual increase will equal the greater of CPI or five percent (5%) per annum. Placer shall provide Customer with 60 days prior written notice of its intent to increase the fees.

All billing will be sent via electronic invoice to the Customer contact indicated above. Customer shall pay all fees within thirty (30) days of the invoice date.

5. Support.

Placer will use commercially reasonable efforts to provide customer service and technical support in connection with the Services on weekdays during the hours of 9:00 A.M. through 5:00 P.M. Pacific Time, with the exclusion of federal holidays. For any such support, please contact us at support@placer.ai.

6. Mutual NDA.

Each party (the “**Receiving Party**”) understands that the other party (the “**Disclosing Party**”) has disclosed or may disclose business, technical or financial information relating to the Disclosing Party’s business (hereinafter referred to as “**Proprietary Information**” of the Disclosing Party). Proprietary Information of Placer includes, without limitation, non-public information regarding features, functionalities and performance of, and pricing for, the Services. The Receiving Party agrees: (i) to take reasonable precautions to protect such Proprietary Information, and (ii) not to use (except in performance of the Services or as otherwise permitted by the Agreement) or disclose to any third party any Proprietary Information. The foregoing shall not apply with respect to any information that the Receiving Party can document (a) is or becomes generally available to the public, (b) was in the possession of or known to the Receiving Party, prior to disclosure thereof by the Disclosing Party, without any restrictions or confidentiality obligations, (c) was rightfully disclosed to it, without any restrictions or confidentiality obligations, by a third party, (d) was independently developed without use of any Proprietary Information of the Disclosing Party, or (e) is required to be disclosed by law, provided that the Receiving Party provides the Disclosing Party with prompt written notice of such requirement and reasonably cooperates with the Disclosing Party to limit or challenge such requirement. These provisions regarding Proprietary Information shall apply in perpetuity and shall survive any termination of the Order Form or the Agreement.

7. Miscellaneous.

All notices under the Order Form and the Agreement will be in writing and will be deemed to have been duly given (a) upon delivery by a recognized delivery service (e.g., FedEx) with delivery confirmation, (b) upon receipt, if sent by U.S. certified or registered mail, return receipt requested, or (c) when sent via email, if sent during normal business hours of the recipient, and on the next business day if sent after normal business hours of the recipient. Notices shall be sent to the addresses set forth in the Order Form, which addresses may be subsequently modified by written notice given in accordance with these provisions.

Customer grants Placer the right to use Customer’s company name and company logo, for Placer’s promotional purposes.

This Order Form is entered into by and between Customer and Placer effective as of the date of the last signature below. This Order Form and use of the Services are governed by, and Customer and Placer agree to, the License Agreement located at <https://www.placer.ai/placer-license-agreement/> (the “**Agreement**”); provided, however, that in the event of any conflict between this Order Form and the Agreement, this Order Form shall control. Unless otherwise defined in this Order Form, capitalized terms herein have the same meaning as in the Agreement.

“**Customer**”

City of Ottumwa

“**Placer**”

Placer Labs, Inc.

| |
|--------|
| By: |
| Name: |
| Title: |
| Date: |

| |
|------------------------------------|
| By: |
| Name: Vernell Wisdom |
| Title: Head of Contract Management |
| Date: |



Church Street Retail Ottumwa IA (test)

Ottumwa, IA

Last 12 Months

Export

Church Street Retail Ottumwa IA (test) is a Custom-POI which wasn't 'verified' by Placer

[Learn More](#)

Trade Area

Venues:

Church Street Retail Ottumwa...

| | | | |
|---------------|---------|--------------|----------------|
| By: | Metric: | Min. Visits: | Visualization: |
| Home Location | Visits | 1 | Gradient |

The locations shown are obfuscated for privacy and randomly placed within a census block. They do not represent actual home addresses. [Learn more](#)

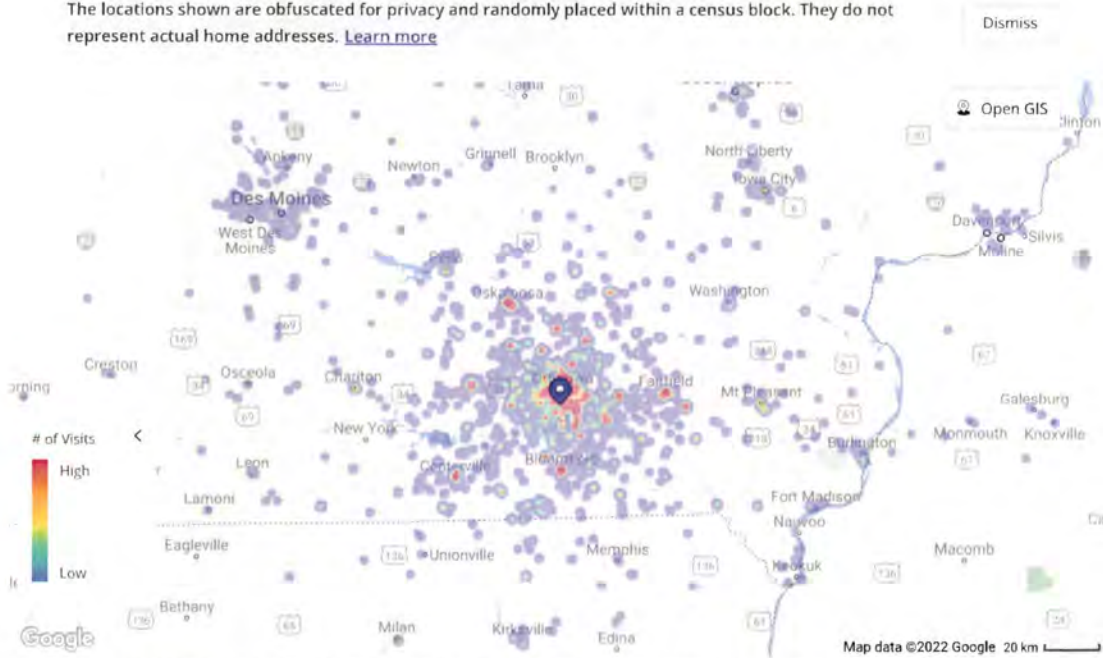

The locations shown are obfuscated for privacy and randomly placed within a census block. They do not represent actual home addresses. [Learn more](#)

Trade Area Coverage by Distance

Church Street Retail ...
Ottumwa, IA

| | | | |
|-------------|---------------|--------------|------------|
| Metric: | By: | Min. Visits: | View: |
| % of Visits | Home Location | 1 | Cumulative |

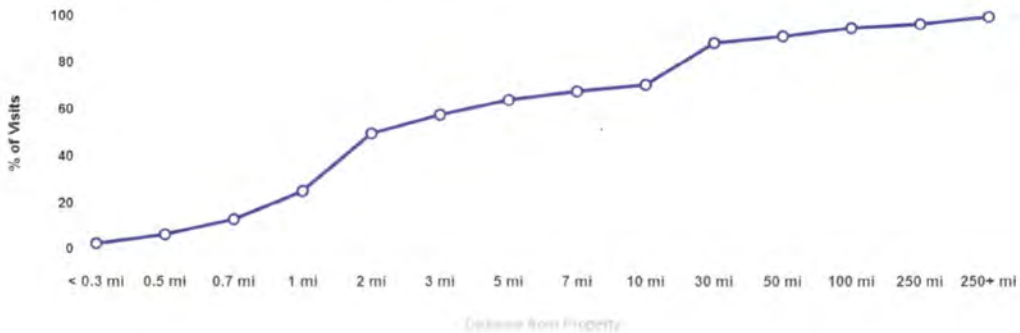

Trade Area Profile

Venues:

| | | | | | |
|------------------|--------------|--------------|--------------|---------|------------------|
| Trade Area Type: | Traffic Vol: | Traffic Vol: | Traffic Vol: | Within: | Allocation Type: |
|------------------|--------------|--------------|--------------|---------|------------------|

Placer - Church Street Retail Ottumwa IA (test) - Trade Area

True Trade Area 40 % 60 % 80 % 50 mi Weighted Centroid

Show Map:

On



35: Demographic Dimensions Census 2017 (ACS) Census 2019 (ACS) More

Benchmark with:
 Nationwide Default

● 40 % Traffic ● 60 % Traffic ● 80 % Traffic

Overview

| | 40 % Traffic | 60 % Traffic | 80 % Traffic |
|-----------------------------------|--------------|--------------|--------------|
| Population | 14,582 | 21,942 | 46,902 |
| Pop density (per sq mile) | 1,552 | 766 | 584 |
| Area (based on blockgroups) sq mi | 9.39 | 28.65 | 80.37 |

Households

Gender

Age

Age - Male

Age - Female

Population by Generation

Ethnicity

Hispanic or Latino

Household Income

| | 40 % Traffic | 60 % Traffic | 80 % Traffic |
|---------------------------|--|---|---|
| Household Average Income | \$49,2... 56 | \$53,4... 60 | \$59,3... 67 |
| Average Income per Person | \$21,0... 62 | \$22,9... 67 | \$25,2... 74 |
| Household Median Income | \$39,4... 62 | \$40,5... 64 | \$43,3... 69 |
| <\$10K | 556 (9.1... 150) | 705 (7.7... 127) | 1,388 (7.3... 121) |
| \$10K - \$15K | 458 (7.5... 174) | 667 (7.2... 168) | 1,517 (8% 186) |
| \$15K - \$20K | 504 (8.2... 187) | 680 (7.4... 188) | 1,239 (6.5... 148) |
| \$20K - \$25K | 284 (4.6... 103) | 472 (5.1... 113) | 1,041 (5.5... 121) |

Placer - Church Street Retail Ottumwa IA (test) - Trade Area

| | | | | | | |
|-----------------|-----|-------------|-----|-------------|-------|-------------|
| \$25K - \$30K | 409 | (6.7... 152 | 630 | (6.8... 156 | 1,220 | (6.4... 146 |
| \$30K - \$35K | 444 | (7.2... 159 | 702 | (7.6... 147 | 1,157 | (6.1... 133 |
| \$35K - \$40K | 464 | (7.6... 180 | 689 | (7.5... 177 | 1,250 | (6.6... 156 |
| \$40K - \$45K | 500 | (8.2... 194 | 595 | (6.5... 154 | 1,040 | (5.5... 130 |
| \$45K - \$50K | 333 | (5.4... 141 | 485 | (5.3... 137 | 892 | (4.7... 122 |
| \$50K - \$60K | 474 | (7.7... 103 | 639 | (6.9... 92 | 1,414 | (7.4... 99 |
| \$60K - \$75K | 547 | (8.9... 92 | 903 | (9.8... 101 | 2,049 | (10... 111 |
| \$75K - \$100K | 595 | (9.7... 76 | 968 | (10... 83 | 2,231 | (11... 92 |
| \$100K - \$125K | 319 | (5.2... 57 | 514 | (5.6... 61 | 1,183 | (6.2... 68 |
| \$125K - \$150K | 171 | (2.8... 46 | 288 | (3.1... 32 | 652 | (3.4... 57 |
| \$150K - \$200K | 32 | (0.5... 8 | 176 | (1.9... 26 | 425 | (2.2... 33 |
| >\$200K | 38 | (0.6... 8 | 98 | (1.1... 14 | 327 | (1.7... 22 |

Family Size

Education

Labor Force

Marital Status

Family Households

Transport to Work

Travel Time to Work

Housing Units

Occupied Housing Units

Vacant Housing Units

Value of Owner-Occupied Housing Units

Types of Housing Units Structure

Health Insurance

SNAP Households

Metrics

Property:

Church Street Retail Ottumwa...



| | | | |
|----------------|-----------|-----------------|-------|
| Visits | 357.8K | Visitors | 71.5K |
| Visits / sq ft | N/A | Visit Frequency | 5.01 |
| Size - sq ft | N/A (GLA) | Panel Visits | 14.9K |

Visits Trend

Church Street Retail ...

Ottumwa, IA



Metric:

Aggregation:

Visits

Weekly

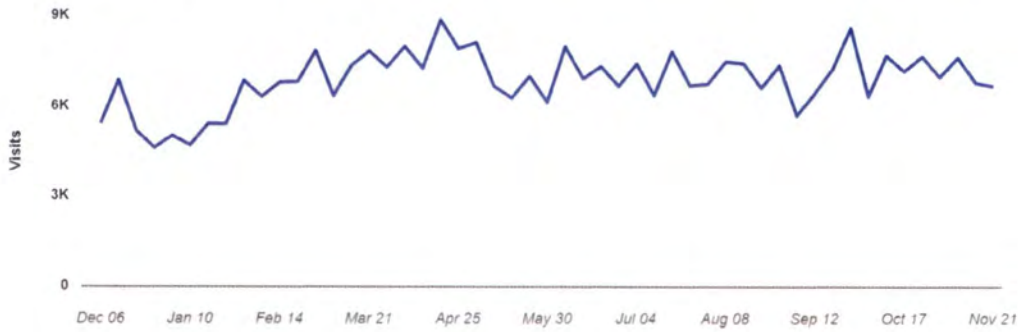

Market Landscape

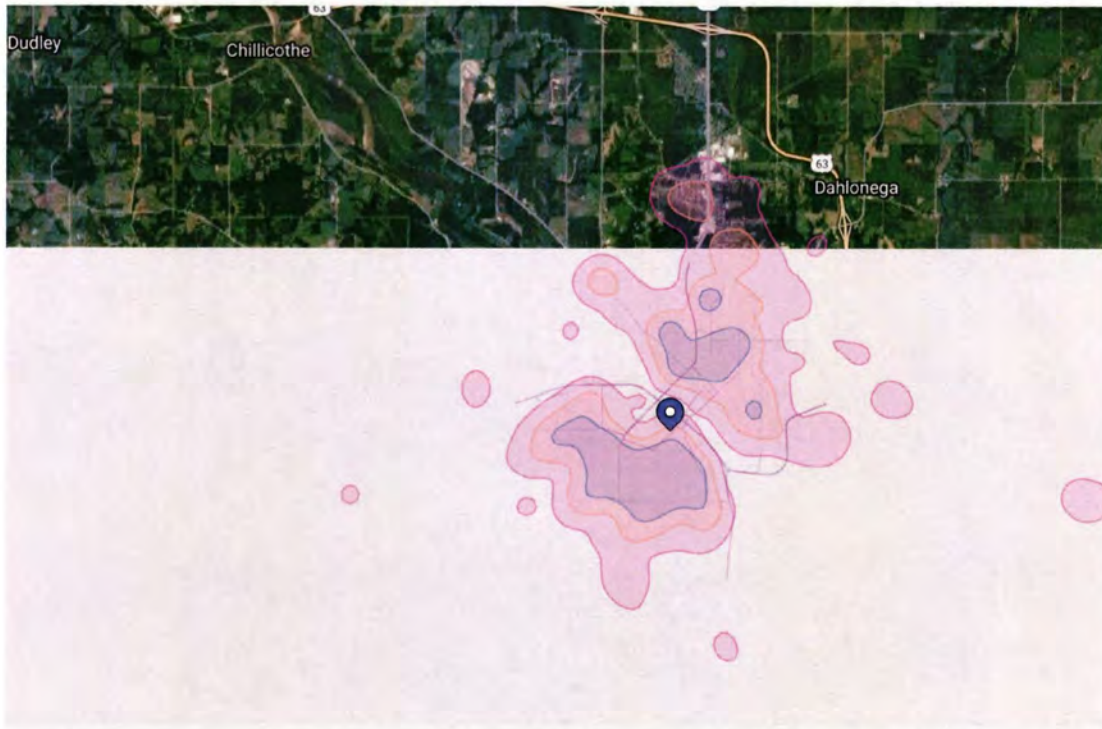

Favorite Places

Category: **All Categories** Min. Visits: **1**

Church Street Retail Ottumwa IA (test) / Ottumwa, IA

| Rank | Name | Distance | Visitors |
|------|---|----------|---------------|
| 1 | Walmart / 1940 Venture Dr, Ottumwa, IA 52501 | 1.9 mi | 55K (77%) |
| 2 | Quincy Place / 1110 N Quincy Ave, Ottumwa, IA 52501 | 1 mi | 52.4K (73.3%) |
| 3 | Menards / 1898 Venture Dr, Ottumwa, IA 52501-3767 | 1.8 mi | 45.8K (64.1%) |
| 4 | Hy-Vee / 1025 N Quincy Ave, Ottumwa, IA 52501 | 1.1 mi | 39.2K (54.8%) |
| 5 | Greater Ottumwa Park / Teal Dr, Ottumwa, IA 52501 | 0.6 mi | 35.2K (49.3%) |

Visitor Journey

Property: Church Street Retail Ottumwa...

Show by: **Location** Category Category Group Show Home/Work: On

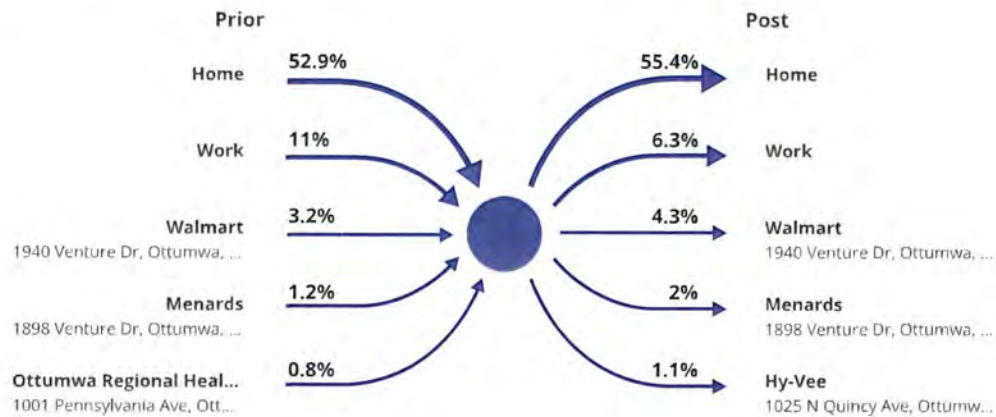

Visitor Journey - Routes

Property: Church Street Retail Ottumwa...

Journey Direction: **To Property** From Property

To protect individual privacy, the beginning points shown for each route are approximations and do not represent actual home locations. [Learn more](#)

Dismiss



Placer - Church Street Retail Ottumwa IA (test) - Overview



To protect individual privacy, the beginning points shown for each route are approximations and do not represent actual home locations. [Learn more](#)

Hourly Visits

Church Street Retail ...
Ottumwa, IA

Metric:
Visits

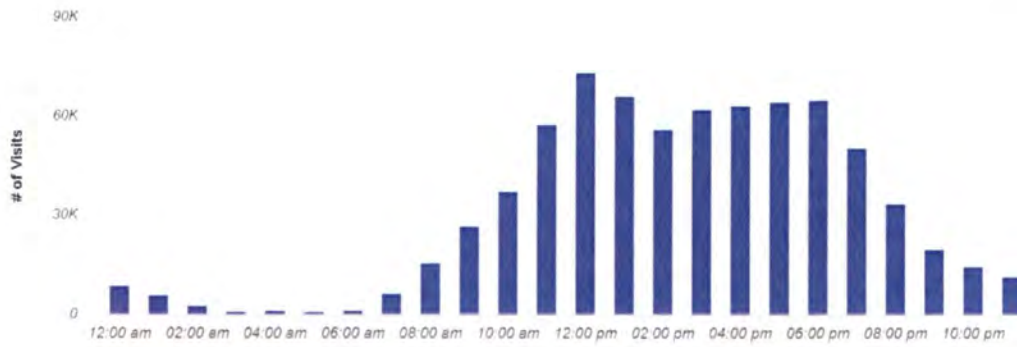

Daily Visits

Church Street Retail ...
Ottumwa, IA

Metric:
Visits

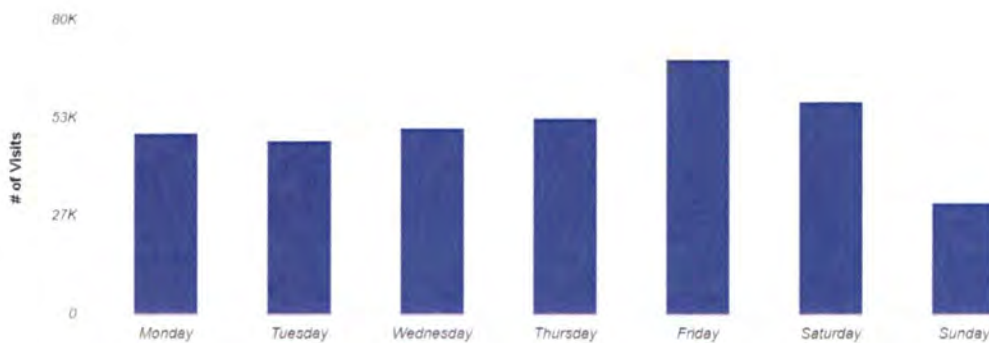

Length of Stay

Church Street Retail ...
- Ottumwa, IA

Metric:

Visits

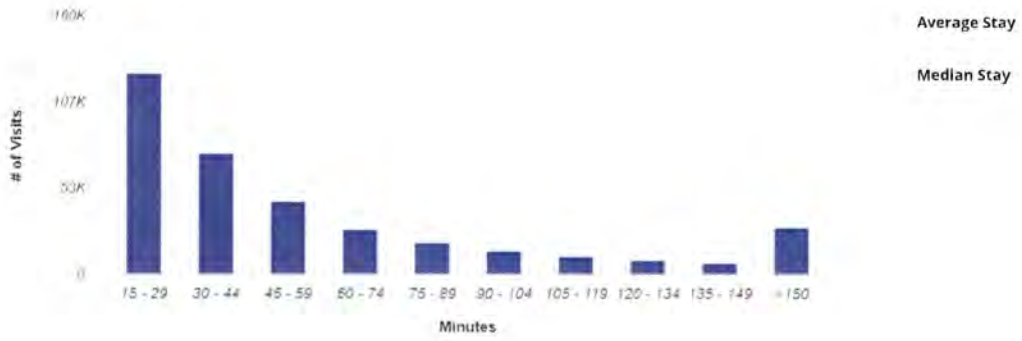

received

6:15:23 1030A

CITY OF OTTUMWA

Staff Summary

**** ACTION ITEM ****

Council Meeting of: June 20, 2023

Larry Seals

Prepared By

Larry Seals
Department Head

Engineering

Department

[Signature]

City Administrator Approval

AGENDA TITLE: Approve purchase of Parking Lot Light poles for the Troeger Parking Lot Project.

**Public hearing required if this box is checked. **

The Proof of Publication for each Public Hearing must be attached to this Staff Summary. If the Proof of Publication is not attached, the item will not be placed on the agenda.

RECOMMENDATION: Approve the purchase of light poles and light fixtures for the Troeger Parking Lot and Bridge View Parking Lot expansions projects.

DISCUSSION: During the design of the Troeger Parking Lot and Bridgeview Parking Lot Expansion projects, we included the concrete light pole bases and conduits in the construction plans. It was decided to order and install the lights for both projects with in-house crews to reduce purchase and installation cost.

We requested quotes from two suppliers with the lowest bid from 3E with a price of \$16,901.28

| | | Bid | Budgeted |
|-----------------------------------|-------------|----------------|----------------|
| 3M | \$16,901.28 | \$ 16,901.28 | |
| Crescent Electric | \$17,885.50 | | |
| Troeger Parking Lot | | \$ 608,859.25 | \$ 569,377.50 |
| Bridgeview Parking Lot Expansion | | \$ 473,143.50 | \$ 574,256.00 |
| Gravel Overflow East of Jefferson | | | \$ 40,000.00 |
| | | \$1,098,904.03 | \$1,183,633.00 |

Source of Funds: CIP

Budgeted Item: Yes

Budget Amendment Needed: No



610 GATEWAY DR
OTTUMWA, IA 52501-2305
P 641-682-8181 F 641-682-0922



QUOTATION

| QUOTE DATE | QUOTE # | PAGE # |
|------------|------------|--------|
| 04/21/2023 | S511333421 | 1 of 1 |

CUST #: 190632

QUOTE TO:

CITY OF OTTUMWA
ACCOUNTS PAYABLE
105 E 3RD ST
OTTUMWA, IA 52501-2999

SHIP TO:

CITY OF OTTUMWA-SHOP ACCT
ACCOUNTS PAYABLE
105 E 3RD ST
OTTUMWA, IA 52501-2999

| REQUESTED BY | | REFERENCE | ACCOUNT MANAGER | |
|---------------|-----------|---|-----------------------|-----------|
| GREG CANTRELL | | BRIDGEVIEW PARKING | AARON G WIRT | |
| QUOTED BY | | TERMS | FREIGHT TERMS | |
| ROGER D MCCOY | | | FREIGHT IF APPLICABLE | |
| ORDER QTY | AVAILABLE | DESCRIPTION | UNIT PRICE | EXT PRICE |
| 9 ea | | QUOTATION-ITEM-PRICE/EACH RSS25D5-4 HAPCO 25'ROUND STRAIGHT POLE COLOR TO BE DETERMINED | 1005.000/ea | 9045.00 |
| 9 ea | | QUOTATION-ITEM-PRICE/EACH B2351 HAPCO ANCHOR BOLTS | 70.500/ea | 634.50 |
| 1 ea | | QUOTATION-ITEM-PRICE/EACH HAPCO CUSTOM COLOR ADDER | 812.000/ea | 812.00 |
| 8 ea | | QUOTATION-ITEM-PRICE/EACH RSX1-LED-P4-50K-R4-HVOLT-RPA-DNAXD LITHONIA LED 480v ROUND | 520.000/ea | 4160.00 |
| 7 ea | | QUOTATION-ITEM-PRICE/EACH RSX1-LED-P4-50K-R4-MVOLT-RPA-DNAXD LITHONIA LED MVOLT ROUND | 462.000/ea | 3234.00 |

PRICES SUBJECT TO CHANGE
QUANTITIES AVAILABLE SUBJECT TO PRIOR SALE
PLEASE SEE WWW.CESCO.COM FOR STANDARD TERMS
AND CONDITIONS

* This line is taxable

| | |
|---------------|----------|
| SUBTOTAL | 17885.50 |
| S&H CHARGES | 0.00 |
| ESTIMATED TAX | 0.00 |
| AMOUNT DUE | 17885.50 |



ELECTRICAL ENGINEERING & EQUIPMENT CO.
 2800 NORTH COURT
 OTTUMWA, IA52501
 (641)226-5103 FAX (641)226-5140
 www.3e-co.com

QUOTE

CUST #: 210048
 SHIP TO: CITY OF OTTUMWA
 CITY HALL
 105 E 3RD ST
 OTTUMWA, IA 52501-2904

BILL TO: CITY OF OTTUMWA
 CITY HALL
 105 E 3RD ST
 OTTUMWA, IA 52501-2904

CORRESPONDENCE TO: Electrical Engineering & Equip
 953 73RD ST
 WINDSOR HEIGHTS, IA 50324-1031

| | | |
|-----------|------------|------------|
| TAKEN BY | QUOTE DATE | QUOTE NO. |
| Cwit | 04/12/23 | 8223325-00 |
| P.O. NO. | | PAGE # |
| | | 1 |
| PLACED BY | | |

| | | |
|--------------|-----------|----------------|
| INSTRUCTIONS | REFERENCE | CASH DISCOUNT: |
| | | |
| SHIP POINT | SHIP VIA | SHIPPED |
| 3E - OTTUMWA | WILL CALL | |
| | | IF PAID BY: |

| LINE NO. | PRODUCT AND DESCRIPTION | QUANTITY ORDERED | QUANTITY B.O. | QTY SHIPPED | QTY. U/M | NET PRICE | AMOUNT (NET) |
|----------|--|------------------|-------------------|-------------|------------------------|-----------|----------------------|
| 1 | HAP RSS25D5-4 5"X5"X.180"X25'XCUSTOM This price includes Anchor bolts. | 9 | | 9 | EACH | 953.34 | 8580.06 |
| 3 | HAPCO CUSTOM COLOR ADDER Non Stock | 1 | | 1 | EACH | 750.00 | 750.00 |
| 4 | LTH RSX1 LED P4 50K R4 HVOLT RPA DNAXD 480 VOLT | 8 | | 8 | EACH | 532.23 | 4257.84 |
| 5 | LTH RSX1 LED P4 50K R4 MVOLT RPA DNAXD 120-277V | 7 | | 7 | EACH | 473.34 | 3313.38 |
| 4 | Lines Total | | Qty Shipped Total | 25 | Total Invoice Total | | 16901.28 16901.28 |

Last Page

THIS IS NOT AN OFFER TO CONTRACT, BUT MERELY A QUOTATION OF CURRENT PRICES FOR YOUR CONVENIENCE AND INFORMATION. ORDERS BASED ON THIS QUOTATION ARE SUBJECT TO YOUR ACCEPTANCE OF THE TERMS AND CONDITIONS LOCATED AT SALES.OUR-TERMS.COM, WHICH WE MAY CHANGE FROM TIME TO TIME WITHOUT PRIOR NOTICE. WE MAKE NO REPRESENTATION WITH RESPECT TO COMPLIANCE WITH JOB SPECIFICATIONS.

received
6/9/23 3:40pm

CITY OF OTTUMWA
Staff Summary

**** ACTION ITEM ****

Council Meeting of : Jun 20, 2023

Administration
Department

Barbara Codjoe
Prepared By
Barbara Codjoe
Department Head



City Administrator Approval

AGENDA TITLE: Resolution No. 92-2023 - Approve Collective Bargaining Agreement with Ottumwa Police Union Teamster's Local #238

Public hearing required if this box is checked.

RECOMMENDATION: Pass and Adopt Resolution #92-2023.

DISCUSSION: Our current Collective Bargaining agreement with the Ottumwa Police Union is expiring June 30, 2023. Attached is the updated agreement by and between the City of Ottumwa, Iowa and the Teamsters Local 238, representing Police Officers and Communication Specialists, commencing on July 1, 2023 and continuing through June 30, 2028.

This contract has been ratified by the union.

Source of Funds: N/A

Budgeted Item: Budget Amendment Needed:

Items to note that changed in the contract:

- 1) Incorporate three (3) MOU's previously passed and signed into contract.
- 2) Clean up wording and reorganize collective bargaining agreement to flow better moving around articles and sections.
 - a. Remove "his/hers" from the entire collective bargaining agreement and replace with "their".
 - b. Clean up table of contents and article numbers
 - c. Replace Police Supervisor with Police Sergeant
- 3) Hours of Work / Duty
 - a. Add in section regarding K9 officers.
 - b. Shift Differential - Remove "a majority of their hours". Added Communication Specialists to receive shift differential
- 4) Dues Check off and Deductions – remove as per Iowa Code 20.
- 5) Vacation
 - a. Contract shows differently than what we have been practicing. Updated years to show current practice.
 - b. Adjusted accruals based on 2184 annual hours worked
- 6) Casual
 - a. Adjust to receive 48 hours (4 days x 12 hours per day) for those working 2184 hours per year
- 7) Holidays
 - a. Adjust to 132 hours from 88 hours (11 holidays x 12 hours per day) for those working 2184 hours per year
- 8) Insurance
 - a. Remove section 1 including all bullet points underneath
 - b. Remove Section 3 – joint insurance committee – do not have
- 9) Seniority – Lay off – Job Abolishment – remove section 2 as per Iowa Code 20.
- 10) Field Training Officer – add that the hours spent serving in this role will be included in overtime rate
- 11) Wages
 - a. Officers
 - i. Create salary structure of Start, 1 year, 2 year, 3 year, 4 year, 5 year, 6 year, 7 year, 8 years or more
 1. 8 years or more step – increase of 6% over previous year (this is the anchor)
 2. Standardize the difference between each step according to a scale
 - b. Communication Specialist
 - i. Market Adjustment of \$2 per hour starting 7/1/2023
 - ii. Salary increases of 6% each year

Financial Impact

Overtime being at 84 hours instead of 86 would add approximately an extra 250 hours of overtime per year to the department. With a new average hourly wage of \$34 per hour, this will add approximately \$12,750 in overtime to the department each year.

Salaries and overtime changes would add an additional \$249,535 to the budget per year for the officers and dispatch. When completing the budget for FY24, we did budget for the majority of the salaries and an additional \$8,000 in overtime. We budgeted on the cautionary side and rounded items up to ensure we would be able to cover the costs.

Totaling salary and overtime together and comparing to what we budgeted, this will cost us an extra \$12,000 per year.

Accruals - Police officers switched to 12 hour days which increased their hours worked annually. A standard 40 hour per week position works 2080 hours annually. For Police officers (and sergeants), they work 2184 hours annually. While they worked more hours annually, they were accruing at the rate of 2080 hours.

RESOLUTION NO. 92-2023

RESOLUTION AUTHORIZING THE APPROVAL OF A COLLECTIVE BARGAINING AGREEMENT BETWEEN THE CITY OF OTTUMWA, IOWA AND OTTUMWA POLICE UNION TEAMSTER'S LOCAL #238

WHEREAS, the City of Ottumwa, Iowa had approved a Collective Bargaining Agreement between the City of Ottumwa and the Ottumwa Police Union Teamster's Local #238 on November 20, 2018 commencing on January 1, 2019 through June 30, 2023 and;

WHEREAS, a retention and recertification election was conducted in October 2022 and ordered on November 18, 2022 that Teamsters #238 is recertified as the exclusive bargaining representative of the bargaining unit of employees of the City of Ottumwa, and;

WHEREAS, staff has drafted an updated Collective Bargaining agreement along with the Ottumwa Police Union Teamster's Local #238 to meet the needs of both employee and employer and finds that approval of said collective bargaining agreement, as revised, would be in the best interest of the City and the employees of the City, and;

WHEREAS, the Ottumwa Police Union Teamster's Local #238 has ratified the updated Collective Bargaining agreement, and;

WHEREAS, the City Council of the City of Ottumwa, Iowa desires to approve the new Collective Bargaining Agreement

NOW, THEREFORE, BE IT RESOLVED, by the City Council of the City of Ottumwa, Iowa, that the attached Collective Bargaining Agreement by and between the City of Ottumwa, Iowa and the Ottumwa Police Union Teamster's Local #238 is hereby adopted with an effective date of July 1, 2023.

BE IT FURTHER RESOLVED, by the Ottumwa City Council of the City of Ottumwa, Iowa, that the Mayor and City Clerk are hereby authorized and directed to execute said resolution.

PASSED, ADOPTED and APPROVED this 20th day of June 2023.

CITY OF OTTUMWA, IOWA

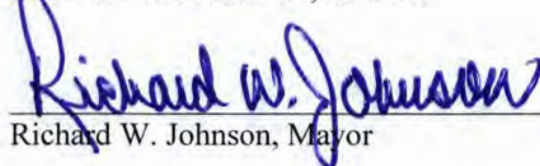
Richard W. Johnson, Mayor

ATTEST:

Christina Reinhard, City Clerk

COLLECTIVE BARGAINING AGREEMENT

BETWEEN

CITY OF OTTUMWA

AND

**OTTUMWA POLICE UNION
TEAMSTER'S LOCAL #238**

**FOR THE PERIOD
OF
JULY 1, 2023 THROUGH JUNE 30, 2028**

TABLE OF CONTENTS

| | | Page |
|-----------------|---------------------------------------|------|
| Article 1 | Purpose of Agreement | 3 |
| Article 2 | Laws Applicable | 3 |
| Article 3 | Recognition | 3 |
| Article 4 | Duration of Agreement | 3 |
| Article 5 | Negotiations | 3 |
| Article 6 | Job Classification & Salary Schedules | 4 |
| Article 7 | Hours of Work/Duty | 5 |
| Article 8 | Overtime | 6 |
| Article 9 | Recognized Holidays | 9 |
| Article 10 | Vacation | 9 |
| Article 11 | Sick Pay | 12 |
| Article 12 | Leave with Pay | 14 |
| Article 13 | Leave without Pay | 15 |
| Article 14 | Insurance | 15 |
| Article 15 | Equipment | 16 |
| Article 16 | Disciplinary Procedures | 17 |
| Article 17 | Grievance Procedures | 17 |
| Article 18 | Seniority – Lay Off – Job Abolishment | 19 |
| Article 19 | Miscellaneous | 19 |
| Article 20 | Management Rights Clause | 20 |
| Article 21 | Employees Rights Clause | 20 |
| Article 22 | Amendment | 20 |
| Article 23 | Savings Clause | 20 |
| SIGNATURES | | 21 |
| SALARY SCHEDULE | | 22 |

This agreement made and entered into this 5th day of April, 2023 by and between the City of Ottumwa, Iowa a municipal corporation, referred to hereinafter as Employer, or City; and the Ottumwa Police Union, Teamster's Local #238, referred to hereinafter as Union or Local #238.

ARTICLE 1
PURPOSE OF AGREEMENT.

The City of Ottumwa and Teamsters Local 238 agree the purpose and intent of this agreement is to negotiate in good faith all subjects covered by the Code of Iowa Chapter 20.9.

ARTICLE 2
LAWS APPLICABLE.

This agreement is made, executed and entered into pursuant to and under authority of the Constitution and the Common and Statutory Laws of the State of Iowa, and any part of this agreement which conflicts shall be null and void and of no force and effect.

ARTICLE 3
RECOGNITION.

The Employer recognizes the Union as the sole and exclusive bargaining agent for the purpose of bargaining for employees in the following positions: Police Officers and Dispatchers and for all of its employees in the bargaining unit established and certified pursuant to the order of the Public Employment Relations Board of the State of Iowa, case number 1774 or amendments thereto. Excluded from the bargaining unit shall be the Chief of Police, Police Lieutenant, Police Sergeant, Chief's Secretary, DataCom Supervisor, part-time dispatchers, and those employees excluded as determined by the Iowa Public Employment Relations Board, after hearing related solely to the City of Ottumwa.

ARTICLE 4
DURATION OF AGREEMENT.

This agreement shall be in effect from and after 12:00 A.M. July 1, 2023, until 11:59 P.M. on June 30, 2028 and from year to year thereafter unless either party hereto gives the other party written notice of its desire to terminate or modify the same on or before September 15th of the preceding year.

Wages and insurance sections of this agreement shall be open for negotiations in years 4 and 5.

ARTICLE 5
NEGOTIATIONS.

Section 1. Employer will meet with the union with respect to establishing wages, hours, and working conditions of employment as necessity requires and shall be concluded prior to time permitted for submission and certification of said budget to the County Auditor of Wapello

County. Conferences and meetings as are required concerning such matters as the interpretation of this Agreement, working conditions and grievances shall be held pursuant to the terms of this Agreement, and if not so provided may be held at the call of either party of this Agreement at an agreed upon time and place.

Section 2. The following general procedures shall govern such negotiations and conferences:

- a. The Employer shall be represented by such members of its bargaining team as it deems necessary. In addition, each party may utilize a secretary and expert professional representatives as said party deems necessary. However, due to the fact that it is desirable by both parties that said meetings be efficient and orderly, private citizens representing either party shall be present only upon agreement of both parties. Nothing contained in this section shall be deemed to infer the desire or agreement by the parties to the violation of Chapter 28A of the Code of Iowa, as amended known as the Open Meeting Law and said Law shall be adhered to if and where mandated.
- b. Interpretations and agreements reached by such negotiations shall take the form of written agreement or amendment thereto. If the written agreement conflicts with other personnel rules and procedures, the agreement shall prevail.
- c. Any employee of the Union or his designated representative has the right to discuss with the Chief of Police (Chief) or Employer the terms of his employment or working conditions but no individual agreement shall be made between the Chief and said employee which violates the terms of any personnel memoranda issued by the Chief as a result of the negotiations with Union or that will violate the terms of this Agreement or any amendment thereto.

Section 3. Time spent by designated representatives of the Union in negotiations with Employer shall not be deducted from the employee's pay if the negotiations are held during normal working hours of said designated representatives.

ARTICLE 6 JOB CLASSIFICATION AND SALARY SCHEDULES.

Section 1. Employees will be compensated pursuant to attached exhibit "A".

Section 2. The salaries and wages of employees shall be paid bi-weekly on Friday of the appropriate week.

Section 3. An employee will be given copies of all documents placed in said employee's personnel file within ten (10) days of the time any such document is placed therein, if requested.

Section 4. Each employee will be entitled to review his personnel file upon request to the Police Chief and Human Resources

ARTICLE 7
HOURS OF WORK/DUTY.

Section 1. The Police Chief, at his discretion, may set the work period for employees to a fourteen (14) day period. This period will consist of seven (7) twelve (12) hour days for Police Officers and five (5) eight (8) hour days for Communication Specialists. The regular work day (shift) will consist of twelve (12) hours for Police Officers and eight (8) hours for Communication Specialists, normally worked consecutively, except for meals and similar authorized interruptions. All regular employees are subject to call twenty-four (24) hours a day, seven (7) days a week, up to thirty (30) minutes shall be allowed for lunch period. One twenty (20) minute break will be allowed during each twelve (12) hour shift. Two (2) fifteen (15) minute breaks will be allowed during each ten (10) hour shift.

Section 2. Police officers and communication specialists who work between the hours of 1800 and 0600 shall receive a shift differential of \$0.30 per hour for all hours actually worked during this period. This shift differential will be included to calculate the overtime rate for overtime hours worked between the hours of 1800 and 0600.

Section 3. At all times, there shall be a ranking Supervisor on duty.

Section 4. Call Back Rate of Pay: Members recalled to duty because of an emergency shall be paid at a rate of time and one-half (1 ½) for the actual time worked, but not less than two (2) hours of pay at the rate of time and one-half (1 ½). If an employee is called in prior to the start of their shift, they will be paid time and one-half (1 ½) for actual time worked in conjunction with the start of their scheduled shift.

Section 5. Training: Mandatory In-Service Training which is in addition to the employee's regular shift will be paid at time and one-half (1 ½) in compensatory time or overtime pay at the employee's option for a minimum of two hours. However, if the employee's training time is one hour before or after the employee's regular shift, then the employee will be compensated for one (1) hour of overtime pay or compensatory time in conjunction with the start or end of their shift.

Voluntary In-Service Training outside the employee's regular shift will be paid at straight time in compensatory time.

A Police Officer that is required to participate in training during their normal shift and that training exceeds nine (9) hours (inclusive of travel time) shall be credited with having worked their twelve (12) hour shift.

Section 6. Exchanging Hours: The Chief of Police or the officer in charge may grant the request of any two members of the Police Department to exchange hours or days off.

Section 7. Shift Bids: Officers may be allowed to bid shifts by seniority twice annually for all classifications. Specialty positions such as Patrol Training Officers and K-9 Officers may

have reserved positions based upon seniority. The Chief of Police reserves the right to designate specialty positions on each shift to ensure the proper distribution of personnel.

Bidding for the following calendar year shall occur beginning March 1st and September 1st of each year with assignments being announced and awarded on March 16th and September 16th. Officers will begin their chosen shift on the first day of the first pay period in January of each year.

The Chief of Police or his designee will provide, when possible, a 30 day notice to any officer whose regular schedule is adjusted for the needs of the department except in cases of emergencies such as loss of personnel causing a shift shortage, natural disaster or other unforeseen circumstances.

Employees may voluntarily accept a change in their schedule before the 30-day notice.

In the event a vacancy expected to be longer than 30 days exists, officers required to work a shift they did not bid, the vacancy will be offered on the basis of seniority first, with the least senior officer being involuntarily assigned, whenever possible, from his/her bid assignment. The officer filling this vacancy shall retain the right to choose their days off based upon their seniority which may include bumping less senior officers from their days off upon filling the vacancy for 30 days.

Officers, with the permission of the Chief of Police or his designee, may voluntarily trade shifts after bidding has been concluded during the 6 month period; however, they will inherit the other officer's days off regardless of seniority. No bumping shall occur as the result of voluntary trades.

Section 8. Work Schedule: The work schedule as established shall not be changed, except in times of emergency. The Chief of Police, at his discretion, may institute new types of scheduling after giving the Union thirty (30) days' notice of such a change and allowing officers to bid shifts on the new schedule. The Chief of Police shall not initiate more than three (3) such schedule changes in a twelve (12) month period unless an emergency exists or the Union agrees to additional schedule changes.

Section 9. K-9 Officers: Officers are allotted 1 hour per day worked to care and maintain the K9. To compensate for this time, officers appointed as K9 officers will be credited with seven (7) hours straight pay per pay period to care for the animal known as at-home care. When requesting time off, the K9 handler will request time based on 11 hour scheduled days.

If the officer takes vacation and is unable to care for the K9 during the vacation, another officer will be asked to take care of the K9. The original K9 handler will not receive the at-home care and that will be paid to the officer caring for the K9.

ARTICLE 8 OVERTIME.

Section 1. The Police Chief, at his discretion, shall call the necessary number of people to report on duty on an overtime basis.

Section 2: Officers assigned to work 2,184 hours annually, agree overtime shall not be compensated or accrued until working 84 hours in a pay period which is 14 calendar days.

Section 3. Dispatchers assigned to work 2080 hours annually, agree overtime shall be compensated when working more than 40 hours in a week.

Section 4: For the purpose of defining the term “working”, vacation, holiday and comp time will be counted as hours worked for purposes of determining overtime. Specifically, sick pay, casual days and bereavement leave are not included in computing “working” time.

Section 5: Employees may choose to be credited with compensatory time in lieu of overtime.

Section 6. All overtime will be kept in roll call and read at roll call by Sergeants until the overtime has been worked. All overtime will be posted (except for emergencies or for the 96-hour exemption) in the book and left blank for the allotted 72 hour period for officers to bid/bump per the contract.

The overtime will remain open for another 24-hour period for any sworn personnel to sign up.

The 96 hour exemption means “If there is less than 96 hours until the posted overtime is due, then the Sergeant will immediately order officers to work the overtime starting with the junior officer.”

If no bargaining unit employee claims the overtime or extra duty, supervisory and command personnel may work the overtime or extra duty.

In the event no supervisory or command staff volunteer for work after the 96-hour period, (whenever possible) during roll call, the Sergeant will fill any spots not voluntarily signed up for by ordering officers to work the assigned overtime. The Sergeant will order from the most junior officer to the most senior officer until all spots are filled. Officers present at roll call may not request certain spots by seniority. All remaining open spots will be assigned in this same manner. Overtime assignments are not shift specific.

Any officer that is ordered to work overtime may not take that day off without giving a 7-day notice. The officer must take off the entire shift.

In the event there is less than 96 hours until the posted overtime is due, then the Sergeant will immediately order officers to work the overtime starting with the junior officer and working through the Seniority list accordingly.

Once any officer is ordered to work the overtime, it is their responsibility. Any officer ordered may find a replacement to work for them and must notify the posting Sergeant of any changes.

When posted overtime is voluntarily split, during the 72 hour period, by two officers, officers may bump other officers based upon seniority. When a shift is split, a junior officer may bump a senior officer if the junior officer is willing to work the entire shift and only half of the shift was covered. Additionally, a senior officer may bump a junior officer or officers splitting the shift, meaning the senior officer may bump either the front half of the shift, the back half of the shift, or all of the shift. **NO BUMPING IS ALLOWED AFTER THE 72 HOUR PERIOD.**

Section 7. Employees who, as a result of performing their official duties, who are required to appear as witnesses in courts of law (civil or criminal) while not on duty will receive a minimum of two (2) hours of overtime pay or compensatory time, to be the employees choice; however, if the employee's court time is less than one (1) hour prior to or after the employee's regular shift to work, then the employee will be compensated for one (1) hour in conjunction with the start or end of their shift.

Section 8: Specialty Positions Overtime - Employees in special assignments or possessing specialized skills shall fill the overtime needs for their specific assignment unless deviations are approved by their immediate supervisor. The Department shall not be obligated to post such overtime or award it by seniority as stated in Article 18, Section 2.

Personnel in special assignments may sign up for and work patrol shift overtime provided such work does not interfere with their normal assignment and duties.

Section 5: Extra Duty - Extra duty assignments are those which by nature are typically paid for by outside entities and are normally considered "voluntary" in nature. Available jobs will be posted for at least 72 hours prior to the work if possible. Seniority shall be the determining factor on which officers shall be awarded the work. After posting has been up for the 72 hour period, officers may sign up on a "first come first serve basis".

When extra duty overtime is voluntarily split, during the 72 hour period, by two officers, officers may bump other officers based upon seniority. When a shift is split, a junior officer may bump a senior officer if the junior officer is willing to work the entire shift and only half of the shift was covered. Additionally, a senior officer may bump a junior officer or officers splitting the shift, meaning the senior officer may bump either the front half of the shift, the back half of the shift, or all of the shift. **NO BUMPING IS ALLOWED AFTER THE 72 HOUR PERIOD.** After 72 hours, Officers with less seniority shall not be bumped by more senior personnel. Deviations with approval from the Chief of Police or his designee from the 72 hour bidding period may occur when the entity requesting and paying for the extra duty officers requests officers in specific assignments or officers who possess special skills. For example, the High

School always desires that the School Resource Officers work extra duty assignments at school dances and sports events. The assignment of such an officer when requested by a contracting agency shall not violate Article 18, Section 2.

Entities requesting and paying for extra duty officers, may request that specific officers are prohibited from working the Entities' assignment with justification being made to the Chief of Police.

Extra Duty Overtime in which officers may volunteer shall be paid at a minimum of two (2) hours or the actual hours worked.

Extra Duty Overtime in which officers are ordered to work shall be paid at a minimum of three (3) hours or actual hours worked. City council assignments are excluded from this minimum.

The officers agree to the minimums above so long as that it is equal to the amount being billed by the City. Should the City bill **and receive payment from** an entity for more hours than the officer worked, the officer working the assignment will be paid for hours equivalent to those the entity was billed.

If no bargaining unit employee claims the overtime or extra duty, supervisory and command personnel may work the overtime or extra duty.

ARTICLE 9 RECOGNIZED HOLIDAYS.

The following are declared to be recognized holidays for employees covered by this Agreement. Recognized holidays shall at all times be the same as those given to other employees for the City and said holidays are as follows:

1. New Year's Day
2. Martin Luther King Day
3. President's Day
4. Memorial Day
5. Independence Day
6. Labor Day
7. Veteran's Day
8. Thanksgiving Day
9. Day after Thanksgiving
10. Christmas Day
11. The day before or after Christmas as determined by the mayor.

- a. Police Officers shall receive 132 hours of holiday pay and Communication Specialists shall receive 88 hours of holiday pay on July 1st of each year for all recognized holidays in the upcoming year.
- b. In addition to receiving holiday pay, employees who work on Thanksgiving Day, Christmas Day, New Year's Day and Independence Day shall receive one and one-half times their regular hourly rate for all hours worked.
- c. There shall be no compounding of overtime should an employee be called into work on their regular day off.

- d. Employees will be paid holiday pay for all hours worked on holidays referenced above (b).
- e. Holiday pay not used by June 30th shall be forfeited.
- f. Employees who terminate their employment (either voluntarily or involuntarily) will have their pay adjusted accordingly based upon the number of holidays which have passed during the employee's employment and how many are remaining in the fiscal year.
- g. Employees who are hired after July 1st of each year will have holidays prorated based on the number of holidays that they are employed during that year.
- h. Time and a half pay for holidays is applicable only to the Patrol Division and Communication Specialists.

ARTICLE 10
VACATION.

Section 1: Employees will start accruing vacation on their hire date. Employees will accrue according to the schedule below. Increases in accrual will take place on the day the employee reaches that length of service day. For example, on the 4 years of service anniversary day for an officer, employee will then start to accrue at the 4.85 hours per pay period rate.

Police Officers (working 2184 hours per year):

| | | |
|----------------------|---------------------|---------------------------|
| 0-3 years of service | 84 hours (2 weeks) | 3.24 hours per pay period |
| 4 years of service | 126 hours (3 weeks) | 4.85 hours per pay period |
| 11 years of service | 168 hours (4 weeks) | 6.47 hours per pay period |
| 19 years of service | 210 hours (5 weeks) | 8.08 hours per pay period |

Communication Specialists (working 2080 hours per year)

| | | |
|----------------------|---------------------|---------------------------|
| 0-3 years of service | 80 hours (2 weeks) | 3.08 hours per pay period |
| 4 years of service | 120 hours (3 weeks) | 4.62 hours per pay period |
| 11 years of service | 160 hours (4 weeks) | 6.15 hours per pay period |
| 19 years of service | 200 hours (5 weeks) | 7.69 hours per pay period |

Section 2. Employees may accumulate accrued vacation not to exceed the amount earned in one and one-half (1 ½) years. Any unused vacation days exceeding the one and one-half (1 ½) times will be added to that of the employee's sick accrual.

Section 3. An employee who leaves the employment of the City and after giving two (2) weeks' notice of such termination of employment shall be compensated for all vacation accrued to date of separation.

Section 4. All accrued vacation shall be paid to the family or estate of a deceased employee who has passed away while being in the employ of the Employer, but it is not required that said death have occurred on the job.

Section 5. Vacation/Holiday/Casual Requests & Bidding - The nature of the work and the operation of the Ottumwa Police Department make it necessary to limit the number of employees on vacation/holiday/casual leave at the same time.

- Police Officers' requests for vacation/holiday/casual are shift specific.
- Dispatcher requests for vacation/holiday/casual are bid across the entire DataCom Unit. Seniority as it applies to bidding for vacation shall be based upon the employee's most recent date of full time employment.
- Shift bid for the following calendar year (beginning of first pay period in January) will be posted on September 1st of each year. Officers will have until September 15 to bid their shift.
- Vacation/Holiday/Casual bidding will be opened based upon seniority on March 16th and September 16th and will be open until 23:59 hours on March 26th and September 26th. Vacation bids will be awarded upon the close of the bidding process
- An employee's request for vacation/holiday/casual shall be based on seniority and priority of choice. Employees will request a first, second, and third choice for vacation/holiday/casual.
- First choice of vacation/holiday/personal time off should cover a 5-day period. Vacation will only be deducted for those days in the above period which the officer was scheduled to work.
- Any first bid not inclusive of a 5 day period will be considered invalid and that employee will forfeit their first choice of vacation/holiday/casual. All remaining choices of vacation, holiday, and casual during this period must be a minimum of one full shift.
- After all officers on the shift have submitted a bid for their first choice of time off, the senior officer will be allowed to make their second choice of vacation/holiday/casual. The remaining choices of time off will be followed in the same manner until such time all bids submitted have either been awarded or rejected.
 - For example: The senior employee will receive their first priority choice of time off. The next senior employee will receive their first priority choice of time off so long as the shift is able to maintain minimum staffing. This process will continue until all employees on the shift have been granted one period of time off. Once all employees have been granted a period of vacation/holiday/casual the shift supervisor will start over with the most senior officer and grant the senior officer their second choice as long as it does not conflict with other already granted time off or require the shift to fall below minimum staffing. The process will continue until all employees have been granted a second vacation period. This process will be repeated again until all employees have been granted three vacation choices or those bids have been rejected. Only one officer will be allowed vacation/holiday/casual off at a time during the bidding period.

- In the event an employee cancels a granted vacation period the employee forfeits their ability to choose a vacation date which bumps another employee's granted vacation period. Should a cancellation occur, officers on that shift shall be notified of the cancellation and other officers may request the time off and it shall be awarded by seniority in the first 7 days after the cancellation and on a first come, first serve basis thereafter.

Section 6. One (1) week notice must be given to the Chief or his designee before taking any vacation, unless in an emergency situation.

Section 7. Vacation requests outside of the bidding process will be based upon a first come, first serve basis and may be submitted at any time but will not be approved or rejected earlier than 60 days prior to the date of the event. Likewise, vacation requests must be given to the Chief or his designee at least 7 days in advance, unless in an emergency situation. Requests for leave between the 60 – 7 day window will be approved or rejected within 72 hours.

Section 8. Consecutive vacation days off that run over into the following year will be granted as the bid in the previous year. Ex. December 20th through January 10.

Section 9. Employees will request exact dates of vacation, so in the event the employee is transferred to another shift those dates requested are granted and days off do not affect their vacation time. Actual hours used by the employee will be deducted from the employees accrued time balance.

Section 10. A paid leave of absence is considered a twenty four hour period. **The twenty-four hour period begins at the employee's normal work starting time and ends 24 hours later.** Whenever an employee is called back from paid leave or a regular day off running consecutive to their approved paid leave of absence the employee must choose one of two options:

Option 1. The employee will receive time and one half (1 ½) for all hours worked in addition to the pay being received from the leave of absence or:

Option 2. The employee will receive time and one half (1 ½) for all hours worked and credited back the employee's original hours of leave for the day.

Officers on paid leave of absence shall notify the supervisor requesting the officer to report for duty that they are on a paid leave of absence, including if they are on regular days off in conjunction with a paid leave of absence. An employee who fails to notify a supervisor that they are on paid leave of absence or regular day off in conjunction with the paid leave will forfeit the payment of the paid time off for that period or crediting of paid time off.

This section shall apply only in the event of an actual call in requiring the employee to report for work. Instances such as court, depositions, etc. are exempt from this section.

Section 11. Any employee serving as communication specialist who wishes to take vacation, outside of the bid process outlined above, which would create overtime or the displacement of another employee to cover their shift must do so with at least a 10 day advance notice. Leave of absence requests may be granted as long as the minimum staffing requirements are met as deemed appropriate by the Chief of Police.

- In the event 2 Datacom employees elect vacation during the same period, the Communications Supervisor may temporarily displace an employee from their regular shift to the shift in need of coverage.
- Displacement shall occur with the most senior employee being offered a voluntary schedule adjustment to cover the shift. In the event no one voluntarily adjusts their schedule, the least senior and available employee will be displaced and shall be given 7 days advance notice unless in the case of an emergency.

ARTICLE 11 SICK PAY

SICK PAY.

Section 1. All regular or probationary Police Officers (working 2184 hours per year) earn sick pay at the rate of 11.08 hours per pay period. All regular or probationary Communication Specialists (working 2080 hours per year) earn sick pay at the rate of 7.39 hours per pay period. Sick pay may be granted in hourly increments only for absence from duty due to personal illness, legal quarantine, or casual pay.

Section 2. If any employee takes more than three (3) consecutive days sick pay in any sixty (60) calendar day period, the Employer may require a medical certification before employee may return to work, said certification to be at the employee's expense. Failure to furnish medical certification may result in the Employer beginning disciplinary procedures.

Section 3. Sick pay may be granted at the employee's request at the discretion of the Chief of Police or his designee for serious illness in the immediate family. Immediate family shall be defined pursuant to the City Personnel Policies. Additional persons may be added to this section at the discretion of the Chief of Police because of death or sickness.

Section 4. 4 days annually (48 hours for Police Officers working 2184 hours per year OR 36 hours for Communication Specialists working 2080 hours per year) may be used as casual sick days to be taken with the authorization of the Department Head of the Employer to be deducted from employee's sick leave

Section 5. Employees reporting off sick must do so as soon as possible by contacting the supervisor currently on duty.

Section 6. No sick pay shall be paid to employees for injuries incurred or received while the employee is working on the job of another employer, (moonlighting), who pays sick leave.

Section 7. Any employee injured while on duty for the City shall continue to accrue full benefits while on injury leave or until placed on temporary disability by the Police Pension Board, subject to State law. All benefits accrued before being placed on temporary disability will be frozen until a final disposition is made.

Section 8. Any employee injured on the job must report it within twenty-four (24) hours of when it happens. The Employer requires the right to designate the physician if so desired, to verify the certification of the employee's physician and the extent of their injuries.

Section 9. The first payroll in December of each year, each employee shall be paid for 25% of accrued sick pay according to the following schedule:

- Police Officers working 2184 hours per year – Hours in excess of 2016, up to a maximum of 50 hours. Employee's sick accrual will be reduced to 2016 hours.
- Communication Specialists working 2080 hours per year – Hours in excess of 1920, up to a maximum of 48 hours and the employee's sick accrual will be reduced to 1920 hours.

November 1st of each year will be the date used for determining payment.

Section 10. It is understood and agreed between the parties hereto that once an employee has exhausted their paid leave, they shall be granted leave without pay for a period of up to six months from the date the employee exhausted all paid time off. Seniority shall be frozen on the date accrued paid time off is exhausted. The City Administrator has the discretion to extend this period for up to an additional six months.

MATERNITY/PATERNITY LEAVE:

Section 11. Employees may elect to take time in accordance with the Family Medical Leave Act and applicable State Law. Maternity/Paternity Leave is not deducted from dependent sick leave. Please review City Leave of Absence Policy for more information.

ARTICLE 12 LEAVE WITH PAY.

Section 1. The Chief may authorize leave with pay, which will not be charged to vacation or sick accruals, for the following reasons:

- a. For appearance in court, either as a member of the jury or when required to appear as a witness; however, if the employee instigates the court proceedings, then said employee shall not be paid. When an employee appears during regular working hours and receives full pay from the City, any pay that the employee might receive from the Court, except for mileage, will be turned over to the Police Department.
- b. For attendance at an official meeting where the good of the City is involved, but within the budget allowance for this purpose.

Military Leave:

- c. For active duty in any branch of the armed forces of the United States or the State of Iowa, for the period of such active State or Federal services during the first thirty (30) days of such leave of absence in conformity with Chapter 29A.28 of the Code of Iowa, as amended.

Bereavement Leave:

- d. Employees may be granted bereavement leave in accordance with the following schedule and shall not have this leave deducted from any accrual banks:
 - a. Up to five (5) days for the death of a spouse, child or stepchild.
 - b. Up to three (3) days for the death of a parent, stepparent, sibling, grandchild or employee's own grandparents.
 - c. Up to one (1) day for the death of a father/mother-in-law, brother/sister-in-law, son/daughter-in-law or spouse's grandparents.
 - d. The Police Chief, at his discretion may extend bereavement leave so long as the extension is deducted from accrued leave excluding sick leave and may be unpaid time off (if no other paid leave is available.)

Section 2. All leave with pay except those related to sickness, injury and death must be applied for in advance.

Section 3. Any employee on paid leave in excess of 90 consecutive days will not continue to accrue paid leave.

Compensatory Time:

- a. Compensatory time shall be granted with a 3-day advance notice so long as the minimum staffing as deemed appropriate by the Chief is maintained.
- b. Additionally, compensatory time may be granted with less notice so long as the minimum staffing as deemed appropriate by the Chief is maintained. In this event, officers will be expected to report for roll call and once minimum staffing has been confirmed, the officer will then be released on leave.
- c. Employees hired prior to July 1, 2016 may carry over the FLSA maximum amount of 480 hours. Effective July 1, 2016, new police department hires may accumulate up to a maximum of 150 hours of compensatory time. However, no more than 40 hours may be carried over after November 1st of each year. As of November 1st of each year, all compensatory time over 40 hours will be paid to the employee in the first full pay period of November.

ARTICLE 13
LEAVE WITHOUT PAY.

Section 1. A regular employee may be granted leave without pay for a period not to exceed one (1) year for good and sufficient reasons, which are considered to be in the best interest of the City. The City Council may extend such leave for good and sufficient reasons.

Section 2. An employee designated by the Union to represent it at an International, State or District meeting, which requires this absence from duty, shall be granted the necessary time off without pay. Under no event shall the number of employees exceed four (4).

Section 3. No person shall be discriminated against because of military service (including National Guard) requirements; however, every person required to attend weekend drills shall notify the Employer in advance so employee's days off can be scheduled to fall on days of said drills or said employee shall make arrangements with the military unit to schedule drill on employee's days off.

Section 4. An employee on unpaid leave of absence shall receive no compensation, shall not accrue seniority, and shall not earn or collect vacation, sick pay, or other benefits.

ARTICLE 14
INSURANCE.

Section 1. Contribution Rate: The City shall contribute 90% of the premium for the coverage selected and the employee shall contribute 10% of the premium.

The Employer shall also provide insurance to the surviving spouse and family of an Employee; said coverage to be subject to the same terms and conditions as active members. All coverage shall cease if surviving spouse remarries, is covered by another insurance program OR 1 year since the employees passing; whichever comes first. The City will provide insurance coverage for employee's children in compliance with State and Federal Law.

Section 2. Plan Design: The employees covered by this contract shall be eligible to participate in the health insurance plan design that has been implemented for all other employees of the City.

Section 3. The City will pay the premium required in Section 1 for the first one (1) month following an employee being laid off.

Section 4. Cadillac Tax Liability – Should the City's health insurance plan become classified as a Cadillac plan subject to tax under the Affordable Care act, the employer reserves the right to open the contract as it relates to the Insurance place structure at the discretion of the City.

Section 5. Life Insurance: The Employer shall provide life insurance for all employees in the amount of their annual base salary rounded up to the nearest \$1,000 during their employment.

ARTICLE 15 EQUIPMENT.

Section 1. No person employed by the City shall be forced to use equipment that is in an unsafe condition because of mechanical faults or that does not meet legal safety requirements of such equipment. Employees shall report the unsafe condition of any equipment immediately to their appropriate supervisor.

Section 2. The City will reimburse an employee for personal property that is damaged while the employee is performing on-the-job duties for the City, provided the damage occurred on duty and could not have been avoided to the satisfaction of the City. The maximum amount an employee may be reimbursed is up to \$150.00 per damaged item for the actual cost to replace such item, except regular prescription glasses which an employee may be reimbursed up to \$500. Damage must be reported to the officer-in-charge prior to the end of the employee's shift in which the damage occurred on. All employees are required to exercise necessary caution to prevent the loss or damage to personal property.

Section 3. The City will furnish all new officers hired on the Ottumwa Police Department with complete uniforms and equipment as specified by the Police Department and shall provide replacement uniforms and equipment as may be needed to all active duty personnel.

Section 4. The City will reimburse patrol officers up to \$200.00 per year for approved footwear and optional approved Police equipment. Payment shall be made to the officer within thirty (30) days after submission to department. The City will reimburse investigators up to \$200.00 every six months for approved clothing and optional approved Police equipment while serving as an investigator.

Should an employee voluntarily leave employment within six (6) months of receiving their reimbursement, the employee shall reimburse the City for any monies received.

ARTICLE 16 DISCIPLINARY PROCEDURES.

Employee Representation: In all matters of discipline and discharge, except in the case of informal reprimand, the employee may be represented by the Union and shall be subject to the grievance procedures of Article 17.

Refer to Police Policy and Procedure Manual, which will be on file in the Human Resources Office.

ARTICLE 17
GRIEVANCE PROCEDURES.

Grievance and Arbitration Procedures: Any grievance or dispute which may arise between the parties, including the application, meaning or interpretation of this Agreement, shall be settled in the following manner:

Section 1. A grievance is defined as a timely filed claim by an employee covered by this Agreement which alleges that there has been a violation of a specific and express provision of this Agreement by the City.

Section 2. Should an employee claim a grievance, it shall be processed in the following manner:

- Informal Step: The employee shall first discuss the problem with the immediate supervisor in an attempt to resolve the problem informally within seven (7) calendar days of the occurrence or alleged violation. The immediate supervisor shall respond to the Employee's concerns within seven (7) calendar days of being made aware of the occurrence or alleged violation. If the problem is not settled to the employee's satisfaction, the following procedure shall be used.
- Step One. An employee who claims a grievance shall reduce the grievance to writing by giving and signing a statement of facts, what is the issue, what section of the contract was violated, and what remedy the employee is seeking. The written grievance must be submitted to the Division Commander no later than ten (10) calendar days after the immediate supervisor's response. The Division Commander shall give a written answer to the aggrieved employee within ten (10) calendar days after the grievance is presented to him.
- Step Two. If the grievance is not settled in Step 1 and the grievant wishes to take the grievance forward, the grievant must submit the signed grievance to the Chief or his designee within seven (7) calendar days after receipt of the Step One response. The Chief will give a written answer to the aggrieved employee within fourteen (14) calendar days after the grievance is presented to him.
- Step Three. If the grievance is not settled in Step Two, the grievant may submit the grievance to the City Administrator or designee within ten (10) calendar days of the receipt of the Chief's written answer.
 - If requested by the grievant, the City Administrator will meet with the grievant who may, at his or her option, be accompanied by a Union representative, at a time mutually agreeable to the parties, and if a settlement is not reached, the City Administrator or his designee will provide a written answer to the grievant, with a copy to the Union, within fourteen (14) calendar days following such a meeting.

An employee may choose to exercise their rights under the grievance procedure or the Civil Service Commission (Chapter 400 of the Code of Iowa, as amended), but not both.

- Step Four. If the grievance is not settled in accordance with the foregoing procedure, the Union and the grievant may submit the grievance to arbitration within fourteen (14) calendar days after the receipt of their answer to Step Three. Said notice must be signed by both the grievant and the authorized representative of the Union. Within fourteen (14) calendar days after receipt of the notice parties shall attempt to select a mutually agreeable arbitrator. In the event the parties are unable to agree upon an arbitrator, either may, within twenty-one (21) calendar days after receipt of the notice, request the Public Employment Relations Board to submit a panel of seven (7) arbitrators. Each party retains the right to reject one panel in its entirety and request that a new panel be submitted. Within ten (10) calendar days after receipt of the panel, a coin flip shall determine which party shall strike a name from the list, and the seventh and remaining person shall act as the arbitrator.

The decision of the Arbitrator shall be final and binding on the parties, and the Arbitrator shall be requested to issue their decision within thirty (30) calendar days after the conclusion of the hearing.

The reasonable expenses, fees, and costs of the Arbitrator shall be shared equally by the parties. Any other expenses shall be paid by the party incurring them, and each party shall be responsible for compensating its own representatives and witnesses.

Section 3. All grievances shall be presented, discussed and processed at a time mutually agreed to. Meetings outside of the officer's normal work shift shall not be compensated.

Section 4. If a grievance is not presented or processed within the time limits set forth herein, it shall be considered waived and the employee shall be barred from further pursuit of the grievance. If a grievance is not appealed to the next step within the specified time limit, it shall be considered settled on the basis of the City's last answer and the grievant shall be barred from further pursuit of the grievance. The failure of the City's specified representative to answer a grievance within the specified time limit shall be deemed a denial of the grievance at that step which may then be timely appealed to the next step.

Section 5. If any claim or complaint is filed in any form other than under the grievance procedure of this Agreement, then the City shall not be required to process the same or similar claim or set of facts through the grievance procedure.

Section 6. An employee may be represented at any stage of the grievance procedure by a Union representative.

ARTICLE 18
SENIORITY – LAY OFF – JOB ABOLISHMENT.

Section 1. All vacancies and promotions shall be made in compliance with Chapter 400 of the Code of Iowa, as amended.

ARTICLE 19
MISCELLANEOUS.

Section 1. Employer will reimburse the employee for actual cost of any license or permit with the exception of regular driver's license and/or chauffeurs license that the Employer requires of the employee. All members of the Ottumwa Police Department are required to possess and maintain a valid Iowa Driver's License.

Section 2. If the City requires an employee to attend any out-of-town school, meeting, or training session, the City shall pay for the employee's meals, lodging, and transportation costs in accordance with the City of Ottumwa Personnel Policy Manual and without any loss in wages by the employee.

Section 3. The City and the Union shall cooperate fully in matters of safety, health and sanitation affecting the members.

Section 4. The City agrees not to give out the telephone numbers or addresses of any member of the Ottumwa Police Department to the public.

Section 5. The City will furnish a copy of the contract to all members of the Union.

Section 6. Employees will receive \$25.00 per month (known as Longevity Pay) for each five (5) years of service.

Section 7. Representatives of the Union and the City, upon request of either party, shall meet bimonthly to discuss labor/management related issues. After full discussion of the issues within the Department, the parties may request the City Administrator to attend such meetings.

Section 8. Officers and Communications Specialists will receive an additional five (5) percent hourly pay (including longevity) for hours spent serving as a Field Training Officer, Police Training Officer, or similar training position. This additional pay for hours spent serving as a training officer will be included to calculate the overtime rate, if applicable for that pay period.

ARTICLE 20
MANAGEMENT RIGHTS CLAUSE.

It is recognized that, except as expressly stated herein in this Agreement, the City shall retain whatever rights and authority as are necessary for it to operate and direct the affairs of the City in all of its various aspects, including, but not limited to, the right to direct the working

forces; to plan, direct and control all the operations and services of the City; to determine the methods, means, organizations and number of personnel by which such operations and services are to be conducted; to assign and transfer employees; to schedule working hours and to assign overtime; to determine whether goods or services shall be made or purchased; to hire, promote, demote, suspend, discipline, discharge or relieve employees due to lack of work or other legitimate reasons; to make and enforce reasonable rules and regulations; and to change or eliminate existing, methods, equipment or facilities as set out in Section 20.7 of the Code of Iowa, as amended, except as hereinabove expressly stated in this agreement.

ARTICLE 21
EMPLOYEES RIGHTS CLAUSE.

It is recognized that, except as hereinabove expressly stated in this Agreement, Employees shall retain whatever employee rights and authority as granted in Section 20.8 of said Code of Iowa, as amended.

ARTICLE 22
AMENDMENT.

This Agreement may be amended upon mutual agreement of the parties hereto and as permitted by law. Appropriate amendment shall be executed by the parties of this Agreement upon appropriate Resolution of the Employer and ratification of the Union.

ARTICLE 23
SAVINGS CLAUSE.

Should any article, section or portion thereof this Agreement be held unlawful and unenforceable by any Court of competent jurisdiction, such decision of the Court shall apply only to the specific article, section, or portion thereto directly specified in the decision; upon the issuance of such a decision, the parties agree immediately to negotiate a substitute for the invalid article, section or portion thereof.

CITY OF OTTUMWA

OTTUMWA POLICE UNION
TEAMSTER'S LOCAL #238

BY: Richard W. Johnson
Richard W. Johnson, Mayor

BY: Richard Hoffman
Richard Hoffman, Business Representative

Date: 6/20/23

Date: 5-23-2023

BY: R-R-186
Richard Ritz, Chief Steward

Date: 5-24-23

BY: Jordan Staton
Jordan Staton, Assistant Steward

Date: 5-24-23
William Bishop, Assistant Steward

BY: William Bishop
Jesse Case, Secretary/Treasurer

Date: X

ATTEST:
Christina Reinhard
Christina Reinhard, City Clerk

Date: 6/20/2023

CITY OF OTTUMWA

BY Richard W. Johnson
Richard W. Johnson, Mayor

Date: 6/20/23

OTTUMWA POLICE UNION
TEAMSTER'S LOCAL #238

BY: _____
Richard Hoffman, Business Representative

Date: _____

BY: _____
Richard Ritz, Chief Steward

Date: _____

BY: _____
Jordan Staton, Assistant Steward

Date: _____
William Bishop, Assistant Steward

BY _____
Jesse Case, Secretary/Treasurer

Date: _____



ATTEST:
Christina Reinhard
Christina Reinhard, City Clerk

Date: 6/20/2023

Communication Specialist

The Chief of Police shall have the discretion to start operators currently NCIC certified on the wage up to Step C depending upon the applicant's previous experience and qualifications. Operators may be given one step on the wage scale for every 1 year of full-time experience.

Employees in Step A through Step G will remain in their respective step for twelve (12) months before advancing to the next step. Employees hired without IOWA/NCIC certification shall start in the Trainee Step and will move to Step A upon receiving certifications.

Raises and pay adjustments will be effective on the actual due date.

| | Market Adjustment 7/1/2023 | 7/1/2024 | 7/1/2025 |
|---------|---------------------------------------|-----------------|-----------------|
| | | +6% | +6% |
| Trainee | \$20.77 | \$22.02 | \$23.34 |
| A | \$21.24 | \$22.51 | \$23.87 |
| B | \$21.72 | \$23.02 | \$24.40 |
| C | \$22.22 | \$23.55 | \$24.97 |
| D | \$22.72 | \$24.08 | \$25.53 |
| E | \$23.24 | \$24.63 | \$26.11 |
| F | \$23.77 | \$25.20 | \$26.71 |
| G | \$24.31 | \$25.77 | \$27.31 |
| H | \$24.87 | \$26.36 | \$27.94 |

EXHIBIT A
POLICE DEPARTMENT – WAGE SCHEDULE

The Chief of Police shall have the discretion to start officers who are currently ILEA certified on the wage scale up to step 3 depending upon the applicant’s previous experience and qualifications. Officers may be given one step on the wage scale for every 2 year of full-time experience.

Raises and pay adjustments on the anniversary date of hire will be effective on the date of the anniversary.

| | +6% | | | +6% | | | +6% | | |
|----------------|-----------------|----------|--|-----------------|----------|--|-----------------|----------|--|
| | 7/1/2023 | | | 7/1/2024 | | | 7/1/2025 | | |
| Start | 23-0 | \$ 28.20 | | 24-0 | \$ 29.89 | | 25-0 | \$ 31.68 | |
| 1 year | 23-1 | \$ 28.85 | | 24-1 | \$ 30.58 | | 25-1 | \$ 32.41 | |
| 2 year | 23-2 | \$ 29.59 | | 24-2 | \$ 31.36 | | 25-2 | \$ 33.24 | |
| 3 year | 23-3 | \$ 30.42 | | 24-3 | \$ 32.25 | | 25-3 | \$ 34.18 | |
| 4 year | 23-4 | \$ 31.37 | | 24-4 | \$ 33.25 | | 25-4 | \$ 35.24 | |
| 5 year | 23-5 | \$ 32.42 | | 24-5 | \$ 34.36 | | 25-5 | \$ 36.43 | |
| 6 year | 23-6 | \$ 33.59 | | 24-6 | \$ 35.61 | | 25-6 | \$ 37.75 | |
| 7 year | 23-7 | \$ 34.90 | | 24-7 | \$ 37.00 | | 25-7 | \$ 39.22 | |
| 8 year or more | 23-8 | \$ 36.36 | | 24-8 | \$ 38.54 | | 25-8 | \$ 40.85 | |

received
6/9/23 3:40pm

CITY OF OTTUMWA
Staff Summary

**** ACTION ITEM ****

Council Meeting of : Jun 6, 2023

Administration
Department

Barbara Codjoe
Prepared By
Barbara Codjoe
Department Head



City Administrator Approval

AGENDA TITLE: Resolution #93-2023 - Approve updates to Personnel Policy

Public hearing required if this box is checked.

RECOMMENDATION: Pass and adopt resolution #93-2023

DISCUSSION: Changes in the personnel policy are outlined on the next page and highlighted in the actual policy.

Source of Funds: N/A

Budgeted Item: Budget Amendment Needed:

Article 1 - General Provisions

Add "Personnel policies and handbooks do not address each and every situation. There may be work rules that are not set forth in the handbook. Employees are expected to abide by all work rules, performance standards, supervisor directives, or conditions of employment once they receive notice of them either orally or in writing."

Article 3 - Equal Employment Opportunity

Added who to contact for more information.

Article 10 - Benefits

Health and life insurance - Added "Please review the Insurance Policy and plan documents from our provider for further information".

Also added - Any employee who is eligible for insurance coverage under this policy and seeks to include any dependents under their plan, including a spouse, partner, and/or children, will be required to provide proof of the eligible dependent relationship. Documentation of the dependent relationship must be provided to Human Resources before the requested coverage will go into effect. Examples of documents that may be used to verify the dependent relationship can include a marriage certificate, common law affidavit with the current year 1040 tax return, or birth certificate (for child dependents). A full list of accepted documents can be obtained from Human Resources. Questions regarding dependent verification should be directed to Human Resources.

RESOLUTION NO. 93-2023

RESOLUTION APPROVE UPDATED PERSONNEL POLICIES AND PROCEDURES

WHEREAS, the City of Ottumwa, Iowa had approved a revised Personnel Policies and Procedures manual on June 2, 2020, which incorporated the current practices regarding Benefits, Employee Physical and Personnel Files as part of the document and;

WHEREAS, staff for the City of Ottumwa has reviewed the current policies regarding General Provisions, Equal Employment Opportunity and Benefits and determined the current policy does not meet the short and long term care for employees and operational needs for the employer, and;

WHEREAS, staff has drafted and revised the Personnel Policies and Procedures to meet the needs of both employee and employer and finds that approval of said policies and procedures, as revised, would be in the best interest of the City and the employees of the City, and;

NOW, THEREFORE, BE IT RESOLVED, by the City Council of the City of Ottumwa, Iowa, that the current Personnel Policies and Procedures approved on June 2, 2020 and any supplements thereafter are hereby repealed and that the attached Personnel Policies and Procedures are hereby adopted in their place with an effective date of June 20, 2023.

BE IT FURTHER RESOLVED, by the Ottumwa City Council of the City of Ottumwa, Iowa, that the Mayor and City Clerk are hereby authorized and directed to execute said resolution.

PASSED, ADOPTED and APPROVED this 20th day of June 2023.

CITY OF OTTUMWA, IOWA

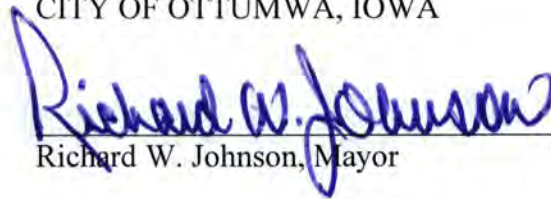
Richard W. Johnson, Mayor

ATTEST:

Christina Reinhard, City Clerk

CITY OF OTTUMWA

PERSONNEL POLICIES AND PROCEDURES

**Passed by resolution
JULY 19, 2020**

**Updated
June 2023**

Table of Contents

| | |
|---|----|
| Article 1 – General Provisions | 3 |
| Article 2 – Employment At-Will | 4 |
| Article 3 – Equal Employment Opportunity | 4 |
| Article 4 – Recruiting | 5 |
| Article 5 – Civil Service | 7 |
| Article 6 – Residency Requirements..... | 8 |
| Article 7 – Nepotism..... | 8 |
| Article 8 – Wages/Job Classifications | 9 |
| Article 9 – Hours of Work | 12 |
| Article 10 – Benefits | 13 |
| Holidays | 13 |
| Vacation..... | 14 |
| Sick..... | 15 |
| Incentive | 17 |
| Parental | 17 |
| Funeral Leave | 17 |
| Longevity | 18 |
| FLEX Spending Plan..... | 18 |
| Retirement Plans | 19 |
| Health and Life Insurance | 19 |
| Article 11 – COBRA | 20 |
| Article 12 – Employee Leave Policy..... | 21 |
| Article 13 – Military Leave..... | 21 |
| Article 14 – Harassment | 22 |
| Article 15 – Internal Investigations | 24 |
| Article 16 – Employee Assistance Program (EAP) | 25 |
| Article 17 – Accident Review | 27 |
| Article 18 – Workers Compensation & Restricted Duty Assignments | 30 |
| Article 19 – Employee Physicals & Medical Services..... | 31 |
| Article 20 – Fitness for Duty Exams..... | 32 |
| Article 21 – Personnel Files | 34 |
| Article 22 – Performance Evaluations | 36 |
| Article 23 – Access to City Administrator..... | 36 |
| Article 24 – Cybersecurity | 36 |
| Article 25 – Disciplinary Practices / Procedures..... | 37 |
| Article 26 – Grievance Procedure..... | 41 |
| Article 27 – Employee Privacy | 42 |
| Article 28 – Violence in the Workplace | 42 |
| Article 29 – Dress Code Policy | 43 |
| Article 30 – Conflicts of Interest..... | 47 |
| Article 31 – Smoking..... | 48 |
| Article 32 – Substance Abuse Policy..... | 48 |
| Article 33 – Travel..... | 52 |
| Article 34 – Separation from City Service..... | 54 |

ARTICLE 1. GENERAL PROVISIONS

The purpose of these Policies and Procedures is to establish a fair and equitable system of personnel administration that will allow for the efficient and effective public service for the City of Ottumwa.

These Policies and Procedures shall apply to all full-time and regular part-time City employees. Each department may adopt their own policies and procedures that are more stringent than these policies with approval of the City Administrator; but in no event shall they be less stringent.

In case of conflict with a collective bargaining unit agreement, the contract shall supersede these personnel policies of the City. In case of conflict with more stringent departmental rules, the departmental rules shall supersede these personnel policies of the City.

In the case of conflict with Chapter 400 of the Iowa Code (Civil Service) or any other Iowa statute or Federal Regulation, the statute or Federal Regulation shall supersede the personnel policies of the City.

These Policies and Procedures and any amendments shall become effective upon adoption by resolution of the City Council.

The City Administrator may adopt, amend, and rescind administrative policies and procedures not in conflict with these Policies and Procedures or any collective bargaining agreement as necessary for the proper administration of the City. Department heads may adopt, amend, and rescind departmental administrative policies and procedures not in conflict with these Policies and Procedures or any collective bargaining agreement, or the City Administrator directives, as necessary for proper departmental administration. A copy of all individual department policies and procedures are to be maintained in Human Resources.

These Policies and Procedures are designed to acquaint you with the City of Ottumwa and provide you with information about working conditions, employee benefits, and some of the policies affecting your employment. Personnel policies and handbooks do not address each and every situation. There may be work rules that are not set forth in the handbook. Employees are expected to abide by all work rules, performance standards, supervisor directives, or conditions of employment once they receive notice of them either orally or in writing.

Ottumwa citizens are our organization's most valuable assets. Every employee represents the City of Ottumwa to its citizens and the public as a whole. The way we do our jobs presents an image of our entire organization. Citizens will judge all of us by how they are treated with each employee contact. Our first priority should be toward the citizens of our community. Nothing is

more important than being courteous, friendly, helpful and prompt in the attention we give our community.

ARTICLE 2. EMPLOYMENT AT WILL

This manual has been prepared to advise employees of their responsibilities as an employee of the City of Ottumwa, Iowa and the many benefits and privileges they may enjoy. It is presented as a matter of information only. It is not a written contract or a legal document. While the City believes in the policies and procedures described, it is committed to reviewing them continually, and reserves the right to change or terminate any or all of them at any time.

Unless otherwise provided for in a written employment contract authorized by the Ottumwa City Council, or in a collective bargaining agreement, all employment relationships with City of Ottumwa, Iowa are at-will. At-will employees of the City of Ottumwa, Iowa are not guaranteed, in any manner, employment for any period of time. Just as the employee retains the right to terminate employment at any time, for any reason, the City of Ottumwa retains a similar right. No policy or practice of the City shall be construed to change this relationship. Only the City Council has the right to modify or change this practice, and such action must be in writing.

These personnel provisions may not be all-inclusive, are subject to interpretation by the City Administrator or designee, and represent brief summaries of City guidelines, which are subject to change without prior notice at any time at the sole discretion of the City Council. This handbook supersedes and replaces all previous handbooks and policies.

Nothing in these guidelines, creates, is intended to create, or shall be construed to constitute an express or implied contract of employment between the City and employees. No City employee can make any representation otherwise. Any representation by any City employee does not change these conditions of employment and cannot be relied upon.

ARTICLE 3. EQUAL EMPLOYMENT OPPORTUNITY

The Policy of the City of Ottumwa is to provide equal opportunity in employment to all employees and applicants for employment. No person is to be discriminated by reason of race, color, religion, creed, sex, age, veteran status, national origin, disability, sexual orientation, gender, citizenship status, familial status, political affiliation, genetic information or testing, gender identity or expression or any other legally protected status which may be protected by applicable federal or state law with respect to hiring, upgrading, transfers, recruitment advertising, recruitment, selection, placement, promotion, demotion, layoff, compensation, benefits, training, termination, and any other terms, conditions, and privileges of employment. Other protected groups include those who have been arrested but not convicted of a crime, individuals infected

with HIV, individuals who smoke outside the workplace, and individuals who are actively involved in politics or local unions.

1. Any communication from an applicant for employment, an employee, a government agency, or an attorney, concerning any equal employment opportunity matter shall be referred to the City Administrator or designee for action.
2. While overall authority for implementing this Policy is assigned to the City Administrator or designee, an effective equal employment opportunity program cannot be achieved without the support of supervisory personnel and employees at all levels. Employees who believe they are the victims of discrimination have a responsibility to promptly report this fact to their supervisor and/or the City Administrator or designee.
3. Complaints of discrimination by an employee will be handled and investigated under the City's Grievance Procedure, unless special procedures are considered appropriate, such as referral to the Iowa Civil Rights Commission or another outside investigator. All complaints of discrimination will be investigated promptly and in an impartial and confidential manner. The City prohibits retaliating against employees who engage in "protected activity" such as complaining about discrimination or harassment, or participating in an investigation. The City prohibits any form of retaliation against employees for bringing bona fide complaints or providing information about discrimination.

For further information, please contact Human Resources.

ARTICLE 4. RECRUITING

The City of Ottumwa believes that hiring qualified individuals to fill positions contributes to the overall success of the City. Each employee is hired to make significant contributions to the City of Ottumwa. The City of Ottumwa also strives to retain employees through an environment that creates opportunity and encourages advancement.

The City of Ottumwa has adopted an internal and an external posting process that may run concurrently. Positions will be posted on designated employee communication boards at each location along with electronically in UKG (the City's Human Resources Information System).

For additional information, please review policy #75 – Hiring Policy and Process.

Background Checks:

To ensure that individuals who join the City are well qualified and have a strong potential to be productive and successful employees, it is the City's policy to investigate the backgrounds and employment references of applicants. In addition, the City may conduct background investigations when employees are being considered for promotions or transfers, or in furtherance

of an internal investigation of alleged misconduct. Background investigations will be conducted at City's discretion and in accordance with federal and state law.

Motor Vehicle checks for employees who drive on behalf of the City or have required CDL licenses will be conducted annually, including required annual checks with the Federal Clearinghouse. The City relies on the accuracy of information contained in employment applications, as well as the accuracy of other data presented throughout the hiring process and during employment. Any misrepresentations, falsifications, or material omissions in any of this information or these data may result in an applicant being excluded from further consideration for employment or, if an individual has already been hired, termination of employment.

Use of Information Obtained in a Background Investigation:

Information obtained from a background investigation will be considered for employment purposes as permitted by federal and state law and in accordance with City's Equal Employment Opportunity Policy.

Information will be reviewed to determine:

- Whether false statements or material omissions were made by an individual on an application for employment or during an interview;
- Whether an applicant or employee, based on the job duties of the position in question, poses a threat to security and/or employee safety in the workplace; *and*
- The likelihood of an applicant or employee being successful and productive on the job.

For additional information, please review our Background Check Policy.

Recalling or reinstating former employees

Employees who leave service with the City due to resignation, retirement, or layoff MAY be eligible to return to employment with the City. Employees who separate from the City reasons other than layoff, are applying for a different position, and/or the Preferred List for their position classification has timed out may apply for positions through the regular civil service entrance list or hiring procedures for the respective position.

This does not refer to seasonal or part-time employees who may be reinstated on an annual basis upon recommendation of the affected Department Head and approval of the City Administrator.

Recall from Layoff:

Employees who have been laid off will be placed on a "Preferred List" for their respective position classification for up to three years from the date of the layoff (in accordance with Section 5.2 of the Ottumwa Civil Service Commission – Local Rules & Regulations).

Whenever the Employer is looking to fill a vacancy, the affected Supervisor shall first identify if any names appear on a Preferred List for the particular position classification. If any names appear on the list, appointments shall be made from that list in the order of greater seniority until the list has been exhausted or time expires.

Reinstatement:

In accordance with the City Personnel Policy employees returning to City service through Preferred Lists, Entrance Lists, or other open hiring practices for the City will be assigned their most recent “Date of Hire” upon their return. The Date of Hire is typically referenced for purposes relevant to seniority.

Where “Years of Service” is utilized (e.g. calculating vacation benefits) the returning employee shall receive credit for their prior service in the same job classification and / or department in regular, full time position(s). This applies to employees who are returning to active employment within three (3) years of their previous separation date.

In these instances the Employer will establish an “Adjusted Date of Hire.” The Adjusted Date of Hire will be calculated by identifying the total number of days the Employee had previously served in a regular, full-time position for the City and roll back this total from the current Date of Hire.

ARTICLE 5. CIVIL SERVICE

The duties and powers of the Civil Service Commission are set forth in Chapter 400 of the Code of Iowa, as if may be amended from time to time. The Mayor appoints Civil Service Commission members. The Commission will issue its own policies and procedures. The City Clerk serves as the Secretary to the Civil Service Commission as provided by Chapter 400 of the Code of Iowa.

The City Clerk keeps current lists of those employees covered by Civil Service as well as seniority lists in each employment category. Lists are posted at City Hall.

Seniority with the City is the length of an employee’s continuous service with the City from the employee’s most recent date of hire for calculating benefits. Classification seniority is the length of an employee’s continuous service within a civil service classification.

An employee shall lose his seniority rights and the employment relationship shall be broken and terminated as follows:

1. Quits or retires;
2. Discharge, and discharge is not reversed through grievance procedure;
3. Fails to report to work at the end of a leave of absence;

4. Does not report for work for a period of three consecutive days, and does not notify the Employer; or
5. Has been laid off. When the work force is reduced, the employee loses his/her seniority rights. Employees facing work force reduction will be given at least two weeks of notice of the layoff. Employees facing a reduction through layoff or job abolishment may apply for any open positions in the City or may test for another position in accordance with civil service rules.

Job posting for open positions within the Public Works and Muni Bargaining Agreement positions will be dated and transfers of employees will be at the convenience of the City but preferably no later than forty (40) days after the date of the job posting. Notice of all vacancies or newly created positions will be posted by the City on the employee bulletin board and in UKG. Employees, with civil service seniority in that classification, shall be given ten (10) calendar days' time in which to make application to fill the position. The employee with the best qualifications, as determined by the Department Head, will be assigned to fill the position. The employee has fourteen (14) days to disqualify him/herself and return to their former position if it is available. Employees may only exercise the self-disqualification once every two (2) years. The City has up to thirty (30) days to disqualify employees and return that employee to his/her former position if it is available.

ARTICLE 6. RESIDENCY REQUIREMENTS

Unless specified in a collective bargaining agreement, there is no requirement that an employee live in a specific community or county. However, each employee is expected to report to work on time and at all times when his/her office/work station is in operation. While the employee's domicile is not a condition of employment, neither is it a justification for not reporting to work in a timely manner.

ARTICLE 7. NEPOTISM

It is the policy of the City of Ottumwa to hire and promote employees on the basis of their qualifications, merits and for the good of the public service. It is the policy of the City of Ottumwa to prohibit nepotism in hiring, promotion, demotion, termination or other personnel actions pertaining to city employees, and to avoid the appearance of nepotism in personnel actions.

For purposes of this policy, nepotism is defined to mean that the City will not hire members of the same family, as hereinafter defined, to work in the same department or division within a department. Family members are defined for the purpose of this section of this policy as follows: parent, stepparent, child, stepchild, stepsibling, daughter, sibling, spouse, grandparent, grandchild, parent-in-law, son-in-law, daughter-in-law, half-sibling, cohabitating couples.

The following family members are not allowed to have direct or indirect supervisory or administrative authority over any family member, as hereinafter defined. Family members are defined as those in the previous paragraph in addition to any aunt, uncle, niece, nephew, brother-in-law, sister-in-law, grand-parent-in-law, first cousin.

Family members working in the same department as of the date this policy is adopted will be exempt from this policy. Employees who become family members after the adoption of this policy will also be exempt, although future transfers, promotions and new shift assignments shall be governed by this policy. Employees who marry each other or cohabit together after they are both employed by the City, shall notify the City and, if one of them is in a supervisory position over the other, the employee in the supervisory capacity shall be discharged unless the other employee, within thirty (30) days of such marriage, resigns or transfers to a vacancy in another department for which he or she can qualify.

Exceptions – The Ottumwa Beach may have family members working at the Beach. However, employees may not be supervised by family members.

ARTICLE 8. WAGES/JOB CLASSIFICATIONS

Non-bargaining unit employees, excluding Department Heads, will be paid in accordance with the City's non-union pay plan adopted by the City Council on June 20, 1989 and effective July 1, 1989.

Employees will be paid on a bi-weekly basis. If the regular payday occurs on a holiday, the preceding workday is the payday. Direct deposit must be set up for each employee, except for those employees whose hire date precedes July 1, 2005. Those employees may continue to receive an actual check. A holiday may require the direct deposit to occur the next working day after the holiday.

Copies of paychecks are available in UKG the morning of payday. Employees receiving a paper check will be available for the Department Heads or their designee to pick up in the Finance Department after 11:30 a.m. on payday.

Employees on each payday will receive in addition to their check or direct deposit stub, a statement showing gross pay, deductions, and net pay. State and Federal taxes, as well as pension withholding required by Federal and Iowa law, will be deducted automatically. No other deductions will be made unless required or allowed by law, contract or employee obligation, such as garnishments. Employees may elect to have additional City approved deductions taken from their pay only if they authorize the deductions in writing.

Employees who discover a mistake in their paycheck, should notify the Finance Department immediately. Employees are responsible for promptly reviewing each paystub to determine if there are any errors. In the case of mistake on the part of the Finance Department, the error will be remedied promptly. If the mistake was on the part of the employee, it will be corrected on the next paycheck. However, the employee is solely responsible for any monetary loss, and the City cannot be responsible for the loss or theft of money from an employee's account.

Employees may discuss any questions or concerns regarding their rate of pay and/or the City's pay plan with their Supervisor, Department Head, Finance or Human Resource Department.

Employee Definitions

Full-time Employee – An employee is considered a full-time employee if they are scheduled to work 40 or more hours a week on a regular basis.

Regular Part-time Employee – An employee is considered a part-time employee if they are scheduled to work less than 40 hours a week on a regular basis.

Variable Part-Time Employee – An employee is considered a variable part-time employee when they are scheduled less than 30 hours per week and their hours will vary week to week.

Seasonal Employee - Seasonal employees are defined as those who work on a seasonal basis (typically no more than 6 months) at one or more of the various departments within the City. These employees will work varied schedules pursuant to the department's operating hours. Seasonal employees will receive no benefits other than those afforded to them by State or Federal regulations.

Contracted Employee – A contracted employee is one that is hired through our current employment agency. The contracted employee will be paid directly by the employment agency and all benefits will be offered through the employment agency, not through the City of Ottumwa.

Exempt Employee – An employee is considered exempt meaning they are exempt from the overtime rules of the Fair Labor Standards Act (FLSA). This is because they are classified as an executive, professional, administrative or certain computer professional employee and meets the specific criteria for the exemption. With some limited exceptions, exempt employees must be paid on a salary basis.

Non-exempt Employee - An individual who is not exempt from the overtime provisions of the FLSA and is therefore entitled to overtime pay for all hours worked beyond 40 in a workweek (unless stipulated otherwise in a collective bargaining agreement). Nonexempt employees may be paid on a salary, hourly or other basis.

Overtime/Compensatory Time

Consistent with efficient operations and service, it is City policy that overtime be minimized. Overtime must be authorized by the Department Head prior to its utilization.

Overtime is time authorized by the Department Head or designee in advance, assigned, and worked by employees in non-exempt positions in excess of the regularly scheduled work shift or workweek. Overtime is paid at the rate of one and one-half times the employee's regular hourly rate of pay for hours over 40 per week, or as defined by the Fair Labor Standards Act.

- Overtime rates for police and fire departments are different as bargained and as pursuant to the Fair Labor Standards Act.
- Due to the nature of their work, field supervisors will have overtime figured as per their department's collective bargaining agreement. This applies to classified events (snow, flooding, etc.), call-backs, and mandatory overtime
 - Field Supervisors are defined as those non-exempt supervisors working in Streets, Sewer, Traffic, Central Garage, Engineering Supervisor, Water Pollution Control and the Recycling Center.

Unless negotiated as part of a collective bargaining agreement, paid holidays, incentive time, vacation, sick leave or comp. time are not considered as time worked under Fair Labor Standards.

Compensatory time off in lieu of overtime is calculated at the rate of one and one-half times the employee's regular hourly rate of pay. Compensatory time may be accumulated up to a maximum of one hundred (100) hours; not more than forty (40) hours may be carried past November 1 each year. A Department Head may reduce overtime for non-union covered non-exempt positions by allowing flex time during the week overtime would be accumulated. For instance, if an employee works an hour of overtime on Tuesday, the Department Head may allow the employee to leave an hour early on Friday of the same week that overtime occurred.

Payment for overtime, flex time or compensatory time off is determined by the Department Head.

Once an employee moves from a non-exempt position to an exempt position, any comp time that they have accumulated will be paid out on their next scheduled pay at their last hourly rate.

An employee on paid leave shall be considered on paid leave until their next scheduled work day and will not be called in for overtime unless in the case of an emergency.

ARTICLE 9. HOURS OF WORK

It is the policy of the City of Ottumwa to establish the time and duration of working hours as required by workload and service needs, the efficient management of human resources, and any applicable law. The City expects its employees to be reliable and to be punctual in reporting for scheduled work. Absenteeism and tardiness place a burden on other employees and on the City. In the rare instances when employees cannot avoid being late to work or are unable to work as scheduled, they should notify their supervisor as soon as possible in advance of the anticipated tardiness or absence. Poor attendance and excessive tardiness are disruptive. Either may lead to disciplinary action, up to and including termination of employment.

The normal workweek is Sunday through Saturday, and consisting of eighty hours within a pay period. Fire, Police and other personnel may have varying schedules. Department Heads or designee may schedule overtime or extra shifts when it is necessary. Employees are not permitted to work overtime without the prior approval of their Supervisor or Department Head.

All non-exempt employees are required to complete an individual time record showing the daily hours worked. All non-exempt employees are required to punch into the UKG System when reporting to duty and punch out of the UKG System when ending their shift. Employees are NOT allowed to work "off the clock." Employees who fail to properly punch in and out for work and meal periods will be subject to disciplinary action, up to and including termination of employment.

Each Department Head or designee will determine the scheduled hours for employees. The Department Head or designee will inform employees of their daily work schedule, including meal periods and breaks, and of any changes that are considered necessary or desirable by the City. When able to do so, breaks should be taken at the work location.

Breaks are defined as short periods of rest lasting less than 20 minutes and are considered compensable time. Meal periods are 30 minutes or longer and aren't compensable time unless the employee is required to continue working while eating. Employees are to be completely relieved from duty during their meal break. If a nonexempt employee is required to perform any work duties while on his or her meal break period, the employee must be compensated for the time spent performing work duties. The time spent working during the meal break will be counted toward the total hours worked.

Personnel employed in executive, administrative, or professional capacities generally are exempt from the provisions of the Fair Labor Standards Act. These employees are not required to fill out hourly time records but must account for daily attendance and time spent on particular categories of activities to be accountable for public projects and for payroll purposes.

ARTICLE 10 - BENEFITS

The City's Benefit package is set out as follows. It should be noted that this package can vary between departments and employees covered by independent boards and pursuant to applicable collective bargaining agreements. The following is a general overview of these benefits. Employees with specific questions regarding the benefit package within their department should address those questions to their Department Head, Supervisor or Human Resources.

Unless otherwise stated, Variable Part-time, Seasonal and Contracted employees are not eligible for benefits.

HOLIDAYS:

The following will be recognized as paid holidays for City employees unless otherwise stipulated except those employees covered by independent boards or collective bargaining agreements.

| | |
|------------------------|----------------------------|
| New Year's Day | Veteran's Day |
| Memorial Day | Thanksgiving Day |
| Independence Day | Day after Thanksgiving Day |
| Labor Day | Christmas Day |
| Martin Luther King Day | President's Day |

One (1) day (eight (8) hours) the last working day before or after Christmas, as designated by the Mayor.

Full-time employees will be paid at eight (8) hours per holiday. Regular part-time employees will be paid a pro-rated amount based upon their budgeted hours.

When a holiday falls on Saturday, the holiday shall be observed on the preceding Friday. When a holiday falls on a Sunday, the holiday shall be observed on the following Monday.

Any employee eligible for overtime under Article 8, who works by request of the employer on his/her holiday shall be paid the holiday pay plus overtime rate of one and one-half (1 ½) times his/her regular rate for hours worked. Police and Fire personnel who are granted holidays to be taken in conjunction with vacation and other leave will not be paid overtime for working the scheduled holidays.

An employee shall forfeit his/her right to payment for any such holiday if he or she has an unexcused absence on the last regular working day preceding such holiday or on the next regular working day following such holiday.

For religious or other holidays not listed above, an employee must use vacation or personal days.

For Public Safety employees (Fire and Police), holidays will be granted as floating holidays.

- Police – all Sergeants, Lieutenants and the Police Chief will be given 88 hours of holiday pay each year on November 1st. Holiday pay not used by October 31st shall be forfeited.

VACATION:

It is the policy of the City of Ottumwa to grant its employees paid vacation time to accrue based on years of service. Use of accrued vacation time is to be granted, with due consideration to departmental staffing needs.

All full-time employees and regular part-time employees will accrue vacation leave benefits. Part-time employees will accrue vacation leave on a pro-rated basis based upon the number of hours budgeted each fiscal year.

Every employee shall be eligible for a vacation with pay after successfully completing the probationary period. Employees shall start to earn vacation leave at their first date of employment and shall accrue vacation time bi-weekly. Employees increase will take effect on the first day of the pay period closest to the date of the actual increase. Employees receiving an increase in vacation will accumulate as set out below.

Vacation allowance shall be earned annually and shall be based on the employee's anniversary date as follows, unless otherwise stipulated by an employment agreement with that employee:

| Years of Service | Vacation Period | Bi-Weekly Vacation Accrual |
|---------------------|-------------------|-------------------------------|
| 0 through 5 years | 80 hrs – 2 weeks | 3.08 hours |
| 6 through 12 years | 120 hrs – 3 weeks | 4.62 hours |
| 13 through 20 years | 160 hrs – 4 weeks | 6.15 hours |
| Over 20 Years | 200 hrs – 5 weeks | 7.69 hours |

Upon retirement, death, or any other type of separation, vacation credit shall be given based on the employee's accumulation.

Vacation requests shall be made in the following manner:

1. Vacation requests must be made through UKG. All requests will be routed to the direct supervisor for approval. All vacation requests must be approved by the Department Head

or designee or City Administrator before vacation may be taken. Scheduling of vacation time shall be the responsibility of Department Head or designee, subject to staffing needs.

2. Vacation periods may be changed after they are approved only with the approval of the Department Head or designee or City Administrator.

Accrued vacation will be limited to an amount equal to 1 ½ times the employee's annual accrual rate at any point in time. Once that limit is met, the employee will begin to lose vacation accrual over the limit. It is the employee's responsibility to watch their accruals set out in their paystub to determine when the employee could lose vacation time if not used.

An employee called in to work on a vacation day will receive pay of time and one half plus the vacation pay (double time and a half) or be paid time and one half and receive another day off later.

SICK:

It is the policy of the City of Ottumwa to grant its employees paid sick time to be used during times of incapacitation for work. This includes time needed to address the medical needs of an immediate family member. An illness or injury to spouse or minor child which requires the employee's immediate attention will cause time to be used from sick leave to make arrangements for medical and other needs up to a maximum of eighty (80) hours per fiscal year.

Sick pay is not, however, interchangeable with paid vacation. The use of sick pay by any employee for non-medically related absences from work is considered to be sick pay abuse and subjects the employee to disciplinary action.

All full-time employees and regular part-time employees will accrue sick pay benefits. Part time employees will accrue sick pay on a pro-rated basis based upon the number of hours budgeted each fiscal year. Seasonal and/or temporary employees will not accrue sick pay benefits.

Any eligible employee contracting or incurring any non-service connected sickness or disability which renders such employee unable to perform the duties of his/her employment shall receive sick pay, subject to the provisions of this policy. Sick leave does not include elective cosmetic procedures. If an employee is exposed to a contagious disease and a doctor certifies the employee would endanger the health of others by attendance at duty, sick pay may be used.

Employee doctor and dentist appointments may also be charged as sick pay when they cannot be scheduled outside the employee's regular work hours. Sick pay will only be allowed for the doctor's appointment and reasonable travel time to and from the doctor's office.

Eligible employees shall earn and accrue sick pay at the rate of 7.39 maximum hours per pay period for continuous service starting on the date of entry to the service unless provided for otherwise pursuant to a collective bargaining agreement.

On the first payday after November 30th of each year, each current employee shall be paid for 25% of accrued sick pay in excess of 1920 hours, up to a maximum of forty-eight (48) hours and the employee's sick pay accrual will be reduced to 1920 hours. The date used will be the pay period ending closest to November 1 of each year for determining payment. An individual must be employed at that time to be eligible for the payout.

Unless otherwise provided in a collective bargaining agreement, beginning November 1 of each year, each employee receives 8 hours casual time which must be used by the following October 31st. Casual time is deducted from employee's accumulated sick pay.

An employee, on leave because of an occupational disability related to his/her employment, may take such sick pay allowance to which he/she is entitled and the prorated amount will be added to the amount of disability/worker's compensation which will result in an equivalent payment to the employee of a full salary for any particular period.

Sick pay may be used for absence caused by sickness, injury, disability, or pregnancy. Sick pay will not be used for employees on vacation or holidays. Employees shall be eligible for pay for any holiday falling within a pay period for which they received compensation.

Donated time - Employees who have exhausted their sick pay may utilize vacation leave donated by another employee. Donations are voluntary and shall be turned in confidentially to the Human Resources department for the benefit of the employee on sick pay.

The Department Head or City Administrator may require that the use of sick pay be supported by a doctor's statement if the employee (or immediate family member) is off three (3) or more consecutive workdays OR takes more than three (3) workdays off in any 90 calendar day period. An employee returning to work following serious illness or incapacitation will be required to present a written release from his/her physician at the employee's expense. *Please see our Leave Policy for more information.*

Employees shall at all times submit to examination by such medical examiner as may be designated by the city, when required by the appropriate department head or City Administrator. In cases of extended use of sick pay, the employee may be required to appear for a physical examination to determine whether FMLA or leave of absence is necessary.

Employees shall report prior to the start of their shift to their immediate supervisor when they are unable to work because of illness or injury. Each department will determine the amount of time needed to report off on sick pay. Department heads shall report to their departments and City Administrator if they are unable to work. Employees reporting shall inform their supervisors of the anticipated duration of the recuperation period. Text messages or phone calls to co-workers other than their immediate supervisor, are not sufficient notice.

An employee using sick pay in excess of 90 consecutive days will not continue to accrue paid sick time. Sick pay is not an accrued leave benefit and will not be paid out upon the employee's separation from employment with the City.

INCENTIVE:

Unless a collective bargaining agreement provides otherwise, personal leave in the amount of one hour shall be awarded for each pay period in which a full-time employee is not absent from work due to the use of sick leave. No exceptions shall be permitted to excuse an absence, except legal holidays, vacation, and personal days or employees on family medical leave. Personal leave may be taken at any time, but a minimum of twenty-four (24) hours' notice shall be given to the employee's supervisor subject to appropriate staff coverage. A maximum of eight (8) hours of Personal Leave may be carried over each year. The reset period shall be the pay period ending closest to November 1, each year.

PARENTAL LEAVE:

An individual on parental leave may take up to 12 workweeks off under the Family Medical Leave Act (FMLA). If an employee has accrued benefits, they will use this paid time off concurrently with their FMLA leave.

NOTE: At this time, parental leave does not count as dependent sick time, so if after using sick time for parental leave, the baby or other dependent defined as spouse or child, becomes ill, the employee may use 80 hours dependent sick time (if available from accrued sick time) to use during that fiscal year.

Please review our Leave policy for more information.

FUNERAL LEAVE:

Employees may be granted bereavement leave for death in the immediate family, which shall not be deducted from an employee's accumulated sick leave as follows:

- (1) Up to five (5) days for the death of a spouse, child or stepchild.
- (2) Up to three (3) days for the death of a parent, stepparent, sibling, grandchild or employee's own grandparents.

- (3) Up to one (1) day for the death of a father/mother-in-law, brother/sister-in-law, son/daughter-in-law or spouse's grandparents.

Regular part-time employees will be granted funeral leave on a pro-rated basis.

LONGEVITY PAY:

The City will pay full-time and part-time regular employees a longevity rate based on \$25.00 per month for each five years of continuous service. Library employees will be paid a per hour rate set by their collective bargaining agreement. As per the Fair Labor Standards Act, this will be paid as an hourly rate and applied to the base compensation rate to determine an employee's regular rate of pay to calculate for overtime, holiday, incentive, funeral, military, sick (casual and dependent), comp time payment and vacation pay.

| Years of Service | Monthly Amount | Yearly Amount | 2080 Hours | 2184 Hours | 2912 Hours | Library |
|------------------|----------------|---------------|------------|------------|------------|----------|
| | | | Per hour | Per hour | Per hour | Per hour |
| 5 | \$ 25.00 | \$ 300.00 | \$ 0.14 | \$ 0.14 | \$ 0.10 | \$ 0.15 |
| 10 | \$ 50.00 | \$ 600.00 | \$ 0.29 | \$ 0.27 | \$ 0.21 | \$ 0.30 |
| 15 | \$ 75.00 | \$ 900.00 | \$ 0.43 | \$ 0.41 | \$ 0.31 | \$ 0.45 |
| 20 | \$ 100.00 | \$ 1,200.00 | \$ 0.58 | \$ 0.55 | \$ 0.41 | \$ 0.60 |
| 25 | \$ 125.00 | \$ 1,500.00 | \$ 0.72 | \$ 0.69 | \$ 0.52 | \$ 0.75 |
| 30 | \$ 150.00 | \$ 1,800.00 | \$ 0.87 | \$ 0.82 | \$ 0.62 | \$ 0.90 |
| 35 | \$ 175.00 | \$ 2,100.00 | \$ 1.01 | \$ 0.96 | \$ 0.72 | \$ 1.05 |
| 40 | \$ 200.00 | \$ 2,400.00 | \$ 1.15 | \$ 1.10 | \$ 0.82 | \$ 1.20 |

**for reference only – differences may be minimal due to rounding*

FLEX SPENDING PLAN & DEPENDENT CARE ASSISTANCE PROGRAM:

The City currently has a Flex Spending Plan and Dependent Care Assistance Program being administered by Advantage Administrators. These plans allows an employee to set aside dollars each year as a deduction to pay for qualified health and dependent care expenses. These dollars are deducted from the employee's wages before any income or social security taxes are paid. By using this tax savings plan, the employee will not only notice an increase in take home pay, but the employee will have access to a reimbursement account throughout the year to pay qualified expenses. This is on a calendar year basis.

Open enrollment is from November 1 – November 30 of each year. All changes will take effect January 1. A failure to sign up during this open enrollment period will result in the inability to utilize this plan for that year. All employees must sign up each year they wish to participate in the plan. The IRS sets the maximum amount of money that can be placed in this plan annually as

well as how much can be carried over annually. Any amount left in the plan over that limit will be forfeited.

See Human Resources for further information regarding this Plan.

RETIREMENT PLANS:

All regular full time and regular part time employees are covered under one of the following City retirement plans:

1) Sworn Police Officers & Fire Fighters are covered by Chapters 400 & 411 Code of Iowa. Contributions by employee and employer are determined by annual actuarial studies.

2) All other covered employees participate in the Iowa Public Employees Retirement System and Social Security. Contributions by employees and employers are determined by Iowa Public Employees Retirement System. The State of Iowa sets the contribution rates for both the employee and the City of Ottumwa. This plan is subject to all State and Federal retirement regulations.

The City of Ottumwa also offers three (3) different 457(b) plan accounts for additional retirement savings. A 457 (b) plan is pre-tax contribution by the employee. The City of Ottumwa has partnered with Nationwide, Empower (Mass Mutual) and MissionSquare.

See Human Resources for further information.

HEALTH AND LIFE INSURANCE:

The City offers Single to Family coverage to all of its full-time employees. The City has a self-funded plan that is currently being administered by Wellmark Blue Cross and Blue Shield. Currently, the City pays 90% of the monthly premium for a Family Hospital, Medical, Surgical Group Insurance Plan, including major medical coverage and dental coverage, dental coverage to be on the employee only, and 90% of the monthly premium for a single person Hospital, Medical, Surgical Group Insurance Plan, including major medical coverage and dental coverage. In addition, the City pays 90% of the monthly premium for the same type of plan for an employee/spouse or an employee/child(ren). At this time, there is a \$300 deductible for single plans and a \$600 deductible for family plans. The out of pocket is \$1,000 for single plans and \$2,000 for family plans.

Health insurance will be extended to part-time employees in compliance with the Affordable Care Act (ACA). Employees who are budgeted to work more than 30 hours per week upon initial hire will be offered immediate participation in the City's health insurance plans. The

City has established the following initial measurement period to determine eligibility for part-time associates budgeted under 30 hours per week:

- Measurement period – 12 months from 05/01 – 04/30
- Administration period – 2 months from 05/01 – 06/30. The administrative period will align with open enrollment in May of each year to allow employees that qualify to enroll in coverage to start coverage July 1st.
- Stability – 12 months from 07/01 – 06/30 which aligns with our health insurance plan year

The City currently provides a three-tier drug card program for employees and their dependents. The three-tier drug card program consists of a \$10.00/\$25.00/\$40.00 co-pay effective January 1, 2008. The employee currently pays 10% of the cost for these plans. The plan that is in place meets all State and Federal regulations as well as under the Affordable Care Act, including coverage for adult children to age 26. This plan will be subject to change based upon Federal and State regulations.

Any employee who is eligible for insurance coverage under this policy and seeks to include any dependents under their plan, including a spouse, partner, and/or children, will be required to provide proof of the eligible dependent relationship. Documentation of the dependent relationship must be provided to Human Resources before the requested coverage will go into effect. Examples of documents that may be used to verify the dependent relationship can include a marriage certificate, common law affidavit with the current year 1040 tax return, or birth certificate (for child dependents). A full list of accepted documents can be obtained from Human Resources. Questions regarding dependent verification should be directed to Human Resources.

The City of Ottumwa offers Life Insurance for all full-time regular, active employees working a minimum of 40 hours each week. Employees will become eligible for Life Insurance on their start date. Employees may purchase coverage for qualified dependents as per the current pricing schedule. Dependents are defined as per the plan document and schedule of insurance. Please contact Human Resources for a copy of the current rates.

Please review the Insurance Policy and plan documents from our provider for further information.

ARTICLE 11. BENEFITS CONTINUATION - COBRA

The Federal Consolidated Omnibus Budget Reconciliation Act (COBRA) gives employees and their qualified beneficiaries the opportunity to continue health insurance coverage under the City's health plan when a "qualifying event" would normally result in the loss of eligibility. Some common qualifying events are resignation, termination of employment, or death of an employee;

a reduction in an employee's hours or a leave of absence; an employee's divorce or legal separation; and a dependent child no longer meeting eligibility requirements.

Under COBRA, the employee or beneficiary pays the full cost of coverage plus an administration fee. The City provides each eligible employee with a written notice describing rights granted under COBRA when the employee becomes eligible for coverage under the City's rights and obligations. Contact the Human Resources Department for more information about COBRA.

ARTICLE 12. EMPLOYEE LEAVE POLICY

Eligible employees may request leave pursuant to the terms and conditions of the federal Family and Medical Leave Act (FMLA). If an employee does not qualify for leave under FMLA, eligible employees may qualify for a leave of absence for a period not to exceed one (1) year, unless otherwise stipulated by a collective bargaining agreement.

If an employee has accrued time off (sick, vacation, comp), they will use this time concurrently with FMLA or a paid leave of absence. If an employee has accrued time off and only qualifies for a personal leave of absence, they must exhaust the accrued time before taking an unpaid leave of absence.

The Department Head may authorize leave with pay, which will not be charged to vacation or sick leave, for the following reasons:

- For appearance in court, either as a member of the jury, or when required to appear as a witness in a criminal case. If the employee is required to appear as a witness in a civil case not involving the City or the employee is a Defendant in a criminal case, the employee will need to take accrued leave. When an employee appears in court pursuant to jury duty or as a result of a subpoena during regular working hours and receives full pay from the City, any jury or witness fees that the employee might receive except for mileage from the Court, will be turned over to the City Clerk's office.
- For attendance at an official meeting where the good of the City is involved, but within the budget allowance for this purpose. All leave with pay except those related to sickness or injury must be applied for in advance.

Please refer to the Leave of Absence Policy for more information.

ARTICLE 13. MILITARY LEAVE

In accordance with Iowa Code, Chapter 29A.28, "Leave of Absence of Civil Employees," all municipal employees when ordered by proper authority to active military service shall be

entitled to a leave of absence for the period of such active service without loss of pay during the first thirty days of such leave of absence.

Active service for a period of less than thirty days: When such active service is for periods of less than 30 days, a leave of absence shall be required and the employee will be paid for those days that the employee would have normally worked. Payments will not exceed thirty (30) total calendar days in any calendar year.

Active service for a period of more than thirty days: When such active service is for a continuous period greater than thirty days, this leave of absence will be without pay except for the first thirty days during which time the employee will suffer no loss of normal pay. This means the employee will be paid only for those days that normally would have been work days during this first thirty day period. But, again, in any case, payments for accumulated periods of less than thirty (30) days and more than thirty (30) days will not exceed payments for greater than a total combined period of thirty (30) days.

Beginning Date: The period of thirty days for such payment begins with the date such employees are ordered to report to their home station in preparation for mobilization.

Proper Authority: The proper authority for any such activation is the Office of the Adjutant General, Headquarters, Iowa National Guard, for National Guard soldiers, or the Office of the Adjutant General, Headquarters, US Forces Command for soldiers of the Army Reserve. The authorization for the City to make such payment will be a valid copy of written orders with appropriate order numbers from the authorizing headquarters provided to the City Administrator or designee.

ARTICLE 14. HARASSMENT POLICY

It is the policy of the City of Ottumwa, Iowa, to strictly prohibit discrimination and harassment and to maintain a professional and quality working environment for all employees or future employees. It is the City's policy that all employees have a right to work in an environment free of discrimination and harassment based on sex, age, race, national origin, religion, disability, genetic information, sexual orientation, marital status, or any other basis protected by federal, state, or local law. The City prohibits harassment of its employees in any form—by supervisors, co-workers, customers, or suppliers.

The City of Ottumwa has a zero tolerance policy for any form of sexual harassment in the workplace, and will treat all incidents seriously and promptly investigate all allegations of sexual harassment. Any person found to have sexually harassed another will face disciplinary action, up to and including dismissal from employment. All complaints of sexual harassment will be taken seriously and treated with respect and in confidence. There shall be no retaliation for the

submission of a complaint unless the complaint is proven to be false. Harassment may also be based on another protected class and can be in violation of the City's Equal Employment Opportunity Policy set out in Article 3. All procedures set out for other illegal harassment will be followed based upon this policy.

Sexual Harassment is a violation of Section 703 of Title VII Civil Rights Act of 1964. The City defines sexual harassment as:

1. Unwanted sexual advances
2. Requests for sexual favors
3. Other verbal or physical conduct of a sexual nature

These constitute sexual harassment when:

- Submission to such conduct is a term or condition of employment
- Submission to or rejection of such conduct is used as the basis for employment decisions affecting the individual
- Such conduct unreasonably interferes with the employee's work or creates an intimidating, hostile or offensive working environment

Sexual Harassment may be physical in nature, verbal and non-verbal conduct. Inappropriate physical conduct includes unwelcome physical contact, touching and violence. Inappropriate verbal conduct includes comments regarding a person's appearance, age, private life, sexual comments, jokes and stories, sexual advances, repeated and unwanted social invitations, insults, condescending or paternalistic remarks and sending sexually explicit messages through text, phone or e-mail. Inappropriate non-verbal conduct includes displaying sexually explicit or suggestive materials, gestures, whistling and leering.

Sexual harassment is a manifestation of power relationships and often occurs within unequal relationships in the workplace, for example between a supervisor and employee. It can also include clients, customers, contractors or visitors. It is possible that a co-worker may take offense even though that person is not the direct target of the sexual harassment.

COMPLAINTS PROCEDURES:

Anyone who is the subject of sexual harassment should, if possible, inform the alleged harasser that the conduct is unwanted and unwelcome. However, if the victim cannot directly approach an alleged harasser, he/she can file a complaint with the City Administrator or designee.

When a complaint is received, the City Administrator or designee will:

- immediately record the dates, times and facts of the incident(s)
- ascertain the views of the victim as to what outcome he/she wants
- ensure the victim understands the city's procedures for dealing with the complaint

- discuss and agree to the next steps: either informal or formal complaint, on the understanding that choosing to resolve the matter informally does not preclude the victim from pursuing a formal complaint if he/she is not satisfied with the outcome
- keep a confidential record of all discussions
- respect the choice of the victim
- ensure that the victim knows that he/she can lodge a complaint with the Iowa Civil Rights Commission at any time

Throughout the complaint procedure, a victim is entitled to be helped by a counsellor through the City's EAP program.

Any City employee who has been found to have sexually harassed another person under the terms of this policy is subject to the City's Disciplinary Process, including termination. The nature of the sanctions will depend on the gravity and extent of the harassment. Suitable deterrent sanctions will be applied to ensure that incidents of sexual harassment are not treated as trivial.

ARTICLE 15. INTERNAL INVESTIGATIONS

It is the policy of the City of Ottumwa to provide a method by which employee conduct may be investigated by the city to: (1) protect the public from employee misconduct, (2) protect the city's image and avoid claims against the city, (3) protect the employee against false allegations of misconduct, (4) remove unfit personnel, and (5) correct procedural problems. Investigations involving Police and Fire personnel shall be handled pursuant to Chapter 80F of the Code of Iowa.

1. The City Administrator or department head may cause an internal investigation to be initiated. Unless the City Administrator or designee is the subject of the investigation, he/she will be notified and participate in the investigation. A copy of the report will be forwarded to the City Administrator.
2. The person initiating the internal investigation shall appoint one or more city employees to conduct the investigation.
3. The internal investigation shall be conducted in a manner substantially similar to a Police Department internal investigation. The person or persons conducting the investigation shall consult the attorney designated by the City Administrator before initiating the investigation to ensure that the investigation's procedures comply with appropriate legal standards.
4. The employee under investigation and any other employee with information about the matter shall be required to answer fully and truthfully all questions related to his\her fitness for city employment and the performance of official duties. Refusal or failure to answer such questions fully or truthfully may result in disciplinary action, including termination.

The investigator who is conducting the investigation will provide all necessary warnings to the employee required by law, including but not limited to the Garrity Warning.

5. Upon completion of the internal investigation, those assigned to conduct the investigation shall make full written report to the person initiating the investigation for review and disposition. Copies of the completed investigation report shall be forwarded to Human Resources and the City Administrator.

ARTICLE 16. EMPLOYEE ASSISTANCE PROGRAM (EAP)

It is the policy of the City of Ottumwa to make available for its employees and their dependents confidential counseling and guidance for problems such as alcohol and drug abuse, marital and family problems, mental and emotional illness, and financial, legal and similar areas of concern that may be contributing to unacceptable job performance. The current EAP provider is the Southern Iowa Mental Health Clinic, located at 1527 Albia Road, Ottumwa. The contact telephone number is 641-682-8772. The EAP provider may change periodically. City employees will be promptly notified of any change. An employee may call directly for an EAP appointment, may go through the City Administrator or designee or through the supervisor.

The city may suggest an employee take advantage of the EAP if it is observed that the employee has a deterioration in work performance or attendance or other incidents which indicate a possibility of a personal problem.

- a. The basis of the referral should be a written account of the performance problem that is observed. The account should be as detailed as possible including the dates, times and descriptions of behaviors that have become a part of a pattern of deterioration or particular incidents that warrant supervisory action. This may not be possible in cases such as those involving use of alcohol or drugs on city property which require immediate attention.)
- b. The supervisor should meet with the employee with the problem to discuss the performance problem and communicate clearly the consequences of failure to resolve the problem. In this meeting, the supervisor should not speculate as to the cause of the performance problem nor engage in discussion with the employee concerning any personal problems. (Should a particularly unusual pattern develop, the supervisor may consult with the EAP counselor prior to his\her meeting with the employee).
- c. After the employee has been confronted with the performance problem, the supervisor must review the EAP with the employee, advise him\her of the availability of confidential professional assistance for any work-hampering personal problem and strongly encourage the employee to allow the supervisor to

arrange an appointment with the EAP counselor. While the final decision to use the EAP shall be left up to the employee, the supervisor should emphasize the importance of the EAP.

- d. If the employee agrees to accept assistance, the supervisor should call the EAP counselor and arrange a meeting between the employee and the EAP counselor. The counselor will advise the supervisor of any further action which might be necessary.
- e. The supervisor should make available to the EAP counselor all information that is relevant to the performance problem of the employee prior to the arranged meeting. If necessary, the EAP counselor will request a conference with the supervisor to further discuss the situation.
- f. If the employee chooses not to accept assistance at this time, the supervisor should reinforce the expectation for improved performance and the consequences for failure to improve. The supervisor should also point out that the EAP will be available should the employee change his/her mind in the future. The discussion of the EAP as an option should be clearly documented by the supervisor.
- g. All information pertaining to the employee's referral to the EAP and information provided by the EAP counselor to the supervisor should be accorded the same high standards of confidentiality as applied to other disciplinary procedures and personnel records.
- h. The supervisor will be sensitive to the employee's needs while the employee is involved in the program and participate, as needed, in the continuing recovery plan.
- i. In all cases of formal supervisor requests, particularly those associated with job performance problems on the part of the employee), the EAP will provide follow up information to the supervisor. Only information related to the employee's cooperation with the EAP and ability to perform his/her duties will be released. This release of information may require written permission by the employee, under Federal or State law.

It is expected that city employees will comply with any referrals for diagnosis and cooperate with prescribed counseling or therapy. Employees who refuse evaluation, diagnosis and treatment, if indicated, will be handled in accordance with standard administrative disciplinary policies for unacceptable job performance. The City of Ottumwa EAP is not to be considered a

substitute for disciplinary action and failure to receive treatment and to make satisfactory progress will result in the employee being subject to normal disciplinary procedures.

Time away from work will be treated the same as for any other absence due to illness, injury, or for personal reasons. An employee may use accumulated available sick leave, vacation, personal days and/or compensatory time during the treatment if the employee must be absent. It is the responsibility of the employee to advise his\her department immediately of the need to be absent from work. An unpaid leave must be requested for any portion of leave time not covered by paid leave, pursuant to standard procedures.

While the first 5 visits to the EAP counselor will be paid for by the City, further referrals or trips to the EAP Counselor may result in a cost to the employee which may or may not be covered in full or partially by the City's group health insurance program. The EAP will make every effort to suggest referrals that are covered by insurance and are within the means of the employee to pay.

In cases of drug and alcohol abuse treatment, the treatment must be provided in an approved facility. The employee or dependent must be sure that the facility is approved before entering. Employees or dependents that receive alcohol and/or drug abuse treatment are expected to participate in follow-up therapy. In cases where the employee is referred to a treatment center in lieu of discipline, the employee must remain for the full course of treatment or the employee will be subject to the originally planned discipline. The cost of drug and alcohol abuse treatment will be paid by the employee subject to any coverage by the City's group health insurance program.

An employee who must be absent from work because of counseling or treatment shall be returned to his\her regular position with full benefits and seniority afforded other employees with medical problems if the position has not been filled. The department head will require the returning employee to furnish a return to work release.

ARTICLE 17. ACCIDENT REVIEW

All City employees are responsible for promptly reporting any accidents or near misses that occur while they are on duty. Employees who fail to report any accident will be subject to discipline up to and including termination. A Police report must be filed for all motor vehicle accidents involving on duty City employees and City vehicles. It is the responsibility of the vehicle operator, unless totally incapacitated by the accident, to make sure a Police report is filed. The vehicle operator is also responsible for promptly completing employee accident report forms, which may be obtained from the Department Heads or the Finance Director. All accidents involving City vehicles shall be reported to the Police Department and an officer may be dispatched to do the initial investigation and to complete an accident report. The officer will perform a full investigation to determine if the accident was caused as a result of violating a City

or State traffic law. The Police Department will forward a copy of all reports made to the Finance Director. Depending on the circumstances of the accident, the Sheriff's Department or the Iowa State Patrol may be called to perform an investigation.

Department Heads and supervisors are responsible for reviewing all reports related to accidents or near misses, ensuring the completion of all reports, providing additional information as needed and for promptly forwarding all reports to the Finance Director.

The Risk Manager shall be empowered to review all personal injury accidents and Workers' Compensation claims and all records and information relating to such incidents.

The Risk Manager shall have the right to require written reports from such persons as the Risk Manager shall deem appropriate for the proper determination of the facts surrounding each accident and shall have access to such documentary evidence as may be needed to complete the Risk Manager's investigation. Before making a determination, the Risk Manager will fully investigate each accident or near miss. The procedure for investigation will be established by the Risk Manager.

Following investigation, the "Class" of accident will be determined by the Risk Manager. The decision should be made in a fair, unbiased and objective fashion. Each case must be reviewed on a case-by-case basis. Once a recommendation has been made, both the Employee and the Department will be promptly advised in writing by the Risk Manager. **It will be the Department Head's responsibility to administer disciplinary action after notification from the Risk Manager of the "Class" of accident determination.**

The Employee may appeal the Risk Manager's ruling in writing, submitted to the City Administrator within ten (10) working days of the dated written notice sent to the Employee of the findings/actions. The City Administrator shall review the appeal, may interview the employee, witnesses, and will speak to the Department Head and/or Supervisor. Within thirty (30) days of the receipt of the written notice by the Employee, the City Administrator may affirm, modify, or reverse the ruling based upon the merits presented at the appeal.

All personal Bodily Injury Forms must be properly completed and forwarded to the City Administrator or designee for distribution. This allows the employee, supervisor and Department Head an opportunity to submit factual as well as subjective information to the Risk Manager who will determine whether or not an employee was negligent in actions which contributed to the accident or near miss.

The determination of negligence will be based on all information presented and not exclusively on a violation of the City or State traffic codes. The Risk Manager may have the following information available to them when reviewing an employee's motor vehicle accident.

1. Possession of valid license
2. Driving experience with the City
3. State driving record

Procedures:

1. The following will be classified as vehicle/equipment accidents for the purpose of review by the Risk Manager.
 - a. Property damage to a third party
 - b. Damage to City vehicle or City property
 - c. Bodily injury to a third party as a result of an accident
 - d. Bodily injury to employee
2. Definitions:
 - a. Unavoidable – an accident/incident which resulted in a finding of nonfault.
 - b. Minor, but avoidable – the accident is one that poses minimum danger to life and property, a mistake.
 - c. Avoidable/mitigating circumstances – an accident with extenuating circumstances.
 - d. Avoidable/negligence – the individual responsible for the act or action had a duty and that duty was violated. The act caused the accident. Damages resulted.
 - e. Avoidable/Carelessness – the individual responsible for the act or action carelessly violated a law or one or more specific safety policies and procedures.
 - f. Negligence with intent – act or actions which demonstrate an intentional lack of care or caution of consequences marked by total disregard for caution when that person should have realized it.
3. Accident Causes
 - a. Worker's Compensation accidents can usually be broken down generally into two causes:
 - i. an UNSAFE ACT - usually account for 85% of accidents
 1. Making safety devices inoperable
 2. Failure to use guards provided
 3. Using defective equipment
 4. Servicing equipment in motion
 5. Failure to use proper tools or equipment
 6. Operating machinery at unsafe speed
 7. Failure to use proper tools or equipment
 8. Operating without authority
 9. Lack of skill or knowledge

10. Unsafe loading or placing
 11. Improper lifting, lowering or carrying
 12. Taking unsafe position
 13. Unnecessary haste
 14. Influence of abusive substances
 15. Physical limitation or mental attitude
 16. Unaware of hazard
 17. Unsafe act of another
- ii. an UNSAFE CONDITION – usually account for 15% of accidents
1. Inadequate guards of protection
 2. Defective tools or equipment
 3. Unsafe condition of machine
 4. Congested work area
 5. Poor housekeeping
 6. Unsafe floors, platforms, stairways
 7. Improper material storage
 8. Inadequate warning system
 9. Fire or explosion hazards
 10. Hazardous substances
 11. Inadequate ventilation
 12. Excessive noise
 13. Inadequate illumination
 14. Hazardous atmosphere: gases, dust
 15. Fumes or vapors

All unsafe conditions should be reported immediately to the supervisor.

4. Accidents Involving On-Duty Employees Operating City-Owned Vehicles:

When available and if the severity of damage necessitates it or the accident involves an injury, an outside law enforcement agency may be requested to conduct the investigation. This will require supervisors and officers to use their discretion as to whether an outside agency will be contacted. If the Police Department does investigate the accident, the investigating office will then forward the accident report as well as any other paperwork relating to the investigation to the City Administrator or designee, who will determine whether a traffic citation should be issued and, if so, to whom.

The Police Department is not precluded from taking enforcement action against any driver for those violations that are incidental to the accident, such as drunk driving or driving under suspension. The Police Department may also arrest any driver or occupant for a criminal offense

that may be observed. City employees may also be subject to drug and alcohol testing based upon the City's Substance Abuse Policy set out in Article 35.

ARTICLE 18. WORKER'S COMPENSATION/ RESTRICTED DUTY ASSIGNMENTS

Employees who are injured on the job could be eligible for worker's compensation coverage. The Employee is required to promptly report any injury by calling the "Company Nurse" telephone number on the card provided to each employee upon employment. Additional cards may be obtained from Human Resources. The cards are also posted in each department. This is the First Report of Injury. Failure to report an injury promptly without a reasonable explanation may result in disciplinary action against an employee, the supervisor if he/she fails to report the injury, and potentially could result in a denial of work related injury benefits. The injured employee must as soon as possible call the "Company Nurse," report the injury and symptoms and follow the advice of the medical provider for treatment. The "Company Nurse" will direct the injured employee for treatment. If the injury is severe and the employee is unable to call, the employee should seek immediate treatment and the employee's immediate supervisor will make the report. Employees are required to follow all treatment protocol as directed. Medical bills for treatment are to be forwarded to the Human Resource Department. IMWCA is the City's Worker's Compensation administrator.

It is the policy of the City of Ottumwa to establish a policy relative to restricted duty assignments for City employees who are temporarily disabled due to work related injuries.

The City of Ottumwa has established a policy for employees to Return-to-Work or Light Duty assignments after injury or illness for employees who are unable to return to their regular job classifications. This includes employees who are temporarily unable to perform the full functions of their position.

This policy is not intended to supersede or modify the procedures applicable to employees eligible for reasonable accommodation under the Americans with Disabilities Act (ADA) or leave benefits under the Family and Medical Leave Act (FMLA). Inquiries about the ADA or FMLA should be directed to the human resource department (HR).

For further information, please refer to our current Return-to-Work/Light Duty Policy.

ARTICLE 19. EMPLOYEE PHYSICALS AND MEDICAL SERVICES

This policy is established relative to physical examinations for new employees and for medical services for work related injuries and illnesses. The purpose of the policy is to establish a designated Physician or Clinic to perform physical examinations for all new City employees including Police and Fire and to perform medical services for all work related injuries and illnesses.

Emergency care will be handled by the Emergency Department of Ottumwa Regional Health Center if after the doctor's regularly scheduled office hours or in case of medical emergencies. New employee physicals are required for all regular full and part-time employees, which also includes a drug screen and a hearing baseline test. Lifeguards will be required to undergo a drug screen prior to employment. Those physicals are currently conducted by Occupational Health at the Ottumwa Regional Health Center. Drug testing will also occur at the Ottumwa Regional Health Center. All pre-employment physicals and drug testing are paid for by the City.

Any work related injury shall be reported to the on-call Company Nurse promptly. Please see Article 18 for further information regarding Worker's Compensation claims. Under the Iowa Worker's Compensation law Chapter 85, the City is authorized to choose the medical care provided for employees who are injured on the job.

Any employee who is required to hold a CDL pursuant to his/her position, may be required to undergo drug and/or alcohol testing as a result of any accident while on duty.

ARTICLE 20. FITNESS FOR DUTY

Fitness for Duty:

The City endeavors to provide a safe workplace. This policy applies when an employee is having observable difficulty performing his/her work duties in a manner that is safe for the employee and/or for his or her co-workers, or is posing a safety threat to self or others.

The purposes of this fitness-for-duty policy are:

1. To promote the safety and health of employees and citizens
2. To establish procedures by which the City can evaluate an employee's ability to safely and competently perform her/his duties when a health or safety problem arises; and
3. To comply with applicable law.

Procedures:

1. Employees are responsible for managing their health in such a way that they can safely perform their essential job functions, with or without reasonable accommodation, e.g., employee with the flu should stay home, and employees taking medications that advise against driving should not drive.
2. Employees at work or on-call must remain in a fit condition for the entire period.
3. Supervisors may refer employees for a fitness-for-duty evaluation as provided by these procedures.
4. Before a supervisor refers an employee for a fitness-for-duty evaluation, the Human Resources Manager must approve the evaluation unless the circumstances require immediate action. As an alternative to requiring an employee to submit to a fitness-for-

- duty evaluation, the supervisor may send the employee home with pay on an administrative leave pending a determination whether to require a fitness-for-duty evaluation.
5. Application of this policy is not intended as a substitute for other City policies or procedures related to performance. In addition, application of this policy is not a substitute for discipline. In any situation involving misconduct or violation of City policy, disciplinary action may be taken.
 6. The City will pay the cost of fitness-for-duty evaluations and will pay the employee for time spent in the fitness-for-duty evaluation.
 7. An impartial, independent healthcare evaluator, with appropriate expertise in areas including one or more of the following: medical, psychological, alcohol, or other drug conditions, will conduct a fitness-for-duty evaluation.
 8. The City will make the final determination of an employee's fitness-for-duty status.
 9. An employee referred for a fitness-for-duty evaluation will be relieved of duties pending completion of the evaluation. Generally, the employee will be placed on administrative leave.
 10. When an employee is found to be unfit for some or all duties, his or her employment status will be determined on a case-by-case basis, in accordance with City policy and practice and applicable law. The employee may be placed on a medical leave, intermittent leave, or restricted duty.
 11. An employee's pay status while fitness for duty is being determined will depend on his or her employment status and the facts of the case.
 12. In all cases, the City must receive a "return-to-work/fitness-for-duty form" from the independent evaluator before an employee may return to full or restricted duty.
 13. In most cases, a re-entry conference with the supervisor and the Human Resources manager (if appropriate) will occur prior to the employee's return to work.
 14. Noncompliance with a request for a fitness-for-duty evaluation may be considered insubordination and constitute cause if disciplinary action is warranted. False information or the omission of information in the course of a determination of the employee's fitness for duty may also lead to discipline. Employees are expected to fully cooperate with a determination of their fitness for duty.
 15. Confidentiality/privacy
 - a. Records of fitness-for-duty evaluations will be treated as confidential medical records and be kept separate from existing personnel files; this information will be shared only as permitted by law.
 - b. After an evaluation, information available to the employee's supervisor will be limited to:
 - i. Whether a person is fit to resume some or all of his or her job duties
 - ii. Whether a person is a direct threat to self or others
 - iii. Whether a person needs specific reasonable accommodations

This policy may be modified without notice in order to comply with applicable law.

Fitness-for-Duty Certification

Employee: _____

Department/Location: _____

Status: ___ Full time ___ Part time On leave since: _____

You have my permission to have a healthcare provider contact the healthcare provider indicated on this certification for purposes of clarification related to this serious health condition, if necessary.

Signed: _____ Date: _____

(Information below to be completed by healthcare provider)

Effective as of this date, the above named employee is hereby certified as fit to resume work duties as follows:

- ___ Full-time duties, no restrictions
- ___ Full-time duties, with the following restrictions (conditions and duration):
- ___ Part-time duties, no restrictions
- ___ Part-time duties, with the following restrictions (conditions and duration):

Intermittent duties, with the following restrictions (conditions and duration):

Name of healthcare provider: _____
 Address: _____
 Telephone: _____
 Type of practice/ specialty: _____
 Signed: _____ Date: _____

ARTICLE 21. PERSONNEL FILES/EMPLOYEE ACCESS

It is the policy of the City of Ottumwa that personnel files contain all information relevant to the employment history of each city employee. It is the policy of the City of Ottumwa to permit access by all city employees to their own personnel files and to provide for correction of any

erroneous information maintained in such files. Only information related to job performance or business necessity will be maintained in these files.

1. Official personnel files shall be kept at City Hall in the Human Resource office. As the City transitions to an electronic HRIS (UKG), these files may also be held within the system but maintained by Human Resources. The HRIS meets the requirements as established in sections 107 and 209 of the Employee Retirement Income Security Act of 1974, as amended (ERISA) pertaining to maintenance of records.
 - a. Personnel files include all relevant employee information including the following: application for employment, commendations; certificates of completion of any special training, class or degree program; performance evaluations; notices of employee counseling, reprimands, suspensions and any other disciplinary actions; discrimination complaints and statements of grievances. Copies of any performance evaluations and disciplinary actions shall be forwarded to the City Administrator for review.
 - b. All medical information will be kept in a separate Medical file. This will include leave of absence requests, doctor's notes and results of medical exams required by the City.
 - c. All Confidential information will be kept in a separate confidential file. This will include background checks, employment / payroll verification.
2. City employees will be permitted access to their employment files during normal office hours in the Human Resource office, provided that the employee has requested in writing access to their own file. Employees will be permitted to examine, take notes and make copies of any materials contained in their file. Employees wishing to examine their files must have the permission of their supervisor or department head to leave the job. The Human Resource Manager or the person designated by the City Administrator must be present during this examination and may require 24 hour advance notice or schedule review in advance at such time as mutually agreeable.
 - a. If there are files that are electronic, the employee will be permitted to view those items through the current HRIS.
3. An employee may request correction of any alleged misinformation contained in these files. If this request is denied, the employee will receive an explanation of the reason thereof, and will be permitted to place a concise statement of disagreement in the file.
4. Access to the employee's personnel file will be limited to the employee, the employee's department head, Human Resource Manager or representative, City Administrator, by the lawful custodian of the records, or by another person duly authorized to release information, unless otherwise ordered by a court.
5. Except when authorized by a statement signed by the employee or former employee, no information concerning the employee will be given to an outside source other than: confirmation of employment, confirmation of salary, dates of employment, job title, and

department as well as any information considered public records pursuant to Iowa Code Chapter 22, as it may be amended from time to time. It should be noted that under Iowa Code Section 22.7(11)(a)(5) the fact that an employee resigned in lieu of termination, was discharged, or was demoted as the result of a disciplinary action, and the documented reasons and rationale for the resignation in lieu of termination, the discharge, or the demotion is considered public record. A demotion is interpreted as changing an employee from a position in a given classification to a position in a classification having a lower pay grade.

6. All requests for information pertaining to current or previous employment with the City will be forwarded to the Human Resource Manager.

ARTICLE 22. PERFORMANCE EVALUATIONS

It is the policy of the City of Ottumwa to ensure that city revenues are appropriately spent on wages by periodically evaluating the job performance of each employee. It is the policy of the City that each employee may receive an evaluation annually by his/her supervisor. This procedure will assist in employee performance improvement, assist the employee in setting goals, and determining training if necessary.

1. The job performance of each employee will be evaluated by his/her supervisor at the completion of thirty (30) days of the employee's anniversary date.
2. The evaluations shall be conducted privately between the employee and the supervisor at a time and place designated by the department head.
3. The job performance of each department head will be evaluated by the City Administrator at least once a year and before receiving any merit increases.
4. Each employee shall receive a written copy of the results of the evaluation. The form of the evaluation shall be prescribed by the City Administrator. The employee will be asked to sign the evaluation to indicate that he/she has discussed it with his/her department head. A refusal to sign the evaluation shall be so noted on the form.
5. A portion of the evaluation shall consist of designating areas where improvement is needed. At the time of the next evaluation, the evaluator shall note whether improvement has been achieved in those areas.
6. The evaluation shall become a part of the employee's personnel file.

ARTICLE 23. ACCESS TO CITY ADMINISTRATOR

Employees may have access to the City Administrator to present complaints, disputes or disagreements for which union grievance procedures or Civil Service procedures are not applicable. Before employees meet with the City Administrator they shall first present their complaints, disputes or disagreements in a timely fashion through their departmental chain-of-command and/or Human Resource Manager. In the event that such use of the chain of command

constitutes part of the complaint or dispute, the employee may request a confidential hearing with the City Administrator by confidential written request.

ARTICLE 24. CYBERSECURITY

The use of electronic mail and the Internet is necessary for City employees, elected officials, and others serving in an official capacity with the City to communicate with each other more efficiently and to provide superior customer service, increase productivity, and provide opportunities for professional growth. The City encourages the use of these media and associated services because these communications and access to information are useful in conducting City business. It remains, however, that electronic media and services provided on or through City devices are City property and their purpose is to facilitate City business. The goal of this policy is to encourage the responsible and prudent use of this resource.

With the rapidly changing nature of electronic media, this policy cannot establish rules to cover or anticipate every possible situation. This policy is intended to express the City's philosophy and establish general principles to be applied in the use of electronic media and services on City property or with City-owned devices.

Please refer to our Cybersecurity Handbook which outlines the following seven (7) policies:

- General Email/Internet Security and Use
- Personally Identifiable Information and Protected Personally Identifiable (PII) Information Requirements Applicable to all Federal Awards (PII)
- Cell Phone (revision to policy #56-2015)
- Bring Your Own Device (BYOD)
- Acceptable Use
- Online Social Networking
- SAQ Point-to Point Encryption (P2PE)

ARTICLE 25. DISCIPLINARY PRACTICES/PROCEDURE

Certain rules and regulations governing the conduct of all City employees must be adhered to by all employees in order to ensure safe, efficient and successful operation of city functions. This policy is not intended to abrogate the appointing authority's discretion to discipline and/or terminate an at will employee.

To ensure a safe, efficient and effective working environment, city employees need to adhere to city and departmental rules regarding appropriate conduct on the job. It may sometimes be necessary for a supervisor to take disciplinary action with an employee. The City is committed

to a policy of progressive discipline. Progressive discipline is defined as a series of disciplinary measures, ranging from employee counseling to discharge of an employee, designed to effectively correct problems as they occur and to let an employee know if his/her conduct is inappropriate. However, the City reserves the right to terminate promptly or bypass progressive disciplinary steps in the event of flagrant and/or intentional misconduct.

The following items will be considered to be infractions subject to disciplinary action up to and including discharge from employment. This list is not all inclusive of all acts that may be subject to disciplinary action and are illustrative only, but not limited to, the types of behavior for which disciplinary action may be taken.

- Gifts, Gratuities, Fees, Rewards, Loans – Employees shall not, under any circumstances, solicit or accept any gift, gratuity, loan, reward, or fee when there is any direct connection between it and their Department or employment. Employees must abide by the State’s Gift Law, Iowa Code Chapter 68B, as it may be amended from time to time.
- Controlled Substances – Employees shall not use controlled substances other than those prescribed to them by a physician.
- Drugs – No employee shall be at work while under the influence of drugs or be unfit for work because of their excessive use. This includes the abuse of prescription drugs.
- Alcohol – No employee shall report to work while under the influence of alcohol or drink alcohol while at work.
- False Injury Claims - Employees injured while not at work shall not falsely claim it to be an injury while on the job.
- Embezzlement – theft or misappropriation of funds, equipment or property placed in one’s trust or belonging to the City.
- Employee Arrested or Cited - An employee who has been arrested or cited for any criminal violation shall immediately notify the Human Resource department in writing. Conviction of a crime closely or directly related to the ability of the employee to perform his/her job effectively.
- Policies - Employees shall observe and obey the lawful verbal and written rules, duties, policies, procedures and practices of the City of Ottumwa.
- Professional Conduct - Employees shall conduct themselves toward the public in a civil and professional manner that indicates a service orientation and that will foster public respect and cooperation.
- Performance - Employees shall perform their duties in a manner which shall maintain the highest standards of efficiency in carrying out the functions and objectives of the City. Unsatisfactory performance may be demonstrated by an unwillingness or inability to perform assigned tasks or a failure to conform to work standards established for the position.

- Willful, careless, and/or repeated violation of departmental rules, which have been properly posted, standard operating procedures, or any other rules or regulations promulgated by the City.
- Falsification, alteration, deletion of required information or failure to include material information on any application or City record Punching the time clock or unauthorized completion of a time slip for another employee.
- Abusive, improper treatment during the performance of duty to any member of the public, fellow employee or City official, including harassment on the basis of race, creed, color, sex, national origin, religion, age, sexual orientation, marital status, mental or physical disability, or any behavior or harassment which has the effect of producing a hostile work environment.
- Sleeping On the Job - Employees shall not sleep on the job.
- Judgment or Condition - No employee shall report to work or be on the job when his/her judgment or physical condition has been impaired by alcohol, medication, or other substances.
- Use of Equipment – Employees are accountable for the proper use and care of any property or equipment assigned to them, used by them, or placed in their care. Equipment shall not be used in a manner not specified in procedure, directives, training, or in a fashion other than the intended use. If equipment is broken or malfunctions, the employee shall report it to the appropriate person in prescribed manner.
- Committing Unsafe Acts – Employees shall not commit acts or behave in such a manner that has the potential for endangering or injuring themselves, another person, or property. Disregard for safety policies and procedures, including proper use of safety gear, clothing or equipment.
- Cooperation with Employees, the Public and Other Officials – Employees shall not engage in disorderly or abusive/violent conduct with other members and/or personnel from other City departments or agencies as well as the public.
- Safe Driving – The driver of any City vehicle shall operate said vehicle in a reasonable and safe manner, exercising due caution and judgment, following all state and federal traffic regulations, including the mandatory use of seatbelts within City vehicles.
- Possession of Firearms or Explosives – Possession of firearms or explosives on City property are prohibited by City employees except by certified police officers, those certified by the Iowa Law Enforcement Academy and currently the Deputy Fire Chief.
- Reporting for Work – Employees shall be punctual in reporting for work at the time and place designated by their supervisor(s). Employees shall not provide a false excuse for an absenteeism for which pay is received.
- Employees are required to maintain valid driver’s license, and any endorsements required in said job description.
- Insubordination.

- Employees are required to maintain all licenses and/or certifications that are necessary to fulfill the requirements of the job.
- Violation of city or departmental rules, regulations, policies and procedures.
- Refusal or failure to answer questions in an internal investigation. If an employee answers questions in an internal investigation, then the information obtained during the investigation cannot be used in a criminal prosecution case against the employee.
- Supervisors should not engage in any inappropriate relationships with their employees.
- Employees shall not abuse sick leave or dependent sick leave.
- Smoking on the job or in any city vehicle except during breaks in a designated location.
- Fighting, or threatening violence in the workplace/
- Horseplay, boisterous or disruptive activity in the workplace or practical jokes that are carried too far.
- Any other act, which is not in the best interest of the City.

The Disciplinary process includes the following forms:

- Oral reprimand reduced to writing.
- Written reprimand.
- Suspension.
- Demotion.
- Termination

Depending on the severity of the misconduct, all or some of these progressive disciplinary steps may be waived and the employee may be terminated. Termination must be with the recommendation of the City Administrator or designee.

DEFINITIONS: For a period of time during which the employee will not be working for the City of Ottumwa.

1. Punishment – suspension carries with it a censure for misconduct on the part of the employee.
 2. Pay – during the suspension the employee will receive no pay.
 3. Return To Work – return to work after the suspension is at the sole discretion of the City.
- Suspension is when an employee is suspended due to an act or behavior that is unacceptable by the Employer.

1. Employee will be placed on suspension.
2. Employee will receive no pay while on said suspension.
3. Return to work after the suspension at the sole discretion of City.

Layoff is when an employee is placed on lay-off status due to the reduction in the employees regularly scheduled work hours.

1. No punishment.
2. Employee could be eligible for unemployment benefits and could utilize any accumulated leave, excluding sick leave.
3. Sole discretion of the City.

ARTICLE 26. GRIEVANCE PROCEDURE

Definition. A grievance is defined as a timely filed claim by an employee which alleges that there has been a violation of the employee's rights. Should an employee claim a grievance, it shall be processed in the following manner:

Informal Step. The employee shall first discuss the problem with the immediate supervisor in an attempt to resolve the problem informally. If the problem is not settled to the employee's satisfaction, the following procedure should be used.

Step one. An employee who claims a grievance shall reduce the grievance to writing by giving and signing a statement of facts. The written grievance must be submitted to the immediate supervisor no later than seven (7) working days after the occurrence upon which the grievance is based or the grievance is waived. The immediate supervisor shall give a written answer to the aggrieved employee within seven (7) working days after the grievance is presented to the supervisor.

Step Two. If the grievance is not settled in Step One and the grievant wishes to take the grievance forward, the grievant must submit the signed grievance to the Department Head or his designee within seven (7) working days after receipt of the immediate supervisor's written answer or the grievance is waived. The Department Head will give a written answer to the aggrieved employee within seven (7) working days after the grievance is presented to the Department Head.

Step Three. If the grievance is not settled in Step Two, the grievant may submit the grievance to the Personnel Officer and the City Administrator within seven (7) working days of the receipt of the Department Head's written answer or the grievance is waived.

The City Administrator shall give a written answer to the aggrieved employee within ten (10) working days after the grievance is presented.

All completed copies of the grievance shall be forwarded to Human Resources and placed in the employee's personnel file.

A Civil Service employee shall request a hearing before the Civil Service Commission according to Chapter 400, Code of Iowa, if applicable. The Civil Service Commission shall decide whether or not the grievance is within the scope of the Commission's responsibilities prior to agreeing to hear the grievance.

ARTICLE 27 – EMPLOYEE PRIVACY

Employees have a reasonable expectation that offices, desks, lockers, file cabinets, etc. that are assigned to them will not be exposed to indiscriminate examination by other employees. However, the City does retain the right to enter an employee's office, desk, file cabinets, etc. for work related purposes.

No employee shall enter another employee's office, desk, file cabinet, locker, or similar "private" area, unless:

1. Authorized by the person who has control of the office or equipment;
2. Necessary for the proper conduct of City business;
3. Authorized by a Supervisor/Department Head for the purpose of investigating employee misconduct;
4. Part of an inspection; or
5. In response to an emergency situation.

Employees are cautioned that personal items may be inadvertently observed during the above situations. If an employee is concerned that this may happen, personal items should be stored elsewhere.

ARTICLE 28 – VIOLENCE IN THE WORKPLACE

The City of Ottumwa does not tolerate violence in any form or the threat or perception of violence by or against any employee while performing his or her official duties, or due to the employee's official duties, wherever those duties are performed. Additionally, the City of Ottumwa recognizes an individual's right to bear arms in accordance with state and federal laws afforded by the Second Amendment of the United States Constitution and the State of Iowa. The City is not liable for any wrongful or negligent act or omission related to actions of persons or employees who carry a concealed weapon.

Unless specific job duties require it, the ability to carry a concealed weapon is not within the scope of employment and is not a condition of employment. Nothing in this policy should be interpreted to require or encourage any employee who lawfully possesses a weapon to use it in defense of others.

An employee in violation of this policy will be subject to discipline up to and including termination of employment.

For additional information regarding the City of Ottumwa's expectations of its employees who wish to carry a concealed weapon while engaged in the duties of their employment, please reference the Workplace Violence and Threats Prevention Policy.

ARTICLE 29 – DRESS CODE

CITY HALL EMPLOYEES:

Business Attire Policy: Business Casual Dress Code:

The City of Ottumwa expects its City Hall employees to dress appropriately in business casual attire. Because our work environment serves customers, professional business casual attire is essential. Customers make decisions about the quality of our services to the community based on their interaction with you. Employees must be neat, clean and well-groomed with proper hygiene.

Consequently, business casual attire includes suits, dress pants, capris, jackets, shirts, skirts and dresses that, while not formal, are appropriate for a business environment. Examples of appropriate business attire include a polo shirt with pressed khaki pants, a sweater and shirt with corduroy pants, and a jacket, sweater, and skirt and leggings as part of a dressy ensemble and with a top that covers the rear end. Jeans, t-shirts, shorts, short skirts, tube tops, tank tops with shoulder strap width of 3 inches or less, and spaghetti straps (unless covered by a jacket), halter tops, low-cut blouses or sweaters, low cut shirts, blouses and sweaters, spandex or Lycra, clothing that is tight and suggestive, sweatpants, workout gym clothing, swim wear, and footwear such as flip flops are not appropriate for business casual attire. Open toed dress sandals for women are appropriate unless as directed by the Department Head due to the need to perform field inspections or work responsibilities outside of the office.

Be considerate and thoughtful regarding clothing that other employees might find offensive or that might make coworkers uncomfortable. This includes clothing with profane language statements or clothing that promotes causes that include, but are not limited to, politics, religion, sexuality, race, age, gender, and ethnicity. Clothing may not be revealing, in disrepair (torn, ripped or ragged) and cannot promote alcohol or tobacco products, violence or sexually suggestive or lewd written or visually suggestive images.

Employees are expected to demonstrate good judgment and professional taste. Courtesy of coworkers and your professional image to customers should be the factors that are used to assess that you are dressing in business attire that is appropriate.

Although it is impossible to establish an absolute dress and appearance code, the City of Ottumwa will apply a reasonable and professional workplace standard to individuals on a case-by-case basis. Management may make exceptions for special occasions or in the case of inclement weather, at which time employees will be notified in advance. An employee unsure of what is appropriate should check with his or her department head.

City Hall staff performing field inspections should wear clothing commensurate with the tasks they are performing, keeping in mind that attire should project a professional image. Staff may wear trousers, jeans, knit shirts with collars, city logo shirts and dress shirts. Attire should be clean, in good repair and suitable to employees in a professional position. Jeans are permitted if the staff member is actually performing field inspections or as approved by the Department Head. Closed toed shoes, as designated by the Department Head, are required.

Visible tattoos are permissible. However, any tattoo that would include profane language, promote alcohol or tobacco products, violence or sexually suggestive or lewd written or visually suggestive images should be covered. Tattoos on the face will not be permissible. Tattoos on the chest shall be covered.

Nose rings, eyebrow rings, gauge earrings, lip rings or studs are prohibited and cannot be worn in the workplace. Gauge earrings will need to be removed and have nude or clear plugs inserted while working. Earrings and small nose studs are allowed. Tongue piercings are permissible if they do not interfere with clear speech. Other visible body piercings are prohibited.

Every effort will be made to reasonably accommodate employees with a disability or with religious beliefs that may make it difficult for that employee to comply fully with the dress code policy. Employees should contact the City Administrator to request such a reasonable accommodation. The City will reasonably accommodate a staff member in terms of workplace attire unless the accommodation creates an undue hardship such as safety issues.

When applicable, protected concerted activity covered by the National Labor Relations Act (NLRA) or a City collective bargaining agreement is not prohibited by this policy. Wearing union insignia or displaying a union logo on clothing may be viewed as a form of protected concerted activity.

Employees who wear business attire that is deemed inappropriate in this workplace will be dealt with on an individual basis rather than subjecting all employees to a more stringent dress code for appropriate business attire. If a supervisor or Department Head decides that an

employee's dress or appearance is not appropriate as outlined in this policy, he or she may take corrective action and require the employee to leave the work area and make the necessary changes to comply with the policy. Hourly paid staff members will not be compensated for any work time missed because of a failure to comply with designated workplace attire and grooming standards.

Employees may face more severe consequences up to and including termination if they violate the dress code repeatedly.

Business Attire Policy: Casual Dress Code:

The City of Ottumwa will allow employees to dress appropriately in business attire of a casual nature on Fridays. On this day of the week, employees may wear jeans which are appropriate, not ripped, torn or revealing. We expect that your business attire, although casual, will exhibit common sense and professionalism.

Employees are expected to demonstrate good judgment and professional taste. Courtesy to coworkers and your professional image to coworkers should be the factors that are used to assess that you are dressing in business attire that is appropriate.

In addition, at the discretion of the City Administrator, in special circumstances, such as during unusually hot or cold weather or during special occasions, staff members may be permitted to dress casually. On these occasions, staff members are still expected to present a neat appearance and are not permitted to wear ripped, frayed or disheveled clothing or athletic wear. Likewise, tight, revealing or otherwise workplace-inappropriate dress is not permitted.

Employees who wear business attire that is deemed inappropriate in this workplace will be dealt with on an individual basis rather than subjecting all employees to a more stringent dress code for appropriate business attire.

Council Meetings:

Business Attire Policy: Formal Dress Code:

The City of Ottumwa expects employees to dress appropriately in business attire during Council meetings and work sessions. Because these meetings are televised, professional business attire is essential to promote the professional competency of city staff.

Business attire includes suits, dress shirts and dress pants, dresses and skirts that are typical of business formal attire at work.

Employees are expected to demonstrate good judgment and professional taste. Courtesy of coworkers and your professional image to clients should be the factors that are used to assess that you are dressing in business attire that is appropriate.

Employees who wear business attire that is deemed inappropriate in this workplace will be dealt with on an individual basis rather than subjecting all employees to a more stringent dress code for appropriate business attire.

OTHER NON-CITY HALL CITY EMPLOYEES:

Certain staff members in the Fire, Police, and Transit departments have a separate dress code and require staff to wear specific uniforms or attire. Policies are in place for each of those departments.

Public Works, Parks, Airport, Landfill, Recycling and Water Pollution Control employees will be neat, clean and well-groomed with proper hygiene. Jeans, t-shirts and work shirts are appropriate. Foot wear will be according to that department's internal policy.

Do not wear anything that other employees might find offensive or that might make coworkers uncomfortable. This includes clothing with profane language statements or clothing that promotes causes that include, but are not limited to, politics, religion, sexuality, race, age, gender, and ethnicity. Clothing may not be revealing, in disrepair (torn, ripped or ragged) and cannot promote alcohol or tobacco products, violence or sexually suggestive or lewd written or visually suggestive images.

Employees are expected to demonstrate good judgment and professional taste. Courtesy of coworkers and your professional image to the public should be the factors that are used to assess that you are dressing appropriately.

Although it is impossible and undesirable to establish an absolute dress and appearance code, the City of Ottumwa will apply a reasonable and professional workplace standard to individuals on a case-by-case basis. Management may make exceptions for special occasions or in the case of inclement weather, at which time employees will be notified in advance. An employee unsure of what is appropriate should check with his or her department head.

Visible tattoos are permissible. However, any tattoo that would include profane language, promote alcohol or tobacco products, violence or sexually suggestive or lewd written or visually suggestive images should be covered. Tattoos located on the face will not be permissible. Tattoos located on the chest must be covered.

Nose rings, eyebrow rings, gauge earrings, lip rings or studs are prohibited and cannot be worn in the workplace. Gauge earrings will need to be removed and have nude or clear plugs while working. Earrings and small nose studs are allowed. Tongue piercings are permissible if they do not interfere with clear speech. Other visible body piercings are prohibited.

Every effort will be made to reasonably accommodate employees with a disability or with religious beliefs that may make it difficult for that employee to comply fully with the dress code policy. Employees should contact the City Administrator to request such a reasonable accommodation. The City will reasonably accommodate a staff member in terms of workplace attire unless the accommodation creates an undue hardship such as safety issues.

When applicable, protected concerted activity covered by the National Labor Relations Act (NLRA) or a City collective bargaining agreement is not prohibited by this policy. Wearing union insignia or displaying a union logo on clothing may be viewed as a form of protected concerted activity.

Employees who wear attire that is deemed inappropriate in this workplace will be dealt with on an individual basis rather than subjecting all employees to a more stringent dress code for appropriate attire. If a supervisor or Department Head decides that an employee's dress or appearance is not appropriate as outlined in this policy, he or she may take corrective action and require the employee to leave the work area and make the necessary changes to comply with the policy. Hourly paid staff members will not be compensated for any work time missed because of a failure to comply with designated workplace attire and grooming standards.

Employees may face more severe consequences up to and including termination if they violate the dress code repeatedly.

ARTICLE 30 – CONFLICTS OF INTEREST

Employees have an obligation to conduct City business within guidelines that prohibit actual or potential conflicts of interest. An actual or potential conflict of interest occurs when an employee is in a position to influence a decision that may result in a personal gain for that employee or for a relative as a result of the City's business dealings. For the purposes of this policy, a relative is any person who is related by blood or marriage or whose relationship with the employee is similar to that of persons who are related by blood or marriage.

No "presumption of guilt" is created by the mere existence of a relationship with outside firms. However, if employees have any influence on transactions involving purchases, contracts, or leases, it is imperative that they disclose to the employee's supervisor as soon as possible the existence of any actual or potential conflict of interest so that safeguards can be established to protect all parties.

Personal gain may result not only in cases where an employee or relative has a significant ownership interest in a firm with which the City does business, but also when an employee or relative receives any kickback, bribe, substantial gift, or special consideration as a result of any transaction or business dealings involving the City. Specific questions can be addressed to the City Administrator.

ARTICLE 31 – SMOKING

Iowa's Smokefree Air Act prohibits smoking in any public place where the public is invited or permitted. Smoking is strictly prohibited in all enclosed areas within places of employment within the City, such as work areas, private offices, garages, hangars, conference and meeting rooms, classrooms, auditoriums, employee lounges, hallways, restrooms, elevators, stairways and stairwells, and any and all vehicles owned, leased, or provided by the City for use by City employees. Smoking is also prohibited while working on the job. Smoking may occur only during appropriate break times and in designated locations.

ARTICLE 32 – SUBSTANCE ABUSE POLICY

GENERAL POLICY:

The City of Ottumwa is committed to providing and maintaining a safe and healthy work environment free from the influence of alcohol and drugs. To that end, the City is adopting this Substance Abuse Policy.

The city recognizes that its own health and future is dependent upon the physical and psychological health of its employees. It is the right, obligation and intent of the City to maintain a safe, healthy and efficient working environment for all of its employees and to protect the public, as well as City property, equipment and operations.

The City also maintains an Employee Assistance Program which provides help to employees who seek assistance for alcohol or drug abuse and other personal or emotional problems.

With these basic objectives in mind, the City has established the following with regard to use, possession or sale of alcohol or drugs. Compliance with the City's Substance Abuse Policy is a condition of employment and covers all City employees whether or not they are covered by the Federal Motor Carrier Safety Administration or the Federal Transit Administration drug testing requirements. This zero tolerance policy covers alcohol as well as any illegal substance as defined by Iowa and/or Federal Statutes or Regulations. The City intends to take serious disciplinary

action, up to and including termination, against an employee who violates the City's Substance Abuse Policy.

SCOPE:

All employees.

TESTING:

Pre-Employment Testing:

1. All potential new employees, full-time, part-time, seasonal, temporary, job training workers and work release workers and any other employees covered by the City's workers' compensation policy shall be tested as a part of the City's pre-employment physical.
2. Notice of testing will be part of all notices of advertisement soliciting applicants for employment and on the application form. All applicants shall be verbally informed of the requirement during the first interview.

Federally Required:

The City is required to test employees who operate a commercial motor vehicle or employees who operate transit vehicles under the authority of the Federal Motor Carrier Safety Administration or the Federal Transit Authority. The City will comply with the requirements of the respective authority for the federal required test.

Reasonable Suspicion:

The City may require a specific employee to submit to a drug test if all of the following conditions are met:

1. The employer has reasonable suspicion to believe that an employee's faculties are impaired on the job; and
2. The employee is in a position in which such impairment presents a danger to the safety of another employee, a member of the public or City property.

Reasonable suspicion may include direct observation of alcohol or drug use or abuse or of the physical symptoms of being impaired due to alcohol or drug use at work; abnormal conduct or erratic behavior while at work or a significant deterioration in work performance; report of alcohol or drug use provided by a reliable and credible source; or evidence that an employee has manufactured, sold, distributed, solicited, possessed, used or transferred drugs while working or while on City property or while operating City vehicles, machinery or equipment.

Post Accident:

The City may require an employee not covered by DOT requirements to submit to a drug test if the employee has caused an accident while at work which resulted in injury which, if suffered by an employee, would require an OSHA report or which resulted in damage to property in an amount reasonably estimated to exceed \$1,000.00.

GENERAL PROVISIONS:

Drug Test: Means any urine, saliva, breath or other legally allowed test conducted for the purpose of detecting the presence of a chemical substance in an individual.

List of Controlled Substances: This list includes all controlled substances including but not limited to the following: Amphetamines (including methamphetamines)

- Cocaine metabolite
- Opiates (Includes heroin)
- Phencyclidine (PCP)
- Marijuana (THC) metabolite

In addition, the City tests for Creatinine, Urinary, although this is not a controlled substance.

Time for Testing:

Tests will be conducted either during or immediately before or after an employee begins work. For employees subject to random testing under federal law, the employee will be tested during or immediately after performing these functions. Time for testing is considered work time and the employee will be compensated for the time it takes to provide a sample for testing. The City will either provide transportation for the employee to the collection site or pay for the transportation to the collection site.

Test Procedures:

Samples provided will be collected in reasonable and sanitary conditions with regard for the privacy of the individual providing the sample and for the validity of the test. Samples (other than breath samples) will be split in the presence of the individual to allow for confirmatory testing of any initial positive test result. The collection site and laboratory will follow standard chain-of-custody procedures for samples for the time of collection until the sample is no longer needed.

1. The test sample will be collected at Collaborative Laboratory Services, 1005 Pennsylvania Avenue, Ottumwa, Iowa, or such other site directed by law enforcement in the event the employee is involved in an accident requiring testing.
2. The test sample withdrawn from the employee will be analyzed by a laboratory or testing facility that has been approved under rules adopted by the Iowa Department of Public Health.

3. If an employee provides a sample that is dilute, the employee will be required to immediately report for another test. That test will be done under direct observation if required by DOT regulations.
4. If an initial test is conducted and the results indicate that the employee has tested positive for alcohol or controlled substances, a confirmatory test using an alternative method of analysis shall be conducted. The confirmatory test shall use a portion of the same sample withdrawn from the employee for use in the initial test.
5. An employee shall be accorded a reasonable opportunity to rebut or explain the results of the drug test and to provide information which he or she thinks is relevant to the test. Such information may include identification of prescription or non-prescription drugs the individual is using or has recently used or any other relevant medical information.
6. The test result will first be reported to the City's MRO for review and interpretation. The MRO will then report the confirmed positive test result to the City's designated employer representative.
7. If an employee provides a sample that has been tampered with or substituted or is determined by the approved laboratory to have been tampered with or substituted, it will be treated the same as a positive test result.
8. The City will look to the rules and interpretations used by the United States Department of Transportation related to drug testing on any issues not specifically addressed in this policy and will follow the thresholds established by the approved laboratory for determination of whether the presence of a substance in a sample constitutes a positive test result.
9. Test results when reported to the City by its MRO will be maintained separate from the employee's other personnel records.

Refusal to Test: Refusal to test includes refusal to take the test, inability to provide adequate samples for testing without a valid medical explanation; tampering with or attempting to adulterate a sample; interfering with collection procedures; failing to immediately report to the collection site; failing to remain at the collection site until the collection process is complete; having a test result confirmed by the MRO as adulterated or substituted; or leaving the scene of an accident without a valid reason before a test has been conducted.

Designated Employer Representative: The City's Human Resources Officer shall be the City's designated employer representative for receipt of drug and alcohol test results.

Medical Review Officer: The City contracts with St. Luke's Iowa Health System for these services.

Supervisor Training: The City will comply with the DOT training requirements for supervisors which includes two hours of initial training, one hour of which will be related to controlled substances and one hour to alcohol misuse.

Testing Costs: The City will bear the costs of all testing required under this policy, including a second confirmatory test requested by an employee who has tested positive.

Prevention and Treatment: The City encourages any employee with a drug or alcohol problem to voluntarily seek treatment. The City has established an Employee Assistance Program to provide counseling and referral services for employees with drug or alcohol abuse problems who voluntarily seek help. Conscientious efforts to seek and use such help will not jeopardize an employee's job.

Prohibited Conduct:

The City strictly prohibits unauthorized use, possession (including storage in a desk, locker, vehicle or other depository), manufacture, distribution, dispensing or sale of illegal drugs, drug paraphernalia, controlled substances or alcohol on City property, while on City business or in City supplied vehicles, or during working hours.

Any action taken against an employee shall be based only on the results of the drug and alcohol test. *Employees who violate any aspect of this policy may be subject to disciplinary action up to and including termination of employment. An employee's refusal to test will result in disciplinary action up to and including termination of employment.*

Departmental Policies:

Individual departments may adopt policies and procedures more stringent than these policies; but, in no event, shall they be less stringent.

Off-Duty Loss of Driving Privileges:

In addition to any other sanctions which may be invoked under this Policy, employees whose work with the City requires the employee to drive a City vehicle and who lose his/her driving privilege will be laid off from employment immediately. Reinstatement from such layoff will be dependent upon the City having an available position after the employee's driving privilege has been restored.

ARTICLE 33. TRAVEL

It is the policy of the City to define its position regarding travel of City employees for purposes of City business including attendance at conferences, workshops and seminars. The City encourages the advancement and enrichment of employees' professional expertise and technical skills. Necessary expenses incurred by City employees involved in the above mentioned activities will be paid by the City in those cases where the activity is a direct benefit to the City and where

attendance by the City employee at such activity will increase the employee's job performances. Exceptions to this policy must be approved by the City Administrator.

1. All City employees may perform official travel after preparing an Out of Area Travel Form and upon authorization of the Department Head and the City Administrator. The procedures for elected officials will be the same as all other employees, except that travel approval will be made by the Mayor. All travel must be requested prior to the occurrence of the trip and must state justification for such travel.
2. Transportation costs for employees authorized to travel on official City business shall be paid by the City. The least expensive method of booking travel and lodging will be used with the bills going directly to the City if possible. The use of the City's credit card should be utilized by the department head to pay for the lodging when applicable.
 - a. Mileage will be paid to and from the appropriate destination and Ottumwa if the employee uses their personal vehicle. If air travel is involved, mileage will be paid to the appropriate airport. Google maps should be utilized to obtain the mileage. This does not need to be printed out. Finance will verify when the travel form is processed.
 - b. Costs for parking a city vehicle or privately owned vehicle will be reimbursed by the City upon presentation of appropriate receipts.
 - c. Taxicab/Uber type fares will be reimbursed as appropriate.
 - d. For in state travel, a city vehicle will be used when practical. The employee may get a gasoline credit card issued to the City from the Finance Department to be used for fuel and emergency auto repairs only. When travel is by personal vehicle, mileage will be paid at the rate established by the Internal Revenue Service.
3. The City will reimburse for meal expenses as follows:
 - a. The meal allowance shall be up to \$8.00 for breakfast, \$12.00 for lunch and \$22.00 for dinner in the State of Iowa. Detailed receipts will be required to receive reimbursement for meals. If a meal is provided as part of the conference, training or seminar registration, the employee will not be reimbursed for that meal. An employee will only be reimbursed for breakfast when the starting time of the trip is before 6:00 am. and for dinner if the return is after 8:00 p.m. Under no circumstances will alcohol be reimbursed as part of a meal allowance.
4. Also included as reimbursable costs are those incurred for registration and lodging.
 - a. All employees attending conferences and seminars will pre-register with the City paying the registration fee directly. A memo requesting payment should be prepared stating the reason for the individuals attending the conference, the names of the individuals attending and an original and copy (for submission) of the official registration.

- b. Lodging costs shall be paid by the City at the single rate only when the spouse accompanies the employee. Telephone calls incidental to the performance of official business only shall be reimbursable.
 - c. If the starting time required is such that the Department Head deems necessary, the employee may begin the trip the day before and be reimbursed for the preceding night's lodging costs and any other incidental costs.
 - d. Employees on official City business may request a travel advance prior to the occurrence of the trip. Requests for advance travel funds shall be submitted at least 10 working days prior to the occurrence of the conference or meeting. Advances will be released to the employee the day before actual travel is to begin. Advances for less than \$50 will not be made.
 - e. All travel receipts must accompany the Final Travel form before reimbursement. All forms and receipts must be turned into the Finance Department within five days of return to work.
5. City employees traveling on City business within the corporate city limits and using their personal vehicle will be required to document their travel using an In City Travel Form.
6. Employees traveling on behalf of the City shall be paid for all hours worked pursuant to the Fair Labor Standards and pursuant to any applicable collective bargaining agreement.

ARTICLE 34. SEPARATION FROM CITY SERVICE

All employees voluntarily leaving employment with the City of Ottumwa must give at least two weeks written notice prior to the effective date. If an employee is retiring, written notice must have retirement date and address change if applicable. If an employee resigns, the notice must contain employee's name, forwarding address, effective date and the reason for resignation. Written notice must be accompanied with Personnel Action Sheet to the City Administrator or designee.

Employees leaving City service shall return all property belonging to the employer to his/her immediate supervisor. All uniforms, tools, keys, equipment and department manuals will be given to employee's immediate supervisor before receiving employee's last payroll check. Until City property is returned, the employee will not receive any payment for accrued leave the employee might otherwise be entitled to.

Employees leaving city services may be required to have an exit interview with The City Administrator or designee.

Employees leaving employment with the City shall not be allowed to take accrued leave after their last actual working day with the City. All accrued leave will be paid out thereafter the first pay period following the employee's final pay check for time actually worked. Accrued leave does not include sick leave.

received
6-13-23 1145A

Item No. I.-3

CITY OF OTTUMWA Staff Summary

**** ACTION ITEM ****

Council Meeting of: June 20, 2023

Jake Rusch

Prepared By

Building and Code Enforcement

Department

Zach Simonson

Department Head



City Administrator Approval

AGENDA TITLE: Resolution No.94-2023. A resolution awarding the contract for Asbestos abatement and demolition of the condemned property at 1054 and 1056 Tuttle.

****Public hearing required if this box is checked.****

The Proof of Publication for each Public Hearing must be attached to this Staff Summary. If the Proof of Publication is not attached, the item will not be placed on the agenda.

RECOMMENDATION: Pass and Adopt Resolution 94-2023

DISCUSSION: Bids for this project were accepted until 2 P.M. on May 18, 2023. Four demolition bids were received. Dustin Smith had the lowest bid in the amount of \$7,200 for demolition. Staff recommends awarding him the contract. A bid tab is attached.

Source of Funds: 151-3-342-6499

Budget Item: Budget Amendment Needed

RESOLUTION NO. 94-2023

A RESOLUTION AWARDED THE CONTRACT FOR ASBESTOS ABATEMENT AND DEMOLITION OF THE CONDEMNED PROPERTY AT 1054 AND 1056 TUTTLE.

WHEREAS, the City of Ottumwa has accepted bids for the above referenced project until 2pm on May 18, 2023; and

WHEREAS, the lowest qualified bid was from Dustin Smith in the amount of \$7,200 for demolition and leveling of the lot.

NOW THEREFORE, BE IT RESOLVED, BY THE CITY COUNCIL OF THE CITY OF OTTUMWA IN THE STATE OF IOWA THAT:

Dustin Smith be awarded the contract for demolition of the condemned property at 1054 and 1056 Tuttle in the amount of \$7,200 for demolition and leveling of the lot.

APPROVED, PASSED AND ADOPTED this 20th day of June 2023.

CITY OF OTTUMWA, IOWA

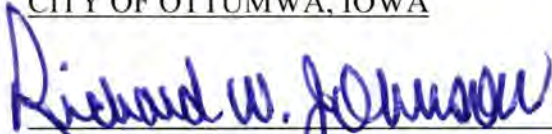
Richard W. Johnson, Mayor

ATTEST:



Christina Reinhard, City Clerk

| 1054 and 1056 Tuttle | Asbestos | Demolition | Total |
|--------------------------------|----------|------------|------------|
| Dustin Smith | | 7,200 | \$7,200.00 |
| Torres Construction | | 7,280 | \$7,280.00 |
| Weston McKee | | \$7,700.00 | \$7,700.00 |
| Weston McKee | | \$7,800.00 | \$7,800.00 |
| Best Bid For Demolition | | | |
| Is Dustin Smith | | | \$7,200 |

S Initial Form Here



CITY OF
OTTUMWA

REQUEST BID FOR DISPOSAL AND DEMOLITION OF 1054 AND 1056
TUTTLE STREET OTTUMWA, IOWA

BID FORM

| Address | | Demolition Bid | TOTAL BID |
|----------------------------|--|----------------------|----------------------|
| 1056 AND 1054 TUTTLE | | 7,200. ⁰⁰ | 7,200. ⁰⁰ |
| | | | |
| | | | |
| | | | |

_____ Initial here if you are willing to have individual portions of your bid considered for award.

It is understood that the City reserves the right to accept or reject any or all proposals, to disregard any formality in connection therewith, or to accept any proposal, which in its opinion, is in the best interest of the City.

A Bid Security must be included in the sealed bid envelope along with this bid sheet. The bid security must equal ten percent (10%) of the total bid price and must be in the form of cash or a cashier's check or as a certified check drawn on a bank in Iowa or chartered in the United States, or a certified share draft drawn on a credit union chartered under the laws of the United States.

The Successful Bidder shall then provide a performance bond with corporate surety to one hundred percent (100%) of the bid price on all projects. A cashier's check, a certified share

DS Initial Form Here

draft, as described above or cash may be used. An irrevocable letter of credit stating the amount of the project for an amount equal to 100% of the bid price may be substituted for the performance bond.

The Bid Form and Work Required document automatically become part of the final contract should this proposal be accepted.

If my proposal is accepted, I, the undersigned, agree to enter into a contract (see attached sample) for said work.

Signature

Dustin Smith
Printed Name

2801 Boomer Ave
Address

641-226-4483
Telephone Number

Ottumwa IA 52501
City, State, Zip

5-18-23
Date

dustin.p@msn.com
E-mail Address

received
6-13-23 1145A

Item No. I.-4

CITY OF OTTUMWA Staff Summary

**** ACTION ITEM ****

Council Meeting of: June 20, 2023

Jake Rusch

Prepared By

Building and Code Enforcement

Department

Zach Simonson

Department Head

City Administrator Approval

AGENDA TITLE: Resolution No.95-2023. A resolution awarding the contract for Asbestos abatement and demolition of the condemned property at 301 N Graves.

****Public hearing required if this box is checked.****

The Proof of Publication for each Public Hearing must be attached to this Staff Summary. If the Proof of Publication is not attached, the item will not be placed on the agenda.

RECOMMENDATION: Pass and Adopt Resolution 95-2023

DISCUSSION: Bids for this project were accepted until 2 P.M. on May 18, 2023. Three Asbestos bids and three demolition bids were received. Dan Laursen submitted the best bids in the amount of \$6,800 for Asbestos and \$18,000 for demolition. Staff recommends awarding him the contract. A bid tab is attached.

RESOLUTION NO. 95-2023

A RESOLUTION AWARDING THE CONTRACT FOR ASBESTOS ABATEMENT AND DEMOLITION OF THE CONDEMNED PROPERTY AT 301 N GRAVES.

WHEREAS, the City of Ottumwa has accepted bids for the above referenced project until 2pm on May 18, 2023; and

WHEREAS, the lowest qualified bid was from Dan Laursen in the amount of \$6,800 for asbestos abatement and \$18,000 for demolition and leveling of the lot.

NOW THEREFORE, BE IT RESOLVED, BY THE CITY COUNCIL OF THE CITY OF OTTUMWA IN THE STATE OF IOWA THAT:

Dan Laursen be awarded the contract for asbestos abatement and demolition of the condemned property at 301 N Graves in the amount of \$6,800 for asbestos abatement and \$18,000 for demolition and leveling of the lot.

APPROVED, PASSED AND ADOPTED this 20th day of June 2023.

CITY OF OTTUMWA, IOWA

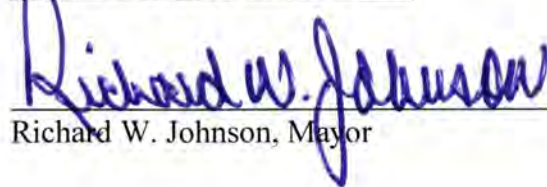
Richard W. Johnson, Mayor

ATTEST:



Christina Reinhard, City Clerk

| 301 N Graves | Asbestos | Demolition | Total |
|--|-----------------|-------------------|-----------------|
| Dan Laursen | \$6,800.00 | \$18,000.00 | \$24,800.00 |
| Weston McKee | \$14,000.00 | \$14,000.00 | \$28,000.00 |
| Dustin Smith | \$20,000.00 | \$18,000.00 | \$38,000.00 |
| Best Bid For Demolition and Asbestos removal Is Dan Laursen | | | \$24,800 |

JL Initial Form Here

ap
ar



CITY OF
OTTUMWA

REQUEST BID FOR ASBESTOS REMOVAL AND DISPOSAL AND
DEMOLITION OF 301 N GRAVES STREET OTTUMWA, IOWA

BID FORM

| Address | Asbestos Bid | Demolition Bid | TOTAL BID |
|--------------|------------------------|-------------------------|-------------------------|
| 301 N GRAVES | \$ 6,800 ⁰⁰ | \$ 18,000 ⁰⁰ | \$ 24,800 ⁰⁰ |
| | | | |
| | | | |
| | \$ 6,800 ⁰⁰ | \$ 18,000 ⁰⁰ | \$ 24,800 ⁰⁰ |

_____ Initial here if you are willing to have individual portions of your bid considered for award.

It is understood that the City reserves the right to accept or reject any or all proposals, to disregard any formality in connection therewith, or to accept any proposal, which in its opinion, is in the best interest of the City.

A Bid Security must be included in the sealed bid envelope along with this bid sheet. The bid security must equal ten percent (10%) of the total bid price and must be in the form of cash or a cashier's check or as a certified check drawn on a bank in Iowa or chartered in the United States, or a certified share draft drawn on a credit union chartered under the laws of the United States.

The Successful Bidder shall then provide a performance bond with corporate surety to one hundred percent (100%) of the bid price on all projects. A cashier's check, a certified share draft, as described above or cash may be used. An irrevocable letter of credit stating the

amount of the project for an amount equal to 100% of the bid price may be substituted for the performance bond.

The Bid Form and Work Required document automatically become part of the final contract should this proposal be accepted.

If my proposal is accepted, I, the undersigned, agree to enter into a contract (see attached sample) for said work.

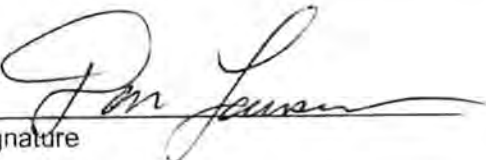
Signature

DAN LAURSON
Printed Name

510 MORRELL DRIVE
Address

641-799-3818
Telephone Number

OTTUMMA - IA 52501
City, State, Zip

MAY 18TH 2023
Date

DANLAURSON44@YAHOO.COM
E-mail Address

received
6.14.23 4:30p.

CITY OF OTTUMWA

Staff Summary

**** ACTION ITEM ****

Council Meeting of : Jun 20, 2023

Planning & Development
Department

Zach Simonson
Prepared By
Zach Simonson
Department Head



City Administrator Approval

AGENDA TITLE: RESOLUTION NO. 99-2023 - A RESOLUTION APPROVING THE FINAL PLAT OF CHRISTNER'S FIRST SUBDIVISION IN THE CITY OF OTTUMWA, WAPELLO COUNTY, IOWA

Public hearing required if this box is checked.

RECOMMENDATION: Pass and adopt Resolution No. 99-2023.

DISCUSSION: The applicant is requesting approval of a .94-acre, four lot, contiguous area to be subdivided into four new lots. Currently, this block is divided into four parcels which run east to west with frontage on Oak St. The new subdivision would create four parcels which run north to south and would have frontage on E Court and Lincoln Ave. The subdivision will allow for the construction of new single-family homes.

Source of Funds:

Budgeted Item: Budget Amendment Needed:

RESOLUTION NO. 99-2023

A RESOLUTION APPROVING THE FINAL PLAT OF CHRISTNER'S FIRST SUBDIVISION IN THE CITY OF OTTUMWA, WAPELLO COUNTY, IOWA

WHEREAS, Christner's First Subdivision, City of Ottumwa, Wapello County, Iowa, is being described as follows, to-wit:

Lots Thirty-four (34), Lot Thirty-five (35), Lot Thirty-six (36), and Lot Thirty-seven (37) in East Ottumwa, an addition to the City of Ottumwa, Wapello County, Iowa.

WHEREAS, the Ottumwa Planning and Zoning Commission recommended approval of the Kiple's Second Subdivision Final Plat at its June 5th, 2023 meeting; and

NOW, THEREFORE, be it resolved by the City Council of the City of Ottumwa, Iowa:

That the Final Plat known as Christner's 1st Subdivision, City of Ottumwa, Wapello County, Iowa, is hereby accepted, and the Mayor and the City Clerk are hereby authorized to sign the plat and attest to the same and certify a true copy of this Resolution to the County Recorder of Wapello County, Iowa, as provided by law and all other public officers as required by law.

Passed and adopted this 20th day of June 2023.

CITY OF OTTUMWA, IOWA

By

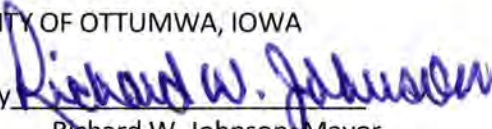
Richard W. Johnson, Mayor

ATTEST:

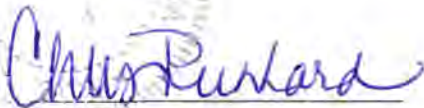
Chris Reinhard, City Clerk

FINAL PLAT - CHRISTNER'S 1ST SUBDIVISION

APPROVED BY: _____ DATE _____
 CITY OF OTTUMWA - CITY COUNCIL

APPROVED BY: _____ DATE _____
 CITY OF OTTUMWA - PLANNING & ZONING

APPROVED BY: _____ DATE _____
 CITY OF OTTUMWA - CITY ENGINEER

CHRISTNER'S 1ST SUBDIVISION:

Lots Thirty-four (34), Lot Thirty-five (35), Lot Thirty-six (36), and Lot Thirty-seven (37) in East Ottumwa, an addition to the City of Ottumwa, Wapello County, Iowa.

REFERENCE SURVEYS

Plot of Survey prepared by Lewis E. Graham, Jr. for Mark Stephen and Karen Elaine Douglas on February 20, 1992.

Plot of Survey prepared by John T. Brady, Sr. dated October 6, 1907. Field notes from this survey indicate a shortage of 18.0 feet between the East Line of N Elm St and the East Line of the Alley on the Section Line East of Fellows Ave. as measured along the North Line of E Court St.

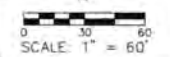
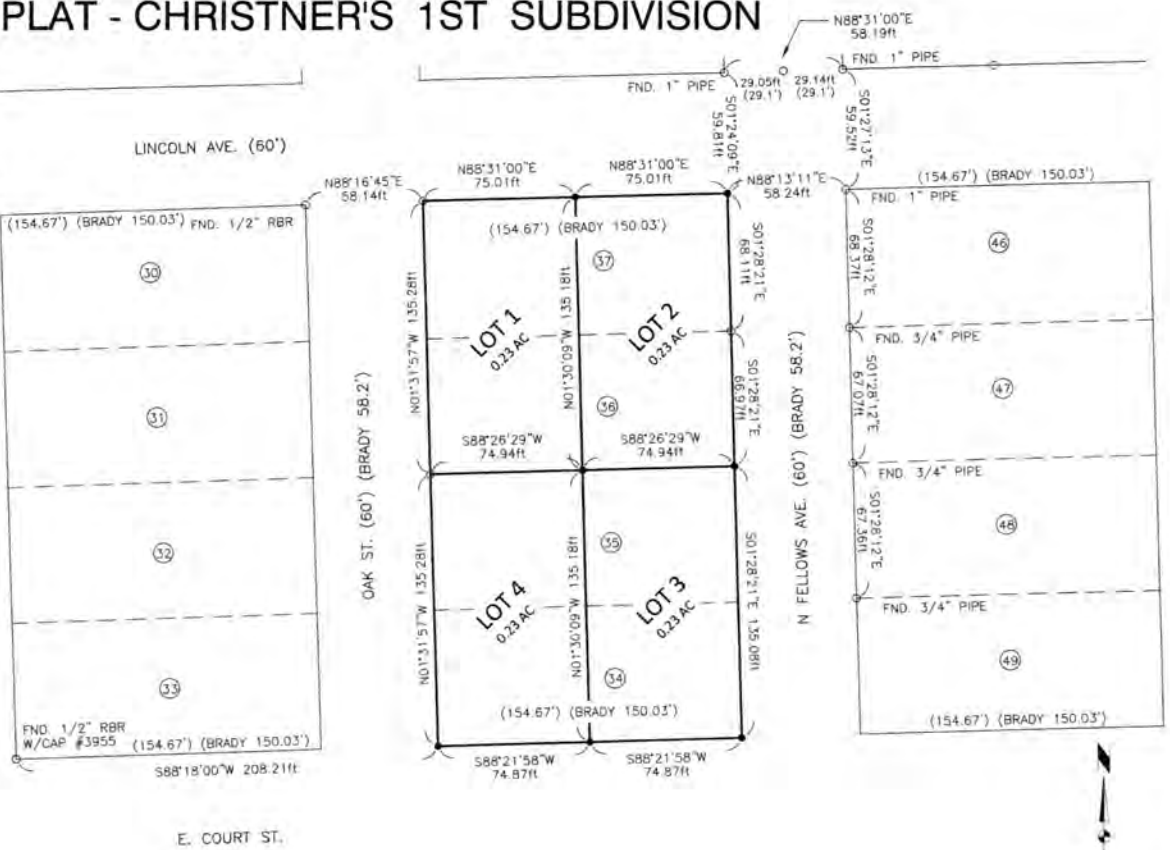

* ALL BEARINGS AND DISTANCES ARE THE RESULT OF GPS OBSERVATIONS, IOWA RCS, ZONE 12 *

Prepared by & Return to: French-Reneker-Associates, Inc., 1501 S. Main St., Fairfield, IA 52556. Phone: (641) 472-5145. Surveyor: Jason C. Hull

OWNER: CHRISTNER PROPERTIES, LLC
 17587 US HWY 34
 OTTUMWA, IOWA 52501

PLANNERS: FRENCH-RENEKER ASSOCIATES
 1501 S. MAIN ST
 FAIRFIELD, IOWA 52556

I hereby certify that this land surveying document was prepared and the related survey work was performed by me or under my direct personal supervision and that I am a duly licensed Land Surveyor under the laws of the State of Iowa.

Jason C. Hull 5-12-23
 Jason C. Hull, P.L.S. date
 License number 15943
 My license renewal date is December 31, 2024
 Pages or sheets covered by this seal. This Sheet



| | |
|---------------------------------------|--------------------------------------|
| County: WAPELLO | City: OTTUMWA |
| Section: N/A Township: N/A Range: N/A | Subdivision: EAST ADDITION |
| Aliquot Part: N/A | Block: N/A |
| Lot(s): 34, 35, 36, 37 | Proprietor: CHRISTNER PROPERTIES LLC |
| Requested By: ANTHONY CHRISTNER | |

| | | |
|---------------|---|--|
| LEGEND: | FOUND SQUARE HEAD BOLT UNLESS OTHERWISE NOTED | SET 5/8"x30" REBAR W/ORANGE PLASTIC CAP #15943 |
| | | |
| | | |
| | | |
| Drawn By: BPH | Date: 4-26-23 | Project No: 23-334 |
| Sheet: 1 of 1 | | |



received
6-14-23 4pm

Item No. L-6

CITY OF OTTUMWA

Staff Summary

**** ACTION ITEM ****

Council Meeting of: Jun 20, 2023

Park & Recreation
Department

Gene Rathje
Prepared By
Gene Rathje
Department Head



City Administrator Approval

AGENDA TITLE: Resolution #100-2023, Accepting the Work as Final and Complete and Approving the Final Pay Request for the Ottumwa Park Campground Shower House and Office Project.

Public hearing required if this box is checked.

RECOMMENDATION: Pass and Adopt Resolution #100-2023.

DISCUSSION: The Ottumwa Park Campground Office and Shower House project is now complete, and the 5% retainage payment of \$29,742,10 can be made to the contractor, RG Construction of Ottumwa. The total cost of this project with RG Construction was \$594,842. The final pay request from RG Construction is attached as well as the certificate of project completion from Willett Hoffman.

Source of Funds: CIP, Grants, ARPA Funds

Budgeted Item: Budget Amendment Needed: No

RESOLUTION # 100-2023

A RESOLUTION ACCEPTING THE WORK AS FINAL AND COMPLETE AND APPROVING THE FINAL PAY REQUEST FOR THE CAMPGROUND SHOWER HOUSE AND OFFICE PROJECT

WHEREAS, The City Council of the City of Ottumwa, Iowa entered into a contract with RG Construction of Ottumwa, Iowa on June 21, 2022 for the above referenced project, and

WHEREAS, This project is now final and complete and the project can be closed out and final payment can be made.

NOW, THEREFORE, BE IT RESOLVED BY THE CITY COUNCIL OF THE CITY OF OTTUMWA, IOWA :

The Ottumwa Park Campground Shower House and Office Project is hereby accepted as final and complete and authorization to make final payment to RG Construction of Ottumwa Iowa in the amount of \$29,742.10 is hereby approved.

APPROVED, PASSED, AND ADOPTED, this 20th day of June, 2023.

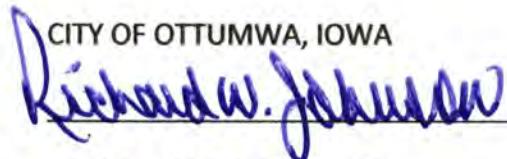
CITY OF OTTUMWA, IOWA

Richard W. Johnson, Mayor

ATTEST:

Christina Reinhard, City Clerk

Christina Reinhard, City Clerk

AIA® Document G704® – 2017

Certificate of Substantial Completion

| | | |
|--|--|---|
| PROJECT: <i>(name and address)</i> Ottumwa Campground Showerhouse 1 Joe Lord Memorial Dr, Ottumwa, IA 52501 | CONTRACT INFORMATION: Contract For: City Campground Shower and Office Facility Date: June 21, 2022 | CERTIFICATE INFORMATION: Certificate Number: 001 Date: March 31, 2023 |
| OWNER: <i>(name and address)</i> City of Ottumwa 105 East 3rd Street, Ottumwa, IA 52501 | ARCHITECT: <i>(name and address)</i> Willett Hofmann & Associates 625 32nd Ave SW, Cedar Rapids, IA 52404 | CONTRACTOR: <i>(name and address)</i> RG Construction Inc 215 East 4th Street, Ottumwa, IA 52501 |

The Work identified below has been reviewed and found, to the Architect's best knowledge, information, and belief, to be substantially complete. Substantial Completion is the stage in the progress of the Work when the Work or designated portion is sufficiently complete in accordance with the Contract Documents so that the Owner can occupy or utilize the Work for its intended use. The date of Substantial Completion of the Project or portion designated below is the date established by this Certificate.

(Identify the Work, or portion thereof, that is substantially complete.)

The City Campground Shower and Office facility is substantially complete and can be used for its intended purpose.

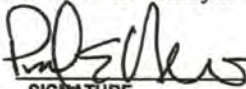
| | | | |
|------------------------------|---|-----------------------------------|--------------------------------|
| Willett Hofmann & Associates |  | Paul E. Newman, Project Architect | March 31, 2023 |
| ARCHITECT <i>(Firm Name)</i> | SIGNATURE | PRINTED NAME AND TITLE | DATE OF SUBSTANTIAL COMPLETION |

WARRANTIES

The date of Substantial Completion of the Project or portion designated above is also the date of commencement of applicable warranties required by the Contract Documents, except as stated below:

(Identify warranties that do not commence on the date of Substantial Completion, if any, and indicate their date of commencement.)

WORK TO BE COMPLETED OR CORRECTED

A list of items to be completed or corrected is attached hereto, or transmitted as agreed upon by the parties, and identified as follows:
(Identify the list of Work to be completed or corrected.)

A list of items to be completed was transmitted to all parties on April 5, 2023 via e-mail

The failure to include any items on such list does not alter the responsibility of the Contractor to complete all Work in accordance with the Contract Documents. Unless otherwise agreed to in writing, the date of commencement of warranties for items on the attached list will be the date of issuance of the final Certificate of Payment or the date of final payment, whichever occurs first. The Contractor will complete or correct the Work on the list of items attached hereto within () days from the above date of Substantial Completion.

Cost estimate of Work to be completed or corrected: \$

The responsibilities of the Owner and Contractor for security, maintenance, heat, utilities, damage to the Work, insurance, and other items identified below shall be as follows:

(Note: Owner's and Contractor's legal and insurance counsel should review insurance requirements and coverage.)

The Owner and Contractor hereby accept the responsibilities assigned to them in this Certificate of Substantial Completion:

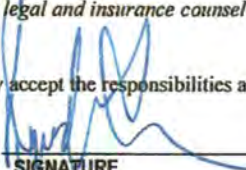
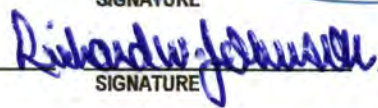
| | | | |
|-------------------------------|---|--------------------------|-----------|
| RG Construction, Inc |  | Red Grooms, OWNER | 5/31/2023 |
| CONTRACTOR <i>(Firm Name)</i> | SIGNATURE | PRINTED NAME AND TITLE | DATE |
| City of Ottumwa |  | Richard W. Johnson Mayor | 6/20/2023 |
| OWNER <i>(Firm Name)</i> | SIGNATURE | PRINTED NAME AND TITLE | DATE |

APPLICATION AND CERTIFICATE FOR PAYMENT

TO OWNER:
The City of Ottumwa
105 East 3rd Street
Ottumwa, IA 52501

PROJECT:
Campground Shower House & Office Building

APPLICATION #: 8 Retainage Distribution to:
PERIOD TO: 03/31/23
PROJECT NOS: 3011C21

| | |
|-------------------------------------|------------|
| <input checked="" type="checkbox"/> | Owner |
| <input type="checkbox"/> | Const. Mgr |
| <input checked="" type="checkbox"/> | Architect |
| <input checked="" type="checkbox"/> | Contractor |

FROM CONTRACTOR:
RG Construction, LLC
215 East 4th Street
Ottumwa, IA 52501

VIA ARCHITECT:
Willett Hofmann & Associates
625 32nd Avenue SW
Cedar Rapids, IA 52404

CONTRACT DATE: 06/21/21

CONTRACT FOR:

CONTRACTOR'S APPLICATION FOR PAYMENT

Application is made for payment, as shown below, in connection with the Contract.
Continuation Sheet is attached.

| | | |
|---|----|------------|
| 1. ORIGINAL CONTRACT SUM----- | \$ | 573,872.00 |
| 2. Net change by Change Orders----- | \$ | 20,970.00 |
| 3. CONTRACT SUM TO DATE (Line 1 +/- 2) | \$ | 594,842.00 |
| 4. TOTAL COMPLETED & STORED TO DATE-\$ (Column G on Continuation Sheet) | | 594,842.00 |
| 5. RETAINAGE: | | |
| a. 5.0% of Completed Work (Column D+E on Continuation Sheet) | \$ | 29,742.10 |
| b. 5.0% of Stored Material (Column F on Continuation Sheet) | \$ | |
| Total Retainage (Line 5a + 5b or Total in Column 1 of Continuation Sheet----- | \$ | 29,742.10 |
| 6. TOTAL EARNED LESS RETAINAGE----- (Line 4 less Line 5 Total) | \$ | 565,099.90 |
| 7. LESS PREVIOUS CERTIFICATES FOR PAYMENT (Line 6 from prior Certificate)----- | \$ | 565,099.90 |
| 8. CURRENT PAYMENT DUE----- | \$ | 29,742.10 |
| 9. BALANCE TO FINISH, INCLUDING RETAINAGE (Line 3 less Line 6) | \$ | |

| CHANGE ORDER SUMMARY | ADDITIONS | DEDUCTIONS |
|--|-------------|------------|
| Total changes approved in previous months by Owner | \$20,970.00 | |
| Total approved this Month | | |
| TOTALS | \$20,970.00 | |
| NET CHANGES by Change Order | \$20,970.00 | |

The undersigned Contractor certifies that to the best of the Contractor's knowledge, information and belief the Work covered by this Application for Payment has been completed in accordance with the Contract Documents, that all amounts have been paid by the Contractor for Work for which previous Certificates for Payment were issued and payments received from the Owner, and that current payment shown therein is now due.

CONTRACTOR:

By: RG Construction Date: 3/31/23

State of: Iowa
County of: Wapello

Subscribed and sworn to before
me this 31st day of March, 2023

Notary Public: Rebecca Stockton
My Commission expires: 11/22/23

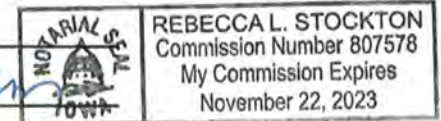

CERTIFICATE FOR PAYMENT

In accordance with Contract Documents, based on on-site observations and the data comprising application, the Architect certifies to the Owner that to the best of the Architect's knowledge, information and belief the Work has progressed as indicated, the quality of the Work is in accordance with the Contract Documents, and the Contractor is entitled to payment of the AMOUNT CERTIFIED.

AMOUNT CERTIFIED ----- \$ 29,742.10

(Attach explanation if amount certified differs from the amount applied for. Initial all figures on this application and on the Continuation Sheet that are changed to conform to the amount certified.)

ARCHITECT:

By: P. J. ... Date: 06/05/2023

This Certificate is not negotiable. The AMOUNT CERTIFIED is payable only to the Contractor named herein. Issuance, payment and acceptance of payment are without prejudice to any rights of the Owner of Contractor under this Contract.

Continuation Shet

ATTACHMENT TO PAY APPLICATION

Campground Shower House & Office Building

APPLICATION NUMBER: 8 - Retainage

APPLICATION DATE: 03/31/23

PERIOD TO: 03/31/23

ARCHITECT'S PROJECT NO: 3011C21

| A Item No. | B Description of Work | C Scheduled Value | D Work Completed | | F Materials Presently Stored (Not In D or E) | G | | H Balance To Finish (C - G) | I Retainage |
|------------------|--|-------------------------|---|-------------|---|--|------------|--------------------------------------|----------------|
| | | | From Previous Application (D + E) | This Period | | Total Completed And Stored To Date (D + E + F) | % (G/C) | | |
| 1 | General Conditions | 54,872.00 | 54,872.00 | | | 54,872.00 | 100% | | 2,743.60 |
| 2 | Site work and Excavation | 12,000.00 | 12,000.00 | | | 12,000.00 | 100% | | 600.00 |
| 3 | Concrete | 42,000.00 | 42,000.00 | | | 42,000.00 | 100% | | 2,100.00 |
| 4 | Masonry | 74,000.00 | 74,000.00 | | | 74,000.00 | 100% | | 3,700.00 |
| 5 | Structural Steel | 50,000.00 | 50,000.00 | | | 50,000.00 | 100% | | 2,500.00 |
| 6 | Lumber | 28,000.00 | 28,000.00 | | | 28,000.00 | 100% | | 1,400.00 |
| 7 | Insulation | 5,000.00 | 5,000.00 | | | 5,000.00 | 100% | | 250.00 |
| 8 | Metal Roof Panels and Trim | 50,000.00 | 50,000.00 | | | 50,000.00 | 100% | | 2,500.00 |
| 9 | Hollow Metal Doors | 9,000.00 | 9,000.00 | | | 9,000.00 | 100% | | 450.00 |
| 10 | Aluminum Framed Storefront | 39,000.00 | 39,000.00 | | | 39,000.00 | 100% | | 1,950.00 |
| 11 | Painting | 20,000.00 | 20,000.00 | | | 20,000.00 | 100% | | 1,000.00 |
| 12 | Toilet Accessories | 12,000.00 | 12,000.00 | | | 12,000.00 | 100% | | 600.00 |
| 13 | Plumbing | 83,000.00 | 83,000.00 | | | 83,000.00 | 100% | | 4,150.00 |
| 14 | HVAC | 49,000.00 | 49,000.00 | | | 49,000.00 | 100% | | 2,450.00 |
| 15 | Electrical | 46,000.00 | 46,000.00 | | | 46,000.00 | 100% | | 2,300.00 |
| 16 | CO #1 Vapor Barrier \$595 & Water Line \$15250 | 15,845.00 | 15,845.00 | | | 15,845.00 | 100% | | 792.25 |
| 17 | CO #2 Ice & Roof dam \$1750 & Root Ball \$1675 | 3,425.00 | 3,425.00 | | | 3,425.00 | 100% | | 171.25 |
| 18 | CO #3 Toilet Rough-In Adjustment | 1,700.00 | 1,700.00 | | | 1,700.00 | 100% | | 85.00 |
| Totals | | 594,842.00 | 594,842.00 | | | 594,842.00 | 100% | | 29,742.10 |

received
10-14-23 4pm

CITY OF OTTUMWA

Staff Summary

**** ACTION ITEM ****

Council Meeting of: Jun 20, 2023

Philip Rath

Prepared By

Administration

Department

Department Head

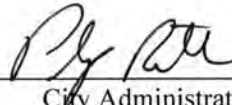

City Administrator Approval

AGENDA TITLE: Resolution No. 101-2023 - Approving a Three-Year School Resource Officer Agreement Between the City of Ottumwa and the Ottumwa Community School District

Public hearing required if this box is checked.

RECOMMENDATION: Pass and adopt Resolution 101-2023

DISCUSSION: The current Agreement with the Ottumwa School District related to School Resource Officers (SRO) expires on June 30, 2023. City staff negotiated with Ottumwa School District staff and reached a tentative agreement, attached for reference. The SRO program promotes cooperation and improved communication between the city and district. Further, the officers become part of the district safety team and assist with the development of safe and secure learning environments. The revised agreement identifies the expectations of the SROs and the participating entities as well as the cost sharing commitment.

Source of Funds:

Budgeted Item: Budget Amendment Needed:

RESOLUTION NO. 101-2023

**RESOLUTION APPROVING LEASE AGREEMENT BETWEEN
THE CITY OF OTTUMWA, IOWA AND THE OTTUMWA SCHOOL DISTRICT**

WHEREAS, the current agreement for School Resource Officers (SRO) between the City of Ottumwa, Iowa and the Ottumwa Community School District is set to expire on June 30, 2023; and

WHEREAS, the City and the District desire to continue the SRO program into the future; and

WHEREAS, a revised three-year agreement between the City of Ottumwa and the Ottumwa Community School District has been drafted to reflect this desire.

**NOW, THEREFORE, BE IT RESOLVED, BY THE CITY COUNCIL OF
THE CITY OF OTTUMWA, IOWA:**

That the proposed Agreement between the City of Ottumwa and the Ottumwa Community School District is hereby approved; and

That the Mayor and the City Clerk of the city of Ottumwa, Iowa, are hereby authorized and directed to execute said renewal on behalf of the City.

APPROVED, PASSED AND ADOPTED, this 20th day of June, 2023.

CITY OF OTTUMWA, IOWA

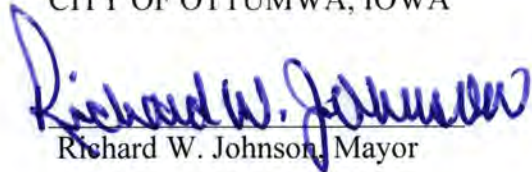
Richard W. Johnson, Mayor

ATTEST:



Christina Reinhard, City Clerk

**SCHOOL RESOURCE OFFICER AGREEMENT
FISCAL YEAR 2024-2026**

THIS AGREEMENT is made and entered into this 20 day of June 2023, by and between the Ottumwa Community School District, hereinafter referred to as "District" and the City of Ottumwa, Iowa, hereinafter referred to as "City."

WITNESSETH:

WHEREAS, The District is a school corporation located in Ottumwa, Iowa, charged with the responsibility of educating students within its boundaries and providing those students with a safe, secure environment in which to learn; and

WHEREAS, the City is a municipal corporation which has a part of its governmental duties the enforcement of laws and the protection of all of its citizenry; and

WHEREAS, to accomplish that purpose the City maintains and operates a police force; and

WHEREAS, in order to provide greater security for its students and a more secure learning environment, District is desirous of using the services of the City Police Department more actively and effectively within its schools; and

WHEREAS, both the City and the District are desirous of having law enforcement officers specifically designated and trained to work in the schools and with students; and

WHEREAS, the City is desirous of providing such officer(s); and

WHEREAS, the District is desirous of reimbursing the City for the costs of said officer(s).

NOW, THEREFORE, IT IS HEREBY AGREED by and between the District and the City as follows, to-wit:

I. SCHOOL RESOURCE OFFICER PROGRAM.

- (A) The City agrees to create a position or positions within its Police Department known as School Resource Officer, hereinafter referred to as "Officer," and to fill and maintain such position with a peace officer certified as such by the State of Iowa following the guidelines identified per this agreement.

- (B) The Officer is not, under any circumstances, an employee of, agent for, or contractor for the District. The Officer is solely employed by the City and is subject only to the City's direction and control. Under no circumstances is the District responsible for the officer's actions, compensation, or direction, those being the sole responsibility of the City.

II. APPOINTMENT AND ASSIGNMENT.

- (A) **Position of SRO.** The City agrees to provide a job description for said Officer which will accomplish the joint aims of the parties announced herein. The City will request input from the District in creating and/ or updating said job description. District shall provide such input upon request and may also provide unsolicited input to the City regarding the needs of the position as desired.
- (B) **Applications and Selection Process.** The City shall be responsible for the initial receipt of applications interested in the SRO assignment. To the extent permitted by any Collective Bargaining Agreement, the District will make suggestions as to the person(s) selected to fill the position(s) by the City and the District's suggestions will be used by the City to make a joint and collectively agreed upon hiring decision.
- (C) **Appointment of SRO.** The Chief of Police of the City is hereby authorized to appoint the SRO. The SRO is an employee of the City of Ottumwa Police Department, and pursuant to any limits imposed by a Collective Bargaining Agreement, the position shall be filled by a person having training in the area of juvenile law, DARE, youth crime, and gangs. The individual chosen to fill the position shall have the necessary temperament to deal with juvenile students and shall be able to establish a rapport with them and earn their trust and respect.
- (D) **Assignment of SRO.** The Officers shall be stationed with a work space in a securable location within one of the school buildings within the District. City shall sign off on any work space to ensure it meets the need of the SRO. SRO's shall be directly involved in day-to-day operations as they pertain to the safety, supervision, and security of students. If necessary and appropriate, the Officer may work in other school buildings and at other school sites on a temporary basis as mutually agreed upon by the District and the Police Chief (or their designee). The Officer shall further work at extra-curricular activities, such as football and basketball games, plays, band concerts, orchestra concerts, dances, pep rallies, and other after-school activities where students are present. The school district agrees to pay the officer's overtime rate when he or she is required to work at extra-curricular activities. The District will have the right to request of the City the scheduling and locating of the Officer and specific times and locations and, upon receipt of said request, the City shall comply with the same within the guidelines of any Collective Bargaining Agreement. The District will make suggestions to the City as to the hours of the Officer's work to reduce overtime and the City will comply within the guidelines of any Collective Bargaining Agreement.

III. TRAINING, DISCIPLINE AND EQUIPMENT.

- (A) **Training.** Training of the SRO shall be coordinated through the City of Ottumwa Police Department under the authority of the Chief of Police. If there are specific trainings that the District would like the SRO to attend, said training and its expense may be mutually agreed upon and costs will be paid by the District.
- (B) **Performance and Discipline.** The District will have advisory input into the SRO's annual performance evaluation. The City of Ottumwa Police Department shall address any performance concerns. The District shall report performance issues directly to the Chief of Police.
- (C) **Uniforms and Equipment.** All equipment and uniforms shall be the responsibility of the City of Ottumwa and be in accordance with Department rules and regulations for police officers. The SRO will be equipped with the standard Ottumwa Police Department personal carry audio/video recording device (body cam), and will follow Police Department guidelines as to when this unit will be activated.
- (D) **SRO Duties and Schedule.**
 - 1. The SRO duties shall include:
 - (a) Proactively communicating with students and staff while being a highly visible presence within the school.
 - (b) Being an active liaison between Ottumwa Police Department and District Administration. This includes sharing pertinent information involving District students and/or staff in a proactive manner, so long as such information sharing doesn't jeopardize ongoing investigations, or violate Police Department policies, or Iowa State Statutes.
 - (c) Being a member of the School District's Safe Schools Interagency Team.
 - (d) Draft weekly or monthly reports of their activities as requested by the District and/or City.
 - (e) Supervision of students before school, during passing time/between classes, at lunch time, and after school, including any extracurricular activities and events as assigned.
 - 2. SRO Role:
 - (a) The mission of the SRO program is to improve school safety and the educational environment at the school(s).
 - (b) The SRO is responsible for dealing with criminal law issues, not to enforce school discipline or punish students. The SRO will refer students to the school administration for school disciplinary issues observed by the SRO.
 - (c) The SRO shall meet with school district administrators, staff, and security staff on a regular and ongoing basis (at least weekly) to discuss issues of school safety.

- (d) The SRO shall maintain activity records and submit summaries of these reports to the school administration and the police department, as well as providing a copy of reports on incidents when they happen.
- (e) Absent a real and immediate threat to student, school staff or school safety, and absent the situations described herein where formal law enforcement intervention is deemed appropriate, school administrators shall have the final authority in the building.
- (f) Absent a real and immediate threat to student, school staff or public safety, incidents involving public order offenses, including: disturbance/disruption of schools or public assembly; profanity; and fighting which does not involve physical injury or weapon, shall be considered school discipline issues to be handled by school officials, rather than criminal law issues warranting formal law enforcement intervention (e.g., issuance of criminal charges, municipal or traffic citations, referral for delinquency petitions, etc., not inclusive).
- (g) All searches in school or on school property will be decided on, and conducted by school officials. The SRO can stand by or assist after the school official has begun the search when requested.
- (h) Students shall not be taken into custody by the SRO at school, except where a child poses a real and immediate threat to student, school staff, public safety, or pursuant to a warrant. School administrators shall be consulted prior to a student being taken into custody where practicable. The student's parent or guardian shall be notified of a child being taken into custody as soon as practicable.
- (i) The school district designates the SRO a "school official" as provided in the Federal Educational Rights and Privacy Act (FERPA) 20 USC 1232G. The SRO may be provided access to student records as needed by the SRO to perform SRO duties, or in the event of an emergency situation threatening the health or safety of a student or another individual. The SRO may only re-disclose this information consistent with FERPA and Iowa law.
- (j) Records created and maintained by the SRO for the purpose of ensuring safety and security in the school(s), or for enforcement of the law-even when such records may serve a dual purpose of enforcing school rules, are not subject to the same regulations such as those under FERPA and Iowa law, and likely are not student records, but are subject to the same status as police department records.

IV. SRO COMPENSATION, BENEFITS AND PERSONNEL SUPERVISION.

- (A) **Payroll.** The City shall be responsible for all payroll-associated functions, including providing compensation to the SRO in accordance with City policies.
- (B) **Worker's Compensation.** The City shall be responsible for providing any other benefits to the assigned SRO, and are entitled under any applicable state or federal law, including but not limited to worker's compensation and unemployment

compensation. If the SRO is injured, the school and police department will negotiate if the SRO will continue at the school in a light duty status or be replaced.

- (C) **Personnel records.** The City shall be responsible for maintaining the SRO's employee personnel file records.

V. COST OF PROGRAM.

- (A) **Wages and Benefits:** The Officer shall receive all of his or her compensation from the City as an employee thereof, and all benefits afforded a City employee shall be afforded to the Officer. The Officer shall not be entitled to receive any benefits which the District affords its employees. The Officer is not an employee of the District for purposes of Iowa Workers Compensation Law or unemployment compensation benefits but is, for such purposes and all others, an employee of the City.
- (B) **Payment:** That as consideration for the services and acts to be rendered by the City hereunder, the District shall pay to the City a sum described in Appendix A.

VI. LIABILITY; INSURANCE.

- (A) The City agrees that it will indemnify and hold harmless the District for any liability of any nature whatsoever in connection with any actions of the employee of any nature whatsoever. City further agrees to cause the District to be named as an insured on the City's current policy of liability insurance affording coverage from liability by reason of the officer's acts and that said policy shall have at least a \$1,000,000 limit of liability.
- (B) City further agrees to indemnify and hold harmless the District from any claims of any nature whatsoever which said Officer may make against the District in connection with said Officer's performance of the duties assigned to him in connection with this Agreement.

VII. PRIOR AGREEMENT TERMINATION. Any other Agreement regarding the SRO is hereby terminated and superseded by the terms of this Agreement.

VIII. AMENDMENTS. This agreement may be amended only upon the mutual written agreement executed by both parties.

IX. TERM. This agreement shall be for three fiscal years, 2024-2026, commencing July 1, 2023 and ending June 30, 2026. It is provided, however, that in the event that either party is desirous for any reason to terminate this agreement, said party may do so upon 30 days written notice to the other party.

X. OPTION TO TERMINATE.

Either party may terminate this Agreement upon thirty (30) days' written notice to the other party of their intent to do so. Provided, however, that the Chief of Police of the City shall have the authority to immediately suspend the provisions of this Agreement shall it be deemed necessary in the interest of public safety.

XI. NOTICE. Any notice required by this Agreement shall be sent to the respective parties at the addresses set forth below. Notice shall be deemed given upon depositing said Notice in a U.S. postal depository, with proper postage affixed thereto, and address as follows:

TO THE DISTRICT: Board of Education
Ottumwa Community School District
1112 N. Van Buren
Ottumwa, IA 52501

NOTICE TO CITY: City Administrator
Ottumwa City Hall
105 E. Third Street
Ottumwa, IA 52501

OTTUMWA COMMUNITY SCHOOL DISTRICT

BY: Michael B. Kow
President, Board of Directors

ATTEST: [Signature]
Secretary, Board of Directors

CITY OF OTTUMWA, IOWA

BY: Richard W. Johnson
Richard W. Johnson
Mayor

ATTEST: Chris Reinhard
Chris Reinhard
City Clerk



APPENDIX A

SCHOOL RESOURCE OFFICER AGREEMENT
 OTTUMWA COMMUNITY SCHOOL DISTRICT
 and
 CITY OF OTTUMWA

Per the Agreement, SRO’s shall be stationed at selected school district facilities for 8 hours daily during regularly scheduled school days for a total of 180 days. The base annual cost for providing this service (exclusive of overtime costs) shall be fifty percent (50%) of the Actual Cost of the officer(s) as identified in the table below.

The calculation used in determining the actual base SRO costs for the year shall include the annual salary as well as the City's contributions for pension, health insurance, life insurance, workman's compensation, and Medicare. The table below illustrates these costs for the 2023-24 fiscal year. In subsequent years the City will update the table to reflect actual costs.

Calculated Actual SRO Costs - July 1, 2023 through June 30, 2024

| | <u>SRO #1</u> | <u>SRO #2</u> | <u>SRO #3</u> |
|-------------------------------|------------------|------------------|------------------|
| Salary: | \$80,611 | \$79,716 | \$80,983 |
| Pension: | 18,525 | 18,525 | 18,525 |
| Medicare: | 1,169 | 1,156 | 1,174 |
| Life Insurance: | 219 | 219 | 219 |
| Work Comp: | 750 | 750 | 750 |
| Health Insurance: | 29,692 | 29,692 | 18,378 |
| Salary & Benefits: | \$130,966 | \$130,058 | \$120,029 |

Estimated Contractual Costs by Year - July 1, 2023 through June 30, 2026

| | <u>07/01/23-06/30/24</u> | <u>07/01/24-06/30/25</u> | <u>07/01/25-06/30/26</u> |
|---------------------------|--------------------------|--------------------------|--------------------------|
| SRO #1: | \$130,966 | \$138,824 | \$147,154 |
| SRO #2: | 130,058 | 137,862 | 146,134 |
| SRO #3: | 120,029 | 127,230 | 134,864 |
| SRO Cost (FY 24): | \$381,053 | \$403,916 | \$428,152 |
| OCSD Program Cost: | \$190,526.50 | \$201,958 | \$214,076 |

received
10-15-23 1030

CITY OF OTTUMWA

Staff Summary

**** ACTION ITEM ****

Council Meeting of: June 20, 2023

Larry Seals

Prepared By

Larry Seals

Department Head

Engineering Department
Department

[Signature]

City Administrator Approval

AGENDA TITLE: Resolution #102-2023. Approve Change Order #2 for the Blake's Branch Sewer Separation Phase 8, Division 1, East of Iowa Avenue Project.

****Public hearing required if this box is checked. ****

****The Proof of Publication for each Public Hearing must be attached to this Staff Summary. If the Proof of Publication is not attached, the item will not be placed on the agenda. ****

RECOMMENDATION: Pass and adopt Resolution #102-2023.

DISCUSSION: Change Order #2 will provide compensation to the Contractor for relocating the existing water main at the intersection of 4th Street and Van Buren Avenue and the intersection of Foster Avenue and Alley.

Change Order #2 increases the contract amount by \$13,060.07. The new contract sum is \$3,162,815.07.

| | |
|---------------|------------------|
| Contract: | \$3,143,755.00 |
| CO #1: | 6,000.00 |
| CO #2: | <u>13,060.07</u> |
| New Contract: | \$3,162,815.07 |

Budgeted amount: \$3,000,000.00

Current construction estimate is \$2,650,000.00

Source of Funds: CIP \$2,000,000 Balance RU Budgeted Item: Yes

Budget Amendment Needed: No

RESOLUTION #102-2023

A RESOLUTION APPROVING CHANGE ORDER #2
FOR THE BLAKE'S BRANCH SEWER SEPARATION PHASE 8, DIVISION 1, EAST OF IOWA
AVENUE PROJECT

WHEREAS, The City Council of the City of Ottumwa, Iowa entered into a contract with Langman Construction, Inc. of Rock Island, Illinois on March 15, 2022 for the above referenced project; and

WHEREAS, Change Order #2 increases the contract amount by \$13,060.07 resulting in a new contract sum of \$3,162,815.07;

NOW, THEREFORE, BE IT RESOLVED, BY THE CITY COUNCIL OF THE CITY OF OTTUMWA, IOWA THAT: The above mentioned change order for this project is hereby approved.

APPROVED, PASSED, AND ADOPTED, this 20th day of June, 2023.

CITY OF OTTUMWA, IOWA

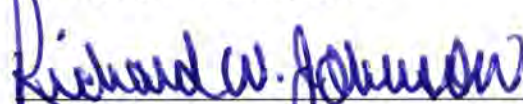
Richard W. Johnson, Mayor

ATTEST:

Christina Reinhard, City Clerk



May 30, 2023

CHANGE ORDER NO. 2

OTTUMWA, IOWA
BLAKE'S BRANCH SEWER SEPARATION PHASE 8
EAST OF IOWA AVENUE SEWER SEPARATION

This change order is to provide compensation to the Contractor for relocating the existing water main at the intersection of 4th Street and Van Buren Avenue and the intersection of Foster Avenue and Alley.

Item #1 - During construction of the new storm sewer at the intersection of 4th Street and Van Burren Avenue, the existing 6" water main was discovered to in conflict with the new storm pipe. The location of the new storm sewer was located to connect to the existing storm pipe and above the existing sanitary sewer. The existing water main pipe required relocation above the new storm sewer pipe.

Item #2 – During construction of the new storm sewer at the intersection of Foster Avenue and the Alley, the existing water main was discovered to in conflict with the new storm pipe. The location of the new storm sewer was located to be below the new water main and above the existing sanitary sewer. The existing water main pipe was lower than anticipated and required relocation above the new storm sewer pipe.

This change order is to provide compensation to the contractor for relocating the water main at the intersection of 4th Street and Van Buren Avenue and the intersection of Foster Avenue and Alley.

The cost adjustment for the added works is based on a lump sum price negotiated with the Contractor as follows:

Item #1 – Compensate the Contractor for providing all labor, materials, and equipment necessary to excavate, furnish and install 6" pipe, fittings, thrust blocks, pipe repair couplings, furnish, place and compact bedding and backfill material, tracer system, disinfect pipe, remove old pipe and additional associated miscellaneous work to relocate water main at the intersection of 4th Street and Van Buren Avenue.....\$4,246.58

Item #2 – Compensate the Contractor for providing all labor, materials, and equipment necessary to excavate, furnish and install 6” pipe, fittings, thrust blocks, pipe repair couplings, furnish, place and compact bedding and backfill material, tracer system, disinfect pipe, remove old pipe, relocate water service and additional associated miscellaneous work to relocate water main at the intersection of Foster Avenue and Alley.....\$8,813.49

Change Order No. 2 increases the contract amount by \$13,060.07.

LANGMAN CONSTRUCTION, INC.
By [Signature]

Title: Project Manager
Date 6/5/2023

VEENSTRA & KIMM, INC.
By [Signature]

Title: Project Engineer
Date 6/6/2023

CITY OF OTTUMWA, IOWA
By [Signature]

Title: Director of Public Works
Date 6/13/2023

ATTEST:
By [Signature]

Title: Admin Asst.
Date 6/6/23

received

10-15-23 1030

CITY OF OTTUMWA

Staff Summary

**** ACTION ITEM ****

Council Meeting of: June 20, 2023

Engineering Department
Department

Larry Seals
Prepared By
Larry Seals
Department Head

[Signature]
City Administrator Approval

AGENDA TITLE: Resolution #103-2023. Approving the IDOT STBG/SWAP Application for the North Court Reconstruction Project and authorizing the Mayor to sign the application.

RECOMMENDATION: Pass and adopt Resolution #103-2023.

DISCUSSION: This IDOT STBG/SWAP Application is for funding for full-depth, full-width reconstruction of North Court Street from Park Avenue to 100 LF North of Vanness Avenue. This project includes replacement of sanitary sewer and installation of a separate storm system.

Two new features include the installation of a bus student drop off lane and an 8' multi-use trail as detailed in the City's Master Trail System Plan.

Federal grant funds are available annually to the City of Ottumwa and are administered by Area 15 Regional Planning Affiliation members for use on roadway improvement projects. Funding for projects through this program require a 20% local match, 80/20.

The project will be programmed for a 2027 construction season. Design would start 2024/2025. Local match will be allocated from future funds which could include any combination of CIP Bond issues, RU, Lost and Sewer Revenue.

| | | |
|---|-------------|-----------|
| | STBG | Local |
| This project is estimated at \$3,204,950. | \$2,563,960 | \$640,990 |

Funding: Future Allocation.

\$2,563,960 STBG/SWAP Funding

Source of Funds: STBG/SWAP +Local Budgeted Item: No: future obligation Budget Amendment Needed: No

RESOLUTION #103-2023

A RESOLUTION APPROVING THE IDOT STBG/SWAP
APPLICATION AND AUTHORIZING THE MAYOR TO SIGN THE APPLICATION

WHEREAS, The City Council of the City of Ottumwa, Iowa, is legible to make an application for the Iowa Department of Transportation STBG/SWAP Program; and,

WHEREAS, The STBG/SWAP Application will fund up to 80% of a project; and,

WHEREAS, The City of Ottumwa has authorized matching funds through the Capital Improvements Program (CIP).

NOW, THEREFORE, BE IT RESOLVED, BY THE CITY COUNCIL OF THE CITY OF OTTUMWA, IOWA THAT: The IDOT STBG/SWAP Application is hereby approved and the Mayor is authorized to sign the Application.

APPROVED, PASSED, AND ADOPTED, this 20th day of June, 2023.

CITY OF OTTUMWA, IOWA

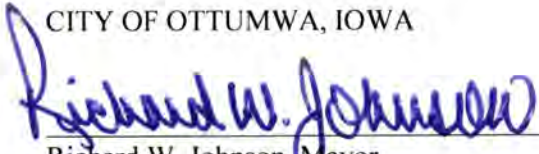
Richard W. Johnson, Mayor

ATTEST:

Christina Reinhard, City Clerk

**RPA 15 STBG/SWAP APPLICATION
APPLICATION FORM**

GENERAL INFORMATION

Name of Applicant City of Ottumwa
Name of Sponsor _____
Contact Person Larry Seals
Mailing Address 105 E. 3rd St. Ottumwa, IA 52501
Phone Number 641-683-0680

PROJECT INFORMATION

Project Name (route/facility) North Court Street Length (miles) .38

Category Construction Reconstruction Transit Planning

Project Cost

| Total Cost | STBG/SWAP Funds | Sub-Allocation | Local Funds | Other (source) () |
|-------------|-----------------|----------------|-------------|--------------------|
| \$3,204,950 | \$2,563,960 | \$ | \$640,990 | \$ |

Programming Year FY24 FY25 FY26 FY27

APPLICATION CHECKLIST

The following items must be included with the application:

- Project Description
- Project Location Map
- Photographs of project area and conditions
- Response to Each Rating Criterion
- Detailed Cost Estimate
- Project Timeline
- Resolution from Sponsor

Richard W. Johnson
Signature of Chief Officer of Sponsoring Organization
Richard W. Johnson

Mayor
Title

6.20.2023
Date

| TRAFFIC VOLUME | | | Maximum 20 Points: | |
|------------------------------|--------------------------|--|--------------------------------|--------------------|
| Annual Average Daily Traffic | Rural Project | Points (circle) | Urban Project | Points (circle) |
| Actual AADT: | 2000+ | 10 | 10,000+ | 10 |
| | 1000+ | 9 | 5,000+ | 9 |
| Source: | 500+ | 8 | 2,000+ | 8 |
| | 100+ | 6 | 1,000 | 6 |
| | 50+ | 5 | 500+ | 5 |
| Average AADT: | 6200 DOT interactive map | Allow 1 pt. For each 10% above average | Percent Above Average _____ | Points 9 |

| ROUTE CONTINUITY | | Maximum 10 Points: | |
|--|---------------|--------------------|-------------|
| Applicant must justify continuity in the project description | Regional | | 10 (Points) |
| | County/County | | 8 |
| | City/County | | 8 |
| | Intra County | | 5 |
| | Intra City | | 5 |

| TRUCK TRAFFIC | | Maximum 10 Points: | |
|--|---------------|--------------------|-----------------|
| 1 Point for each Rural % of truck traffic | _____ % Rural | | _____ Points |
| 2 Points for each Urban % of truck traffic | _____ % Urban | | 4 Points |
| Source of truck traffic estimate: City of Ottumwa local count | | | |

| FEDERAL FUNCTIONAL CLASS | | Maximum 20 Points: | |
|--------------------------------|--------|--------------------|-----------|
| Rural and Small Municipalities | Points | Urban | Points |
| Principal Arterial | 20 | Principal Arterial | 20 |
| Minor Arterial | 16 | Minor Arterial | 16 |
| Major Collector | 12 | Collector | 12 |
| Minor Collector | 8 | | |

| FACILITY CONDITION | | Maximum 20 Points: | |
|--------------------|--|--------------------|-------------|
| Poor | | | 20 (Points) |
| Below Average | | | 16 |
| Average | | | 12 |
| Above Average | | | 8 |
| Excellent | | | 4 |

| LONG RANGE PLAN GOALS | | Maximum 20 Points: | |
|---|----------|--------------------|---|
| Maintains or improves the condition of the facility | Yes / No | 4 (Points) | 4 |
| Improves safety, especially in areas with history of crashes | Yes / No | 4 | 4 |
| Reduces vehicle, freight, transit, rail, bicycle and pedestrian conflicts | Yes / No | 2 | 2 |
| Improve travel times or level of service | Yes / No | 2 | 2 |
| Improve connectivity between cities or regions | Yes / No | 2 | 0 |
| Benefits more than one agency | Yes / No | 2 | 2 |
| Supports job creation or retention (provides access to) | Yes / No | 2 | 0 |
| Promotes transit, bicycling and/or walking as transportation | Yes / No | 2 | 2 |

| TOTAL SCORE | | Maximum 100 Points | |
|-------------|---------------------------|--------------------|-----------|
| | Applicant | \$ | 66 |
| | RPC Recommendation | \$ | |
| | TOTAL | \$ | |
| | Recommended Funding Level | \$ | |

PROJECT DESCRIPTION

Originally constructed as Highway 63, North Court Street is a major arterial two lane roadway that is the backbone for various arterial and collector streets (see attached map) that serves the north side residential area to the Downtown Commercial Business District. This section is 41' with parallel parking on both sides. It houses Horace Mann Elementary, as well as being in close proximity to James Elementary School and Indian Hills Community College.

This project will include the complete reconstruction of North Court Street from Park Avenue to Vogel Avenue. Sidewalk improvements will be made where needed, as well as constructing an 8' multiuse trail on one side as part of our "safe routes to school" program, as well as being part of the Ottumwa Trails long range plan to connect the north side to down town. The project will also include utility improvements including storm sewer installation and sanitary sewer repairs as needed. We will also be adding a 12' bus lane for pick up and drop off along the front of Horace Mann School.

The Iowa Department of Transportation has traffic counts for this portion of North Court Street. The 2018 AADT count was 2,940 vehicles on this portion of North Court Street.

The reconstruction of North Court Street will help improve daily traffic flow as well as aid the accessibility of the downtown Business District to the surrounding residential community by both vehicular and pedestrian traffic.



Proposed Funding including Engineering costs:

Federal (STP)
\$2,563,960

Local
\$640,990

Total
\$3,204,950

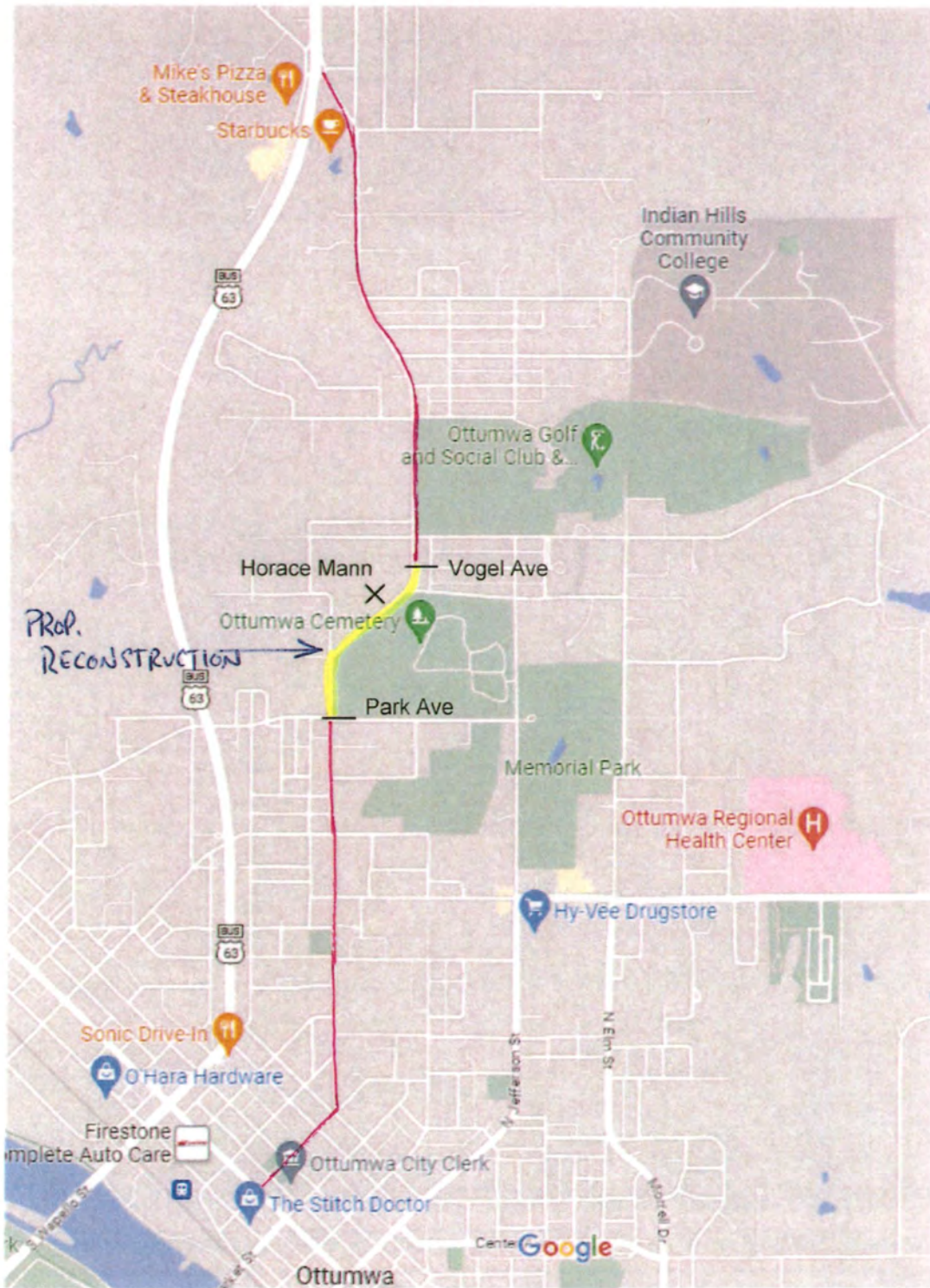



| | | | | | |
|--|--|------------------------------|-------------------------------|---|----------------|
|  | ENGINEERING DEPARTMENT 105 E. 3rd St. Ottumwa, IA 52501 ph. 641-683-0680 fax. 641-683-0892 | Scale: 1"=200' Date: 2023 | Drawn by: OED Approved by: | PROJECT NAME North Court Reconstruction & Sewer Separation | SHEET NO. 1 |
| | | | | | |

Photographs



North Court: This form of deterioration can be found throughout the project.



Failing gutterline. Pavement deterioration.



Existing Street Condition:



Existing pavement condition. Chip seal was added in the late 90's as an attempt to preserve the asphalt.



Gutterline failure, existing pavement condition.



Multiple patching attempts including HMA, and PCC. Failing Gutterline.

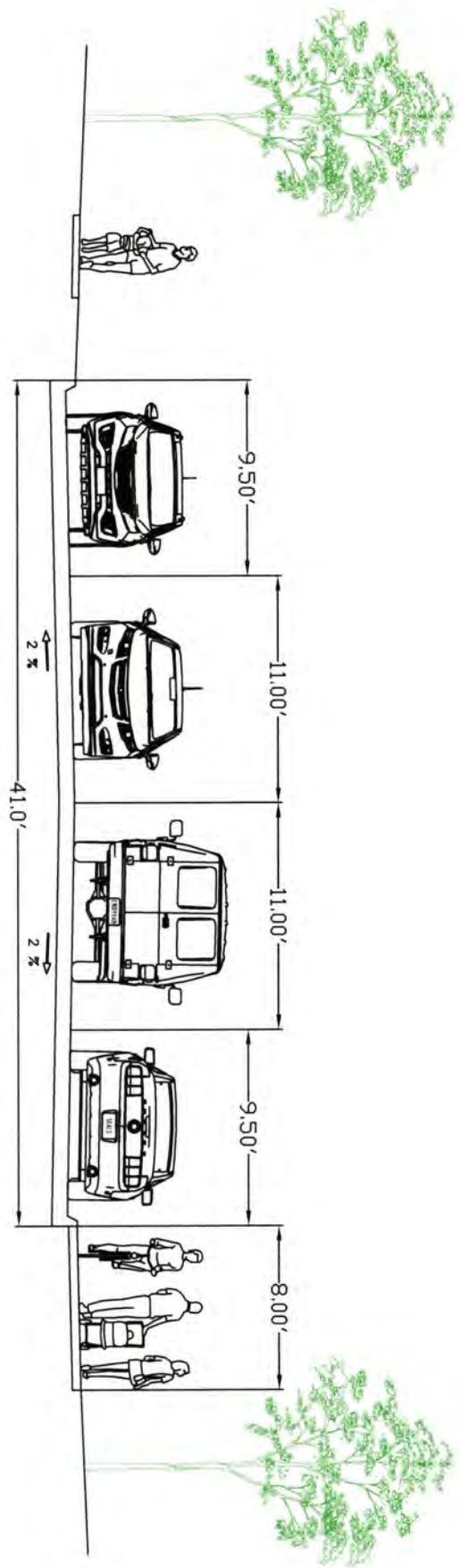
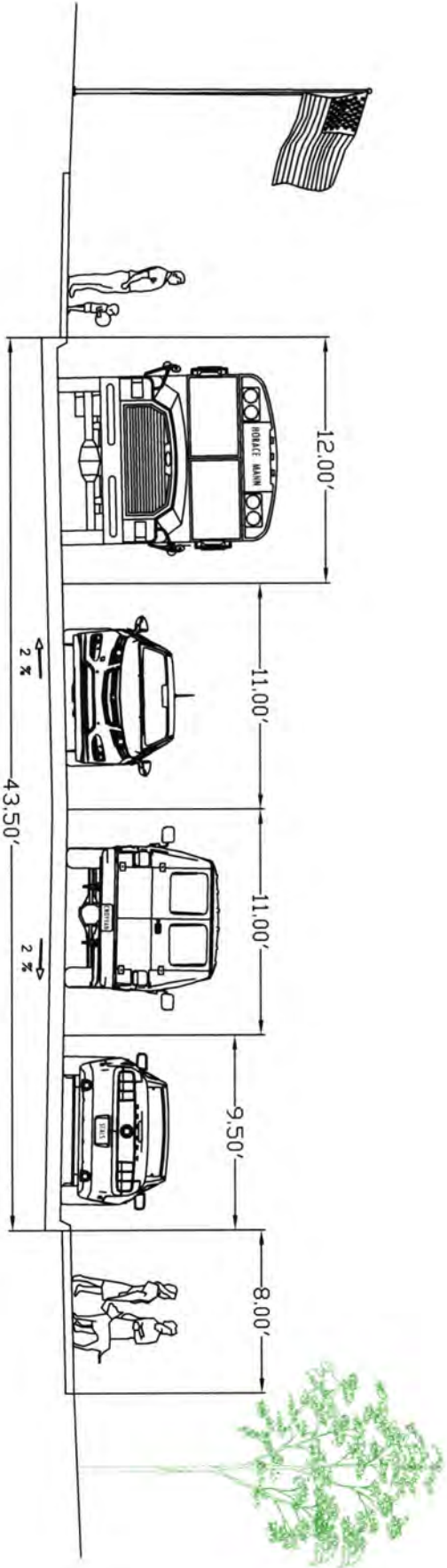

North Court Reconstruction
 Engineers Estimate
 3-27-2023 SM

North Court Reconstruction- Park to Vogel
 North Court Sewer Separation-Park to Oakwood

| Item No | Item Description | Unit | Quantity | Price | Total |
|---------|--|------|----------|-----------------|-----------------------|
| 1 | TOPSOIL, FURNISH, HAUL AND SPREAD | CY | 300 | \$50.00 | \$15,000.00 |
| 2 | EXCAVATION, CLASS 10 | CY | 1825 | \$15.00 | \$27,375.00 |
| 3 | SUBGRADE PREP | SY | 12015 | \$6.00 | \$72,090.00 |
| 4 | MODIFIED SUBBASE | SY | 12015 | \$12.50 | \$150,187.50 |
| 5 | STORM SEWER MANHOLE, SW-401 | EA | 3 | \$7,500.00 | \$22,500.00 |
| 6 | STORM SEWER, TRENCHED, 15" RCP | LF | 2090 | \$150.00 | \$313,500.00 |
| 7 | APRON, RCP, 15" W/FOOTING | EA | 3 | \$3,000.00 | \$9,000.00 |
| 8 | EROSION STONE, CLASS D | TN | 40 | \$70.00 | \$2,800.00 |
| 9 | SUBDRAIN, STD. PERFORATED 4" | LF | 5315 | \$10.00 | \$53,150.00 |
| 10 | SUBDRAIN OUTLET, (4040.233) | EA | 13 | \$300.00 | \$3,900.00 |
| 11 | SANITARY SEWER MANHOLE, SW-301 | EA | 15 | \$2,500.00 | \$37,500.00 |
| 12 | SANITARY SEWER 18" | LF | 2230 | \$105.00 | \$234,150.00 |
| 13 | SINGLE GRATE INTAKE, SW-501 | EA | 9 | \$5,500.00 | \$49,500.00 |
| 14 | SINGLE GRATE INTAKE WITH MANHOLE, SW-503 | EA | 12 | \$7,500.00 | \$90,000.00 |
| 15 | REMOVE MANHOLE OR INTAKE | EA | 32 | \$1,500.00 | \$48,000.00 |
| 16 | REMOVE SAN OR STORM PIPE <36" | LF | 2616 | \$45.00 | \$117,720.00 |
| 17 | WATER SERVICE STUB, 3/4" | EA | 11 | \$1,800.00 | \$19,800.00 |
| 18 | WATER SERVICE STUB, 2" | EA | 2 | \$2,250.00 | \$4,500.00 |
| 19 | PCC PAVEMENT, CL C, CL 3, 8" | SY | 11255 | \$80.00 | \$900,400.00 |
| 20 | REMOVAL OF PAVED DRIVEWAY | SY | 330 | \$15.00 | \$4,950.00 |
| 21 | REMOVAL OF SIDEWALK | SY | 1960 | \$15.00 | \$29,400.00 |
| 22 | SIDEWALK, PCC 6" | SY | 1015 | \$85.00 | \$86,275.00 |
| 23 | DRIVEWAY, PCC 6" | SY | 345 | \$85.00 | \$29,325.00 |
| 24 | DETECTABLE WARNING | SF | 250 | \$60.00 | \$15,000.00 |
| 25 | MULTIUSE TRAIL, 8' WIDE, 6" THICK | SY | 1890 | \$115.00 | \$217,350.00 |
| 26 | CONCRETE MEDIAN | SY | 11 | \$300.00 | \$3,300.00 |
| 27 | REMOVAL OF PAVEMENT | SY | 11115 | \$15.00 | \$166,725.00 |
| 28 | PAINTED PAVEMENT MARKINGS DURABLE | STA | 6 | \$300.00 | \$1,800.00 |
| 29 | PAINTED PAVEMENT SYMBOLS DURABLE | EA | 5 | \$750.00 | \$3,750.00 |
| 30 | TRAFFIC CONTROL | LS | 1 | \$10,000.00 | \$10,000.00 |
| 31 | SEEDING, FERTILIZING, & MULCHING | LS | 1 | \$6,500.00 | \$6,500.00 |
| 32 | EROSION CONTROL | LF | 300 | \$7.50 | \$2,250.00 |
| 33 | EROSION CONTROL REMOVAL | LF | 300 | \$2.50 | \$750.00 |
| 34 | MOBILIZATION | LS | 1 | \$25,000.00 | \$25,000.00 |
| 35 | TRENCH COMPACTION TESTING | LS | 1 | \$6,000.00 | \$6,000.00 |
| 36 | CONSTRUCTION SURVEY | LS | 1 | \$5,000.00 | \$5,000.00 |
| 37 | CONCRETE WASHOUT | LS | 1 | \$2,500.00 | \$2,500.00 |
| | | | | | |
| | | | | Total | \$2,786,947.50 |
| | | | | 5% cont. | \$139,300.00 |
| | | | | 10% eng. | \$278,700.00 |
| | | | | | |
| | | | | | \$3,204,947.50 |

PROJECT RATING CRITERIA

Traffic Volume

The Iowa Department of Transportation has three traffic counts in this corridor of North Court. Using the traffic counts from the Annual Average Daily Traffic (AADT) map shows an average of 6200 vehicles per day. *(Rating 9)*

Route Continuity

This route directly connects the north side to the Down town business district. This project is located within the City Limits of Ottumwa. *(Rating 5)*

Truck Traffic

The Ottumwa Engineering Department performed actual truck traffic count. Based on those counts, 2% of the traffic on North Court Street is truck traffic. *(Rating 4)*

Federal Functional Class

This Street is classified as a Minor Arterial. *(Rating 16)*

Facility Condition

(See Pictures). The street in this project area is in below average condition and shows many forms of deterioration. The street has been patched multiple times using different patching methods, (HMA and PCC) to try and extend the pavement life. A chip seal was applied in the late 90's but has long since reached its finish line. Many of the pavement failures can be attributed to a faulty water main. Ottumwa Water and Hydro has constructed a new water main along this entire corridor three years ago.

The extent of the pavement failure indicates that Full Width, Full Depth reconstruction with roadbed preparation will be required. *(Rating 18)*

Safety and Long Range Plan Goals

In order to improve safety for pick up and drop off of Horace Mann Elementary students, we will be adding a bus lane along the north side of the street in front of the school. This will improve traffic flows during morning and afternoon commutes, as well as safety for the children getting on and off of the buses.

An 8' multiuse trail is planned along the south side of the corridor as part of the "Safe Routes to School" program and also as part of the Ottumwa Trails long range plan to connect the north side to the down town business district.

The street will be built using current design standards, and sidewalks/trails will be built to current ADA guidelines. *(Rating 16)*

Total Score: 66

received
6/15/23 11AM

CITY OF OTTUMWA
Staff Summary

**** ACTION ITEM ****

Council Meeting of: Jun 20, 2023

Finance
Department

Waseem Nisar
Prepared By
Waseem Nisar
Department Head



City Administrator Approval

AGENDA TITLE: Resolution 104-2023 - a Resolution Awarding a Five-Year Agreement to Bergan KDV, Ltd. for Audit Services

Public hearing required if this box is checked.

RECOMMENDATION: Pass and adopt resolution # 104-2023

DISCUSSION: City of Ottumwa issued a RFP to perform its annual financial audit. The RFP was closed at 3:00 PM on June 12, 2023.

We received only one proposal for this purpose; the proposal is from Bergan KDV Ltd. in the amounts \$42,900, \$45,000, \$47,500, \$50,000, and \$52,500 respectively for five year periods.
A copy of the proposal is attached.

Source of Funds:

Budgeted Item: Budget Amendment Needed:

RESOLUTION NO. 104-2023

**RESOLUTION AWARDING A FIVE-YEAR AGREEMENT TO
BERGAN KDV, LTD. FOR AUDIT SERVICES**

WHEREAS, the City of Ottumwa, Iowa did advertise and accept proposals for the above referenced service; and

WHEREAS, a proposal was received from Bergan KDV, Ltd. to provide the stated service.

**NOW, THEREFORE, BE IT RESOLVED, BY THE CITY COUNCIL OF
THE CITY OF OTTUMWA, IOWA:**

The award of agreement for the above referenced service is made and an engagement letter between the City of Ottumwa and Bergan KDV, Ltd. will be drafted and presented before the City Council of the City Ottumwa in the near future.

APPROVED, PASSED AND ADOPTED, this 20th day of June, 2023.

CITY OF OTTUMWA, IOWA

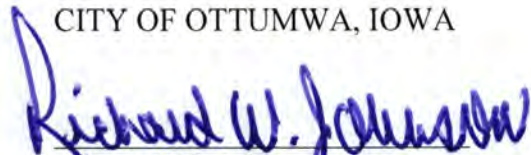
Richard W. Johnson, Mayor

ATTEST:



Christina Reinhard, City Clerk



CITY OF OTTUMWA, IOWA
DOLLAR BID PROPOSAL FOR AUDIT SERVICES



CONTACT: ANDREW GRICE, CPA
andrew.grice@bergankdv.com

bergankDV

EMPOWERING PEOPLE and CREATING A WOW EXPERIENCE FOR OUR CLIENTS.

BERGANKDV, LTD

Andrew Grice, CPA, Partner is entitled to represent BerganKDV, LTD, and empowered to submit a bid and authorized to sign a contract with the City of Ottumwa, Iowa.

**SCHEDULE OF PROFESSIONAL FEES AND EXPENSES
FOR THE AUDIT OF THE 2023-2027 FINANCIAL STATEMENTS**

| | <u>FEE</u> | <u>ACFR PREPERATION FEE</u> | <u>PER SINGLE AUDIT MAJOR PROGRAM FEE</u> |
|------|------------|-------------------------------------|---|
| 2023 | \$42,900 | \$4,000 | \$4,000 |
| 2024 | \$45,000 | \$4,100 | \$4,100 |
| 2025 | \$47,500 | \$4,200 | \$4,200 |
| 2026 | \$50,000 | \$4,300 | \$4,300 |
| 2027 | \$52,500 | \$4,400 | \$4,400 |

THANK YOU.

BERGANKDV.COM | 952.563.6800 | INFO@BERGANKDV.COM





CITY OF OTTUMWA, IOWA PROPOSAL FOR AUDIT SERVICES

bergankDV

CONTACT: ANDREW GRICE, CPA
andrew.grice@bergankdv.com

EMPOWERING PEOPLE and CREATING A WOW EXPERIENCE FOR OUR CLIENTS.

LETTER OF TRANSMITTAL

Waseem A Nisar, Finance Director
City of Ottumwa, Iowa
105 East Third Street
Ottumwa, IA 52501

Dear Mr. Nisar:

On behalf of BerganKDV, I am pleased to submit this proposal for audit services for the City of Ottumwa, Iowa. We appreciate the opportunity to bid these services and your consideration of our firm.

The attached proposal addresses the information you requested, including the unique qualifications of BerganKDV, the depth and breadth of the services we will provide your City and our commitment to providing the highest-quality work through a process that is both efficient and effective.

Our services would include, but not be limited to, the following for year ending June 30, 2023 –June 30, 2027.

1. Performing an audit of the City in accordance with auditing standards generally accepted in the United States of America, *Government Auditing Standards*, and other federal, state, and local requirements, as applicable.
2. Providing an opinion on the City's basic financial statements and an "in-relation to" report on the supporting schedules.
3. Reviewing the City's financial statements and related note disclosures, and supplemental schedules.
4. Reviewing, documenting, and providing recommendations on improving the City's internal control and financial operations.
5. Providing verbal and written guidance on new and ongoing Governmental Accounting Standards Board (GASB) Statements.
6. Meeting with City finance personnel and administration to review the financial statements and a draft of our letter of recommendations for improving the internal control and financial operations of the City.
7. Presenting the financial statements and communications letter to the City Council.
8. Providing copies of the report to the City for the Auditor of State's office, including a searchable pdf of the report, and the communications letter.
9. Being available during the year to provide a wide range of consulting services and answer your questions as they arise.
10. Assistance with depreciation schedules and statistical tables derived from the financial statements.
11. Preparing a draft of the ACFR.

Our Government Market team is located throughout BerganKDV offices. These individuals work only on our governmental entity clients. We have outlined your upper management team in the "Qualifications" section. In addition to these individuals, we will utilize associate level individuals.

We will work with your representatives to schedule specific fieldwork dates to ensure we are meeting your deadlines. The undersigned is a partner and is authorized to make representations for the firm. This proposal is a firm and irrevocable offer for 60 days.

Sincerely,

A handwritten signature in black ink, appearing to read "Andrew Grice". The signature is fluid and cursive, with a prominent initial "A" and a long, sweeping underline.

Andrew Grice, CPA
Partner
BergankDV, LTD
952.563.6800
Andrew.grice@bergankdv.com

TABLE OF CONTENTS

Profile of Firm Proposing:

| | |
|---|---|
| Letter of Transmittal..... | 1 |
| Executive Summary | 4 |
| Who is BergankDV? | 5 |
| Value-Added Services Beyond the Audit | 8 |
| Certifications and Independence | 9 |

Qualifications:

| | |
|-----------------------------|----|
| Client References | 10 |
| Dedicated Service Team..... | 12 |

Scope of Services and Proposed Project Schedule:

| | |
|----------------------------------|----|
| Audit Approach and Timeline..... | 20 |
|----------------------------------|----|

Fees and Compensation:

| | |
|------------|----|
| Fees | 24 |
|------------|----|

Additional Information:

| | |
|------------------|----|
| PlainSight..... | 26 |
| Peer Review..... | 27 |

PROFILE OF FIRM PROPOSING

EXECUTIVE SUMMARY

Thank you for the opportunity to serve as a partner with City of Ottumwa, Iowa. It is our understanding that you are seeking competitive proposals from independent public accounting firms to provide professional financial audit services for year ending June 30, 2023 – June 30, 2027.

Here are a few benefits of working with BerganKDV:

- **A Responsive Firm Who is there for You.** We believe we are your auditors not just at year-end but throughout the year. This means being there for you when issues arise, available when you need us and being responsive to your requests. We demonstrate this through same-day callbacks and in-depth research to get to the heart of your questions. We take a collaborative approach in all our interactions with you.
- **Effective Communication.** BerganKDV has set high internal standards for responding and communicating with our clients. Providing support exactly when and where you need it is the value our team brings. Your time is valuable; we will be clear and efficient in our communications, work to eliminate surprises and meet agreed-upon deadlines. We have a proven track record of performing client's requests based on their preferred timetable and delivering reports to our clients in advance of deadlines.
- **A Personalized Approach to the Audit.** Our audit process includes an annual planning meeting with you to discuss any challenges and changes in the City over the past year, and to build future strategies. We enjoy learning about your City and will work to understand your City from an overall operational standpoint. We are not afraid to "roll up our sleeves" and delve into the details of your operations. This allows us to personalize our audit approach each year, bring best practices, and be a resource for you when it comes to GASB and other reporting standards.
- **Value for Time and Fees Invested.** Receiving value for your fee investment is critical in City government. In addition to offering highly competitive fees, we work diligently to not incur fee surprises. We encourage frequent calls throughout the year, **always at no cost to you.** Our goal is to be your first call when you experience organizational challenges, and our current clients report that this has helped them save time, reduce costs, and build confidence when solving issues.
- **Government Finance Expertise.** Your audit firm needs to understand how municipalities operate and how the environment in which they function is regulated. Your audit firm also needs to understand the intricacies of these entities and how decisions that are made and affect the community. BerganKDV audit professionals are dedicated to your industry beyond the audit; we strive to be your trusted resource in all areas.
- **Innovative thinking and solutions driven.** When working with BerganKDV, clients find that we focus on earning their trust by being actively involved and focused on helping them be successful in all they do. We solve problems. Whether that problem is technology, financial or operations related, we will find a way to help.

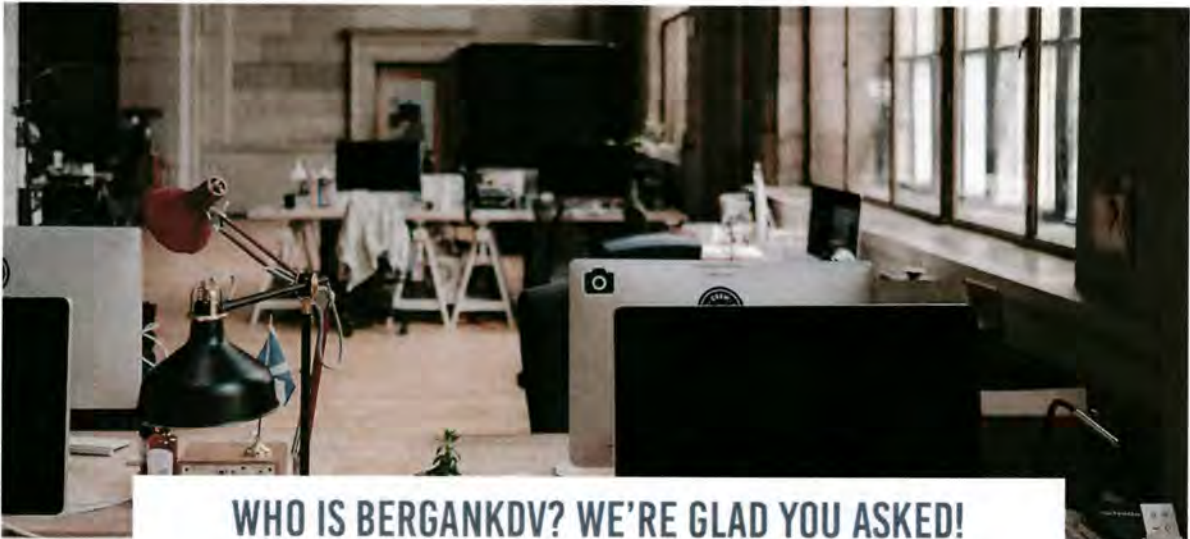

We have an extensive background in working with clients through a strategic approach in all aspects; we do not just keep pace with the trends; we stay ahead of the curve. We explore new ways to reduce costs and operate more efficiently.

THE BACKSTORY

The history of our firm began in 1945, and since the beginning, BerganKDV has been firmly rooted in community. Today we are a Top 100 Firm, we operate in multiple states in nine different offices, employ over 450 experts, and service clients across the country. As we continue to grow, we acknowledge that we are not in the business to provide one-size-fits-all solutions. Every client is different – from business problems to personal preferences. We invest the time to understand your needs and customize our services and solutions to meet them. Our playbook consists of business advisory, tax, assurance and accounting, workforce management, technology, wealth management and turnaround management services. Sure, we offer a robust and competitive service portfolio and notable processes but what really makes us different? **OUR PEOPLE...**

OUR PEOPLE

Relationships are at the core of everything we do, and our products and services are designed to meet the specific needs of our clients. When working with BerganKDV, clients find that we focus on earning their trust by being actively involved and focused on helping them be successful in all they do.

PERSONALIZED SERVICE

Our philosophy is to provide timely, quality services that exceed the expectations of our clients. Outstanding client service requires a successful team effort within our firm and with our clients. Providing outstanding service involves enthusiastic, dependable, and knowledgeable personnel who are responsible for knowing, understanding, and caring about our clients. Our firm believes that outstanding service is a continual process that is refined and enhanced with each client contact.

ENGAGE® | OUR PROVEN VALUE CREATION PROCESS

We have aligned our team around our core values and are driven in our commitment to help clients and team members achieve their potential. We help clients reach their goals by utilizing our value creation process. Results of this process have led to more robust client relationships – deeper trust, enhanced communication, and minimization of time for all. This process is a key component of our strategy in supporting and helping our clients further their organizations.



OUR BUSINESS LINES

BerganKDV has a strong bench of resources and expertise available based on needs of the client. This ensures the most effective and efficient results are delivered!



COMMUNITY SUPPORT

At BerganKDV, we believe in giving back. We support the organizations our people and clients are actively involved with. BerganKDV's culture promotes community involvement by providing employees with paid volunteer time off.

VISION AND VALUES

We are powered by people who do business the Midwest way delivering comprehensive business, financial and technology solutions. Our firm consists of highly talented individuals that put relationships before business deals and clients before profits. Our values drive our decisions.



OUR FOCUS AND OUR PROMISE

We continue to align BerganKDV team member core values and sense of purpose with our firm core values and mission. We hire towards our core values and manage performance through real time feedback corresponding to our core values. We have found that this work results in more open conversations at BerganKDV which impacts employee engagement and client care.

VALUE-ADDED SERVICES BEYOND THE AUDIT

Our goal is to be your first call when you experience organizational challenges. We believe this can occur only when a relationship is developed and nurtured through strong communication and a thorough understanding of your mission, programs, and operations. We are unwavering in our commitment to our clients and make it our mission to ask the right questions, listen actively, understand your expectations, and deliver results. You can expect a partnership with professionals who value trust, integrity, and relationships.

Extensive Governmental Auditing and Consulting Experience

With over *50 years of experience* serving the government community, we have a great appreciation for the unique issues and complexities that you face. We currently work with over 150 governmental entities, including cities, charter schools, school districts, colleges and universities, and other governmental entities, providing a wide array of services including accounting, auditing, and consulting services.

We are dedicated to *keeping informed* of significant developments in the government community and the impact of those developments on our clients. We accomplish this through formal training, including annual seminars, workshops and professional sponsored classes on governmental accounting, auditing, and reporting requirements. We are a member of the Governmental Audit Quality Center of the American Institute of Certified Public Accountants. The Center maintains standards for quality control in governmental audits for CPA firms nationwide.

In addition, many employees of our firm are members and have participated as instructors and speakers at seminars. These presentations have included GASB implementations, auditing standards updates, levy process and related accounting, property taxes and general fund budget, budget issues related to the state budget deficit, accounting and finance policies and procedures and fraud.

Peer Review

Our firm is a member of the Private Companies Section of the AICPA Division for CPA Firms. This Division was founded in 1977 by the AICPA to promote CPA excellence and to provide a voluntary, objective means of monitoring adherence to professional standards. Each member firm is required to periodically subject its audit and accounting practice to a comprehensive quality review by specially trained outside CPAs. Our last such review was just performed recently, and we received a clean report on our practices and methods. A copy of our last peer review report is included on page 27.

CERTIFICATIONS AND INDEPENDENCE

We recognize when we audit a governmental entity, we are required to be familiar with certain rules, regulations, and requirements and, as a firm we are required to meet certain requirements. In that regard, we make the following affirmations:

- Our firm meets the independence requirements relating to the City defined by auditing standards generally accepted in the United States of America and *Government Auditing Standards* issued by the Comptroller General of the United States.
- Our firm and all assigned key professional staff are properly licensed to practice in the State of Iowa.
- Our firm is a member of the American Institute of Certified Public Accountants and the Iowa Society of Certified Public Accountants.
- Our firm has never had a report rejected or classified as substandard by any state or federal agency, or by the Government Finance Officers Association.
- Our firm has never had and currently does not have any pending disciplinary actions or investigations for alleged improper, fraudulent, disreputable, or unfair activities against our firm with state regulatory bodies or professional organizations.
- We accept the professional obligation concerning the American Institute of Certified Public Accountants Interpretation 501-3 "Failure to Follow Standards and/or Procedures or Other Requirements in Governmental Audits."
- Our professional personnel have received adequate continuing education to follow *Government Auditing Standards* and have received adequate continuing professional education over the past two years.
- Our firm is an equal opportunity employer and does not discriminate in employment of persons upon the basis of race, color, creed, national origin, sex, age, or physical handicap, and have an affirmative action plan in place.
- We do not expect any potential audit problems and are not aware of any conflicts of interest about any work performed by the firm for the City.
- We acknowledge and have adequate personnel to comply with the audit schedule provided in the request for proposals.
- Our firm shall maintain during the life of this contract, Professional Liability Insurance, naming and protecting the City against claims for damages resulting from the firm's errors, omissions, or negligent acts. Such policy will contain a limit of liability not less than three million dollars. The insurance will be written by a company duly authorized and licensed to do business in the State of Iowa and will be maintained until all auditing work has been completed and accepted by the City. A certificate of insurance evidencing policies will be furnished to the City and such certificate will specifically indicate that insurance policies shall give the City at least thirty (30) days written notice in the event of cancellation or material change in any of the policies.

QUALIFICATIONS

CLIENT REFERENCES AND EXPERIENCE

A few of our municipality clients serviced are listed below and we encourage you to contact them.

Teresa Fitch
City of Sioux City, IA
912.279.6280
Year Served: 1
Scope of Work: Audit Review of ACFR

Sue Kotchevar
City of Eden Prairie, MN
952.949.8386
Years Served: 3
Scope of Work: Audit and Review of ACFR

Joel Merry
City of Minnetonka, MN
952.939-8254
Years Served: 4
Scope of Work: Audit and Review of ACFR

CLIENT REFERENCES AND EXPERIENCE (CONTINUED)

Over the past year, BergankDV has served as independent auditor or consultant for many Cities as listed below. Audit clients awarded the GFOA Certificate of Excellence in Financial Reporting are identified with an asterisk.

Iowa Cities

Population (0-2,000)

Epworth, IA
North English, IA
Goodell, IA

Population (2,001-5,000)

Cascade, IA
Evansdale, IA
Dyersville, IA - **Mod Acc**

Population (5,001-15,000)

Independence, IA
Knoxville, IA

Population (15,001<)

Coralville, IA - **Mod Acc**
North Liberty, IA
Sioux City, IA* - **Mod Acc**

Minnesota and Nebraska Cities All are on the Modified Accrual Basis

Population (0-2,000)

Bock, MN
Clear Lake, MN
Clearwater, MN
Dundas, MN
Eden Valley, MN
Hilltop, MN
Richmond, MN
Silver Bay, MN
Watkins, MN
Waverly, MN

Population (2,001-5,000)

Ashland, NE
Bennington, NE
Cold Spring, MN
Deephaven, MN*
Elko-New Market, MN
Greenfield, MN
Hanover, MN
Le Seuer, MN
Mora, MN
Rockville, MN
Two Harbors, MN

Population (5,001-15,000)

Baxter, MN*
Big Lake, MN
Corcoran, MN
Dayton, MN
Falcon Heights, MN*
Fergus Falls, MN*
Gretna, NE
Marshall, MN
Mendota Heights, MN
Oak Grove, MN
Osseo, MN
Otsego, MN*
Sauk Rapids, MN
St. Joseph, MN
Wyoming, MN

Population (15,001<)

Albert Lea, MN*
Brooklyn Park, MN*
Cottage Grove, MN*
Crystal, MN*
Eden Prairie, MN*
Faribault, MN*
Forest Lake, MN*
Ham Lake, MN*
Hastings, MN*
La Vista, NE*
Maplewood, MN*
Minnetonka, MN*
New Brighton, MN*
Richfield, MN*
St. Cloud, MN*
Sartell, MN
Woodbury, MN*

DEDICATED SERVICE TEAM

BergankDV has a personalized team of professionals to meet your unique needs. Your BergankDV team has extensive experience working with governmental organizations. This translates into a greater ability to understand your unique organization.



MICHAEL E. DUSCHER, GOVERNMENT CONSULTING LEADER

Minneapolis, Minnesota office

Role and Experience: Mike serves clients in the government sector. He is responsible for growing the client base in the government market by building relationships with potential clients and working with them to help solve pain points they are experiencing in their business operations.

Mike received his bachelor's degree in organizational communication and sociology. He is involved with Northern Voices, a nationally recognized school for deaf and hearing of children and Crescent Cover Respite & Hospice Home for Kids.

On the next couple of pages, we have included the resume for the Partner and Manager that would oversee your engagement. In addition to the individual resumes listed, we will utilize 2 associates on your audit engagement from our GASB team.

DEDICATED SERVICE TEAM (CONTINUED)



NANCY SCHULZETENBERG, CPA, PARTNER

Education: Bachelor of Science in Accounting from Mankato State University, graduated Summa Cum Laude

Experience, Professional and Civic Activities:

- Thirty years of experience in auditing governmental and nonprofit entities
- Member of the Quality Control Committee for our firm
- Appointed by the Commissioner of Education to serve as a member of the Minnesota Department of Education's Advisory Committee on Financial Management, Accounting and Reporting
- Member of the Special Review Committee of the Government Finance Officers Association whose purpose is to review Annual Comprehensive Financial Reports to determine eligibility for the Certificate of Achievement for Excellence in Financial Reporting
- Presenter at the Minnesota Association of School Business Officials Annual Conference, the Central Minnesota Educational Research & Development Council's Annual Conference, the MN Government Finance Officer's Association's Annual Conference, and BerganKDV sponsored seminars
- Instructor at the Minnesota Association of School Business Officials Institute and the Minnesota Association of School Business Officials Certification Program
- Member of Minnesota Society of Certified Public Accountants, American Institute of Certified Public Accountants, Minnesota Association of School Business Officials, and Government Finance Officers Association

Nancy Schulzetenberg CPE FY2021 and FY2022

| Date | Course | Number of CPE Credit hours |
|-------------|--|-------------------------------------|
| 2022 | | |
| 7/26/2021 | Update on Recent AICPA Standard Setting: Staying Current in a Changing Environment | 8.0 |
| 7/27/2021 | 2021 Audit Update | 4.0 |
| 7/27/2021 | Single Audit Walkthrough | 2.0 |
| 10/22/2021 | GFOA GAAFR Review | 1.0 |
| 1/19/2022 | BDO Quarterly Update | 1.0 |
| 4/21/2022 | Auditor Considerations: the FRF Program | 2.0 |
| 6/14/2022 | UGAAP Lunch and Learn | 2.0 |
| 6/15/2022 | Current Issues in Ethics- 2022 | 4.0 |
| 6/29/2022 | Essentials of Audit Sampling | 2.0 |
| 6/29/2022 | A Complete Guide to the Yellow Book | 8.0 |
| 2021 | | |
| 7/15/2020 | Annual School District Update | 1.0 |
| 7/27/2020 | Latest Developments in Nonprofit Accounting and Auditing | 8.0 |
| 7/28/2020 | 2020 Audit Update | 8.0 |
| 7/31/2020 | GFOA GAAFR Review Chapter 1 - Part 1 | 1.0 |
| 8/12/2020 | The 4 Disciplines of Execution; The 5 Disfunctions of a Team | 8.0 |
| 9/9/2020 | 2020 OMB Compliance Supplement | 2.0 |
| 9/25/2020 | GFOA GAAFR Review Chapter 1 - Part 2 | 1.0 |
| 9/30/2020 | CCH ARM - Expertise Made Easy | 1.0 |
| 11/20/2020 | GFOA GAAFR Review Chapter 5 | 1.0 |
| 11/20/2020 | Axcess End User Training | 1.0 |
| 12/2/2020 | Axcess Practice Biller Training | 2.0 |
| 5/3/2021 | Diversity, Equity and Inclusion | 1.0 |
| 5/3/2021 | Yellow Book Update and Practice Issues | 1.0 |
| 5/4/2021 | Independence Update and Practice Issues | 1.0 |
| 5/4/2021 | Single Audit Surprises and Other Matters | 1.0 |
| 5/5/2021 | Professional Ethics Update | 1.5 |
| 5/5/2021 | Results and Outcomes: Igniting and Managing | 1.0 |
| 5/6/2021 | GASB Update and Practice Issues | 1.5 |
| 5/6/2021 | Managing Culture in a Remote Work Environment | 1.5 |
| 5/28/2021 | GFOA GAAFR Review Chapters 10 | 1.0 |
| 6/25/2021 | The 5 Choices To Extraordinary Productivity | 8.0 |

DEDICATED SERVICE TEAM (CONTINUED)



ANDREW GRICE, CPA, PARTNER

Education: Bachelor of Science in accounting from St. Cloud State University, graduated Cum Laude

Experience, Professional and Civic Activities: Professional and Civic Activities:

- Fourteen years of experience with financial reporting in accordance with GAAP, ACFR requirements, analysis of internal control, performing audits of financial statements and single audits in accordance with OMB Circulars and Uniform Guidance.
- Responsible for the planning, fieldwork and reports for numerous audits of cities, school districts, charter schools, and other government entities.
- Attends continuing education, workshops and conferences on city and school district accounting and reporting requirements on an annual basis that qualifies as “yellow book” continuing professional education and on governmental and single audit accounting, auditing and reporting
- Extensive use of computer and software applications to assist in the preparation and performance of the audit process.
- Presents audit reports, financial statements, and communications letters to management, school boards and city councils.
- Instructor for the Minnesota Municipal Clerks Institute Fund Accounting and Budgeting course.
- Instructor for the Government Finance Officers Association Intermediate Governmental Accounting course.
- Develops internal training for BerganKDV government auditors.
- Certified Public Accountant, licensed to practice in the State of Minnesota
- Minnesota Society of Certified Public Accountants
- American Society of Certified Public Accountants
- Minnesota Association of School Business Officials
- Government Finance Officers Association

Andrew Grice CPE FY2021 and FY2022

| Date | Course | Number of CPE Credit hours |
|-------------|--|-------------------------------|
| 2022 | | |
| 7/26/2021 | Update on Recent AICPA Standard Setting: Staying Current in a Changing Environment | 8.0 |
| 7/27/2021 | 2021 Audit Update | 4.0 |
| 8/16/2021 | Leadership Development: Leading Change Part 1 | 4.0 |
| 8/23/2021 | Leadership Development: Leading Change Part 2 | 4.0 |
| 10/22/2021 | GFOA GAAFR Review | 1.0 |
| 1/28/2022 | GFOA GAAFR Review | 1.0 |
| 2/25/2022 | GFOA GAAFR Review | 1.0 |
| 3/30/2022 | Annual Comprehensive Financial Report Review Session | 3.0 |
| 4/21/2022 | Working Remotely | 2.0 |
| 6/14/2022 | UGAAP Lunch and Learn | 2.0 |
| 6/15/2022 | Current Issues in Ethics- 2022 | 4.0 |
| 2021 | | |
| 7/15/2020 | Annual School District Update, GASB 84 | 3.0 |
| 7/27/2020 | Latest Developments in Nonprofit Accounting and Auditing | 8.0 |
| 7/28/2020 | 2020 Audit Update | 8.0 |
| 7/31/2020 | GFOA GAAFR Review Chapter 1 - Part 1 | 1.0 |
| 8/10/2020 | Leadership Development | 8.0 |
| 8/27/2020 | Yellow Book and Single Audit Update | 4.0 |
| 10/30/2020 | GFOA GAAFR Review Chapter 4 | 1.0 |
| 11/20/2020 | GFOA GAAFR Review Chapter 5 | 1.0 |
| 11/30/2020 | Axcess End User Training | 1.0 |
| 12/3/2020 | Axcess Practice Biller Training | 2.0 |
| 12/18/2020 | GFOA GAAFR Review Chapter 7 | 1.0 |
| 1/5/2021 | Languages of Appreciation | 1.0 |
| 1/6/2021 | Onboarding & Ongoing Training | 1.0 |
| 1/21/2021 | Charter School 990 Preparation | 2.0 |
| 1/22/2021 | Charter School 990 Preparation | 5.0 |
| 1/29/2021 | GFOA GAAFR Review Chapter 6 | 1.0 |
| 2/26/2021 | GFOA GAAFR Review Chapter 8 | 1.0 |
| 3/17/2021 | Annual Comprehensive Financial Report Review Session | 2.0 |
| 3/26/2021 | GFOA GAAFR Review Chapters 8 and 9 Part 1 | 1.0 |
| 4/19/2021 | COVID Issues affecting CPAs | 2.0 |
| 4/30/2021 | GFOA GAAFR Review Chapter 9 Part 2 | 1.0 |
| 6/3/2021 | 2021 Ethics Seminar | 4.0 |

DEDICATED SERVICE TEAM (CONTINUED)



DUSTIN OPATZ, CPA, AUDIT MANAGER

Des Moines, Iowa office

Education: Bachelor of Science in Accounting from St. Cloud State University

Audits 15-20 Cities(6 ACFRs) annually, including 10 Iowa Cities

Is independent to the Engagement as defined by Government Auditing Standards

Experience, Professional and Civic Activities:

- Eight+ years of experience with financial reporting in accordance with GAAP, ACFR requirements, analysis of internal control, performing audits of financial statements and single audits in accordance with OMB Circulars and Uniform Guidance
- Responsible for the planning, fieldwork and reports for numerous audits of cities, school districts, charter schools, and other government entities
- Attends continuing education, workshops and conferences on city and school district accounting and reporting requirements on an annual basis that qualifies as "yellow book" continuing professional education
- Attends workshops on governmental and single audit accounting, auditing and reporting on an annual basis
- Financial statement and communication letter preparation
- Extensive use of computer and software applications to assist in the preparation and performance of the audit process
- Certified Public Accountant, licensed to practice in the State of Iowa
- Presenter at the Government Finance Officers Association Annual ACFR Review, and BerganKDV sponsored seminars
- Professional and Civic Activities
- Iowa Society of Certified Public Accountants
- American Institute of Certified Public Accountants
- Minnesota Government Finance Officers Association
- Minnesota Association of School Business Officials
- Iowa Association of School Business Officials

| Dustin Opatz CPE FY2021 and FY2022 | | |
|---|--|-----------------------------------|
| Date | Course | Number of CPE Credit hours |
| 2022 | | |
| 7/26/2021 | Update on Recent AICPA Standard Setting: Staying Current in a Changing Environment | 8.0 |
| 7/27/2021 | 2021 Audit Update | 4.0 |
| 7/28/2021 | DiSC & Application Training | 5.0 |
| 8/27/2021 | GFOA GAAFR Review Chapter 6 | 1.0 |
| 9/24/2021 | GFOA GAAFR Review Chapter 14 | 1.0 |
| 12/7/2021 | Charter School 990 Preparation | 6.0 |
| 3/30/2022 | Annual Comprehensive Financial Report Review Session | 3.0 |
| 5/25/2022 | IDEA Data Analysis Level 1 | 16.0 |
| 6/15/2022 | Current Issues in Ethics- 2022 | 4.0 |
| 2021 | | |
| 7/27/2020 | Latest Developments in Nonprofit Accounting and Auditing | 8.0 |
| 7/28/2020 | 2020 Audit Update | 8.0 |
| 8/28/2020 | GFOA GAAFR Review Chapter 1 - Part 1 | 1.0 |
| 9/25/2020 | GFOA GAAFR Review Chapter 1 - Part 2 | 1.0 |
| 10/30/2020 | GFOA GAAFR Review Chapter 4 | 1.0 |
| 11/20/2020 | GFOA GAAFR Review Chapter 5 | 1.0 |
| 1/21/2021 | Charter School 990 Preparation | 2.5 |
| 1/29/2021 | GFOA GAAFR Review Chapter 6- Part 1 | 1.0 |
| 2/21/2021 | GFOA GAAFR Review Chapter 6- Part 2 | 1.0 |
| 3/17/2021 | Annual Comprehensive Financial Report Review Session | 2.0 |
| 3/26/2021 | GFOA GAAFR Review Chapters 8 and 9 | 1.0 |
| 5/3/2021 | Excel Treasure Maps | 1.0 |
| 5/3/2021 | Yellow Book Update and Practice Issues | 1.0 |
| 5/4/2021 | Independence Update and Practice Issues | 1.0 |
| 5/4/2021 | Single Audit Surprises and Other Matters | 1.0 |
| 5/4/2021 | Employee Motivation and Engagement in New World of Work | 1.0 |
| 5/5/2021 | Professional Ethics Update | 1.5 |
| 5/5/2021 | Igniting and Managing High Performance in Remote Environment | 1.0 |
| 5/6/2021 | Delegate Excellence - Keys to Grow and Capitalize on your Team Resources | 1.5 |
| 5/28/2021 | GFOA GAAFR Review Chapters 10 | 1.0 |
| 6/3/2021 | 2021 Ethics Seminar | 4.0 |

DEDICATED SERVICE TEAM (CONTINUED)

Office Performing Audit

Our Government Market team is located throughout BergankDV offices. These individuals work only on our governmental entity clients. We have outlined your upper management team in the "Qualifications" section. Our team consists of 3 audit partners, 5 audit directors/managers, 1 director of consulting, 5 senior/supervisor and 8 associate level members, all that focus on governmental entities. In addition, we have another partner, 2 directors, 2 seniors and 5 associate level members that all have experience working on governmental audits. In addition to individual resumes listed on pages 12-18, we will utilize 2 associate level members on your audit engagement. The Manager assigned to your engagement is located in our Des Moines, Iowa office. All partners, Directors/Managers and Supervisors are licensed CPAs.

Commitment to Staff Continuity and Training

To keep continuity and efficiencies high, we believe that consistent team members are advantageous for both our firm and your organization. We pride ourselves on maintaining the right balance of continuity on each of our engagements to ensure a "fresh" look at the annual audit process. Rotation of senior level staff only occurs after the merits of such rotation have been discussed and approved by your organization.

Independence

Our firm has no conflict of interest regarding any other work performed by our firm for your organization. Our firm meets the independence requirements relating to your organization as defined by auditing standards generally accepted in the United States of America. We annually review independence related to all our client relationships as part of our internal control compliance process.



AUDIT APPROACH AND TIMELINE

OUR GOAL FOR YOU IS TO CREATE VALUE AND TO MINIMIZE SURPRISES. We do this through a specific, well planned audit. What makes BerganKDV unique from other firms is that we continually improve our audit process beyond what is expected by our profession. A few of the BerganKDV advantages:

- **Collaborative Audit Process.** We see the audit process as a joint effort with you and BerganKDV. We want to work together to make it as painless as possible.
- **A comprehensive view of the City's financial health.** Through our extensive government experiences, we understand a City's health is not only about the finances. The vision, mission and programming provide the blueprint for the City's direction. We review this information in relation to the financial statements and provide our observations based on a comprehensive view of the City's health.
- **Technology resource on internal controls.** Technology experts from the BerganKDV Technology Group can assist in evaluating your technology controls. Their expert advice has proven to be a valuable resource as they answer technical questions and offer specific recommendations.
- **Review of the work papers during fieldwork.** We complete most of our work in the field and provide a comprehensive exit conference. The exit conference includes a review of the draft financial statement numbers, any internal control, compliance, and state statute findings.
- **Supervisors, managers and partners on-site.** The involvement of our supervisors, managers and partners in the field is essential to being a trusted partner and delivering an exceptional client experience. We believe it is important to be on-site and available to answer questions. This also allows our managers and partners to review documentation throughout the process.
- **Meeting communications.** Our presentations are designed to capture information that is useful and meaningful. Our presentations are focused on audit results, trends, and other information relevant to your City and related entities, not details of the financial statement amounts.

Beyond Expectations

BerganKDV takes a four-phased audit approach that gets results by:

- Leveraging what is working well.
- Focusing on pre audit planning, collaboration, and communication.
- Staying accountable to a schedule.
- Meeting with you and your team to ensure every detail has been finalized and the audit is complete.
- Exchanging information regarding our performance, opportunities to enhance experiences and future strategic opportunities.

AUDIT APPROACH AND TIMELINE (CONTINUED)

Our audits are designed to focus our energy and our audit tests on the areas of your operations that contain the most risk. This equates to a better product for the City.

PHASE ONE – INITIAL PLANNING AND PROGRAM DEVELOPMENT (JULY FOLLOWING THE FISCAL YEAR END)

Our main objective is to get to know the City as a resident or employee would. We want to understand not only your finances, but also your operational goals and objectives. What makes your City unique? How can that knowledge help us perform the best audit possible? When those questions are answered, we know we achieved our goal for Phase One.

During this phase, we gather the information we need to create an effective audit program and make preliminary judgments of materiality. Highlights include:

- Reviewing your internal control documents and interviewing your key employees and representatives to gain operational information.
- Discussing your goals, objectives, and the current challenges facing your operations; those are then shared across your BerganKDV team and incorporated into our audit plan.
- Obtaining population sizes ranging from 25-60 for certain transactions-based finance systems and selecting which transactions we will test for internal control and compliance testing. Selections will be based on our data analysis results, analyzing transactions on a risk-based level.
- Obtaining your current financial reports and budgets and perform overall analytical review procedures.
- Obtaining applicable City organizational charts, policies, bond documents, leases, and other legal contracts.
- Reviewing with your staff our audit documentation requests. **We audit and request information that is used internally by your staff to manage operations, we do not require specific templates to be used.**

We will work with the management team to determine the preferred means of communication, whether phone or email. In addition, we utilize Suralink, a workflow management software that improves efficiency by streamlining our audit request process. The simple interface includes team assignments and deadlines, so there are no misunderstandings on expectations.

Our audit process incorporates automated audit tools (Knowledge Coach) and work papers to provide our clients with timely information and effective and efficient audits. In addition, we use CCH's TeamMate Analytics, an Excel add-on used to extract and analyze data quickly and efficiently. We also subscribe to various benchmarking and data analysis providers.

Your Expected Role: Provide BerganKDV with policies, internal control documents and a preliminary trial balance; provide contact information for all council members and staff so we may set up appointments/interviews with selected representatives; begin to gather documentation for fieldwork.

AUDIT APPROACH AND TIMELINE (CONTINUED)

PHASE TWO – AUDIT PROGRAM EXECUTION (BEGINNING/MIDDLE OF JANUARY FOLLOWING THE FISCAL YEAR END)

Project execution is performing the procedures outlined in your audit plan as developed in Phase One. Our audit procedures will include examining, on a test basis, evidence supporting the amounts and disclosures in the financial statements. We will discuss potential ideas and best practices with your personnel relating to our recommendations for improving internal control, procedures and compliance with laws and regulations. Any issues identified, proposed audit adjustments, or other recommendations will be discussed with management throughout the execution of our audit procedures. We perform test work with as little disruption as possible to City staff's regular duties.

Highlights of this phase include:

- Auditing year-end account balances, testing internal control, assessing compliance to determine if your systems and controls are functioning as designed.
- Using sampling techniques to test areas including transactions, internal controls and legal compliance using the scope mandated by the Auditor of State's Office. Sample sizes range from 25-60 based on our risk assessment.
- Using IDEAS data mining software, we look for trends and anomalies in your payroll, vendor payment, and cash receipts process.

Your Expected Role: Be available to answer questions during scheduled audit fieldwork, provide audit workpapers or reconciliations with documentation that is reasonable and reviewed during Phase One.

PHASE THREE – POST-AUDIT CRITIQUE AND EXIT CONFERENCE (EARLY FEBRUARY FOLLOWING THE FISCAL YEAR END)

This phase of the audit includes reviewing all the components of the financial statements and prepare the communications letter and relevant financial trend data for the Council presentation. Finally, opinions on the financial statements, Government Auditing Standards and Single Audit, if required, will be prepared.

We will then present this information to management allowing you time to review the financial statement reporting package including the draft financial statements and any internal control findings or recommendations that arise during the audit. This phase allows you time to assess, discuss and develop a corrective action plan, if needed.

Your Expected Role: Review preliminary financial statements and reports to provide BergankDV with input and feedback.

AUDIT APPROACH AND TIMELINE (CONTINUED)

PHASE FOUR – PRESENTATION OF AUDIT REPORT (FEBRUARY FOLLOWING THE FISCAL YEAR END)

The final phase of the process is the presentation of the reports to the City Council. The presentation provides the governing body with information about the year's financial activity compared to past trends and expected results. We also provide other relevant and interesting observations relating to your financial statistics that will help provide the governing board with a deeper understanding of your operations. We understand all organizations have individual needs and we look forward to getting your feedback on graphs and statistics.

Professional standards require that we provide you with information regarding the auditor's responsibility under generally accepted auditing standards, significant accounting policies, accounting estimates and management judgments, significant audit adjustments, other information in documents containing audited financial statements, disagreements with management, consultation with other auditors, major issues discussed with management prior to retention as auditors and difficulties encountered in performing the audit. We will provide this information in written form via the communications letter and will discuss with administration during the review of the preliminary audit report.

Your Expected Role: Provide BergankDV with information and feedback for presentation preferences.

FEES

Our fees for the services are based on the amount of time and the level of experience of the individuals who perform the services. In addition, we assume that the City's accounting personnel will provide the appropriate workpapers, documents, schedules, and clerical assistance, we will not encounter any significant or unusual circumstances which will affect the scope of our engagement, and no significant changes to the City's operations will occur. However, if situations arise which affect the scope of the engagement, we will discuss them with you prior to incurring the additional cost. **At no time will we bill the City for extra time or charges unless we have verbal communication regarding the issues, your options, and an agreement for additional fees.**

Following is a description of the services we will provide under this agreement for the years ended June 30, 2023 – June 30, 2027:

1. Performing an audit of the City in accordance with auditing standards generally accepted in the United States of America, *Government Auditing Standards*, and other federal, state, and local requirements, as applicable.
2. Providing an opinion on the City's basic financial statements and an "in-relation to" report on the supporting schedules.
3. Reviewing the City's financial statements and related note disclosures, and supplemental schedules.
4. Reviewing, documenting, and providing recommendations on improving the City's internal control and financial operations.
5. Providing verbal and written guidance on new and ongoing Governmental Accounting Standards Board (GASB) Statements.
6. Meeting with City's finance personnel and administration to review the financial statements and a draft of our letter of recommendations for improving the internal control and financial operations of the City.
7. Presenting the financial statements and communications letter to the City Council.
8. Providing bound copies of the report to the City for the Auditor of State's Office, including a searchable pdf of the report, and the communications letter.
9. Being available during the year to provide a wide range of consulting services and answer your questions as they arise.
10. Assistance with depreciation schedules and statistical tables derived from the financial statements.
11. Preparing a draft of the ACFR.

FEES (CONTINUED)

Billing and Collection Expectations

Our fees are due as services progress and are generally billed at the completion of each phase of the audit. These invoices are payable on presentation. Invoices are delinquent if not paid within 60 days.

Off-season Communication

We encourage questions throughout the year and ask our clients to submit to us their monthly financial statements and board of director minutes, so we can stay abreast of their operations, and identify/resolve any issues prior to year-end. We will not invoice additional amounts unless substantial research or work is required, in which case, we will discuss the scope of any additional work and proceed only after we have reached a mutually agreeable fee arrangement.

Out of Scope Professional Services

We do not surprise bill. If during our engagement you request additional services which require more than a minimum amount of time, we will provide an engagement letter with the fees and services specified, only after we have verbal communication and agreement. Additional special projects and consulting requested during the year will be billed at an hourly rate commensurate with the level of experience required.



With BerganKDV's PlainSight, you can empower your employees to speak up when they witness fraudulent activity through an easily accessible and completely anonymous hotline system. Based on the tip criteria, our certified team of fraud professionals is available to investigate and report back with next steps if fraudulent evidence is discovered.

One year subscription complimentary for first year audit engagements

A TIP COULD BE ALL IT TAKES

You can rest assured as a business leader that your employees are equipped with a powerful and safe tool to protect your company against those who wish to harm it.

OUR PROMISE TO YOU

We will work directly with you to establish an implementation and use strategy that fits your needs and coordinate with you when tips become viable signs of potential fraudulent activity. Safety and anonymity are our main priority for your business. Our goal is to highly encourage hotline usage and promote the idea that no tip is too small to make a difference.

It is estimated that organizations lose 5% of revenue each year due to fraud with average losses being around \$1.5 million. **Don't foot the bill to fraudsters.**

MORE THAN A PHONE LINE

WHAT OTHER SERVICES ARE INCLUDED WHEN YOU UTILIZE PLAINSIGHT FOR YOUR FRAUD DETECTING NEEDS?

- Easy to use web submission tool
- Communication packages to educate and inform your employees
- On-demand employee training for how to use and signs of fraud
- Admin level access to review items and communicate with our Forensic team

Let our team of experts grant you peace of mind and educate your employees to make the call today that may save you tomorrow.



FIND YOUR PEACE OF MIND

bergankdv.com | connect@bergankdv.com | #starthere

bergankdv

PEER REVIEW



Report on the Firm's System of Quality Control

March 12, 2021

To the Partners of BerganKDV, LLC
and the Peer Review Committee of the Minnesota Society of CPAs.

We have reviewed the system of quality control for the accounting and auditing practice of BerganKDV, LLC (the firm) in effect for the year ended March 31, 2020. Our peer review was conducted in accordance with the Standards for Performing and Reporting on Peer Reviews established by the Peer Review Board of the American Institute of Certified Public Accountants (Standards).

A summary of the nature, objectives, scope, limitation of, and the procedures performed in a System Review as described in the Standards may be found at www.aicpa.org/prsummary. The summary also includes an explanation of how engagements identified as not performed or reported in conformity with applicable professional standards, if any, are evaluated by a peer reviewer to determine a peer review rating.

Firm's Responsibility

The firm is responsible for designing a system of quality control and complying with it to provide the firm with reasonable assurance of performing and reporting in conformity with applicable professional standards in all material respects. The firm is also responsible for evaluating actions to promptly remediate engagements deemed as not performed or reported in conformity with professional standards, when appropriate, and for remediating weaknesses in its system of quality control, if any.

Peer Reviewer's Responsibility

Our responsibility is to express an opinion on the design of the system of quality control and the firm's compliance therewith based on our review.

Required Selections and Considerations

Engagements selected for review included an engagement performed under *Government Auditing Standards*, including compliance under the Single Audit Act, and audits of employee benefit plans.

As a part of our peer review, we considered reviews by regulatory entities as communicated by the firm, if applicable, in determining the nature and extent of our procedures.

PEER REVIEW [CONTINUED]

The Partners of BergankDV, LLC
and the Peer Review Committee of the Minnesota Society of CPAs
Page Two

Opinion

In our opinion, the system of quality control for the accounting and auditing practice of BergankDV, LLC in effect for the year ended March 31, 2020, has been suitably designed and complied with to provide the firm with reasonable assurance of performing and reporting in conformity with applicable professional standards in all material respects. Firms can receive a rating of *pass*, *pass with deficiency (ies)*, or *fail*. BergankDV, LLC has received a peer review rating of *pass*.

Certified Public Accountants

Little Rock, Arkansas

THANK YOU.

BERGANKDV.COM | 952.563.6800 | INFO@BERGANKDV.COM



EMPOWERING PEOPLE and CREATING A WOW EXPERIENCE FOR OUR CLIENTS.

Contact Us

- 📞 641.683.0600
- ✉️ humanrights@ottumwa.us

Meetings

2nd Monday of Each Month
City Hall Ottumwa, IA
5:30 PM



Human Rights Commission

Re-Established June 2022

What We Do

Purpose

The purpose is to increase awareness, understanding and appreciation of diversity, equity and inclusion within the community; and to proclaim a public policy of nondiscrimination by securing freedom from discriminatory practices based on a person's race, creed, color, sex, sexual orientation, gender identity, national origin, religion, or disability as defined in I.C.A. ch. 216 ("Protected Groups"), protecting individual dignity, ensuring their full productive capacities, preserving the public safety, health, and general welfare, and promoting the interests, rights, and privileges of individual citizens within the city.

Duties

- Connect and listen to community concerns
- Connect with citizens with the Iowa Civil Rights Commission when needed
- Recommend policies and programs to implement human rights goals in the community.
- Provide educational opportunities to the community
- Collect and report data and report it on a biannual basis
- Promote human rights
- Celebrate diversity

Who We Are



Amy Norris Hernandez
Nathan Wilson
Dr. Peter Reiter
John Fenner, Chair
Sandra Wirfs

Gaylon Davis
Jacquelyn Pope
Marlena Wolfing
Connie Johnson

Introduction:

As members of the Ottumwa Human Rights Commission, we have become increasingly concerned about what we perceive to be a growing wave of intolerance throughout the United States. Rhetoric of exclusion and bigotry aimed at various groups has become more common and seemingly acceptable in both public and political speech. Numerous states, including Iowa, have passed laws restricting the rights of some minority groups. School curricula have been altered to force the teaching of a sanitized version of our nation's history. Books, even classics, are being banned in schools. We believe that these trends and actions are both regrettable and alarming. Therefore, our Commission has drafted the following statement in order to state our commitment to the human rights of all people in our community.

Statement:

Among the goals of the Ottumwa Human Rights Commission, as stated in the establishing Ordinance, are to increase awareness, understanding and appreciation of diversity within the community; to proclaim a public policy of nondiscrimination; and to protect individual dignity.

We understand that we live in a pluralistic society. We accept, value and celebrate both the shared humanity and differences visitors and residents bring to our city. While honoring this common humanity, we will oppose all efforts to marginalize, disparage, harm or make unwelcome any individual or group due to their race, creed, religion, color, sex, sexual orientation, gender identity, national origin, socioeconomic status or disability.

The Ottumwa Human Rights Commission is devoted to creating an environment that fosters advocacy and a mutual respect for all individuals in Ottumwa. In so doing, we unequivocally reject all forms of intolerance and marginalization.

Introduction:

As members of the Ottumwa Human Rights Commission, we have become increasingly concerned about what we perceive to be a growing wave of intolerance throughout the United States. Rhetoric of exclusion and bigotry aimed at various groups has become more common and seemingly acceptable in both public and political speech. Numerous states, including Iowa, have passed laws restricting the rights of some minority groups. School curricula have been altered to force the teaching of a sanitized version of our nation's history. Books, even classics, are being banned in schools. We believe that these trends and actions are both regrettable and alarming. Therefore, our Commission has drafted the following statement in order to state our commitment to the human rights of all people in our community.

Statement:

Among the goals of the Ottumwa Human Rights Commission, as stated in the establishing Ordinance, are to increase awareness, understanding and appreciation of diversity within the community; to proclaim a public policy of nondiscrimination; and to protect individual dignity.

We understand that we live in a pluralistic society. We accept, value and celebrate both the shared humanity and differences visitors and residents bring to our city. While honoring this common humanity, we will oppose all efforts to marginalize, disparage, harm or make unwelcome any individual or group due to their race, creed, religion, color, sex, sexual orientation, gender identity, national origin, socioeconomic status or disability.

The Ottumwa Human Rights Commission is devoted to creating an environment that fosters advocacy and a mutual respect for all individuals in Ottumwa. In so doing, we unequivocally reject all forms of intolerance and marginalization.